

Indiana Weatherization Field Guide

SWS Edition



ihcda

Indiana Housing &
Community Development
Authority



SATURN RESOURCE MANAGEMENT

Serving the building performance industry since 1980

1.800.735.0577 • SRMI.BIZ

Indiana Weatherization Field Guide SWS-Aligned Edition

Primary author: John Krigger

**Illustrators: John Krigger, Bob Starkey,
Steve Hogan, Wayne Harney, Darrel Tenter**

Technical publisher: Darrel Tenter

Editors: Darrel Tenter

***The Indiana Weatherization Field Guide* describes procedures used to analyze and improve the performance of existing homes retrofitted under the Department of Energy's Weatherization Assistance Program. This field guide is cross referenced to DOE's Standard Work Specifications for Home Energy Upgrades.**

The author recognizes the knowledge, ingenuity, and creativity of the weatherization network throughout the United States for pioneering, changing, and perfecting the standards, specifications and procedures documented in this field guide.

INCAA Reviewers:

**Christin Willman, Fred Clade, Michael Hastings, Justin
Ackeret**

IHCDA Reviewers:

Emily Krauser, Carlos Bogue

Copyright 2018 by

Saturn Resource Management, Inc.

Version: 040918

Acknowledgments

We are Saturn Resource Management of Helena Montana. Our content expertise is energy conservation for buildings. We publish documents, create curricula, implement training, and consult.

We thank the Department of Energy's Weatherization Assistance Program (WAP) for promoting residential energy efficiency for more than 35 years. Without the DOE, our industry wouldn't exist as a building-science-based endeavor.

Weatherization agencies, State WAP grantees, private contractors, national laboratories, utility companies, and non-profit corporations have also contributed much to the content in this guide.

For many years, we've tried to list the specific people who have influenced Saturn's work in a substantial way. Now there are just too many contributors to list. You know who you are: thank you.

WAP energy specialists and energy experts associated with WAP are our most important contributors. Saturn's present and past staff have done an excellent job of compiling and presenting the information in this field guide.

Thanks to everyone who has reviewed this field guide and labored to improve it. Thank you, past-and-present customers, for allowing Saturn the privilege of serving you. We appreciate your business.

Preface

This Weatherization Field Guide outlines a set of best practices for the Weatherization Assistance Program (WAP). Weatherization experts collaborating with the National Renewable Energy Lab (NREL) developed the Standard Work Specifications (SWS) beginning in 2009. The new SWS standards reside online in www.sws.nrel.gov.

The SWS presents details and outcomes for weatherization measures that are required when a weatherization agency selects a weatherization measure, based on its cost effectiveness. The technical content of this guide aligns with the SWS requirements.

A major purpose of this guide is to show how its contents are aligned with the SWS. Therefore, we've inserted hypertext references to the specific SWS details that our content aligns to. When you click on one of these references, the relevant detail appears in your browser.

This guide also incorporates information from the following standards and specifications.

- DOE Weatherization Job Task Analysis (most current)
- Building Performance Institute's (BPI) relevant standards
- International Residential Code
- International Energy Conservation Code
- Standards for combustion systems by The National Fire Protection Association (NFPA) , including NFPA 54, 31, and 211.

This guide with health and safety, an important topic for both workers and clients. The first part of the chapter discusses client health and safety. The last part of the chapter covers worker health and safety.

Next, the guide presents a chapter on energy auditing, inspecting, client relations, and work flow development. The following chapter discusses insulation and air sealing materials and their characteristics. We follow that with four chapters on the four distinct parts of the building shell: attics and roofs; walls; floors and foundations; and windows and doors.

The guide's largest chapter is heating and cooling. We created a separate chapter on ventilation, which includes whole-house ventilation, local ventilation, attic and crawl-space ventilation, and ventilation for cooling.

We've included a dedicated chapter on mobile homes where we discuss the ECMs particular to mobile homes. In this chapter we often refer to other sections of the guide that contain information that's relevant to both mobile homes and site-built homes.

The last chapter's topic, Air Leakage Diagnosis, is an effective tool for weatherization agencies to guide cost-effective air sealing. This chapter doesn't align to the SWS because the SWS doesn't detail testing procedures.

Like the SWS, this field guide is a living document and a work-in-progress. The field guide will change as the SWS changes. We hope you find this guide authoritative, easy to use, and well aligned to the SWS. We welcome all comments, suggestions and criticism. Thanks for your hard work and dedication in implementing the Weatherization Assistance Program.

John Krigger
jkrigger@srmi.biz

TABLE OF CONTENTS

1: Health and Safety

Educate Occupants and Building Operators	20
Fire Safety.....	20
Carbon Monoxide (CO)	21
Causes of Carbon Monoxide (CO)	22
Smoke and Carbon Monoxide (CO) Alarms	23
Occupant Education about Alarms.....	23
Smoke Alarms.....	24
CO Alarms.....	24
Gas Range and Oven Safety	25
Reducing Moisture Problems	28
Moisture Sources and Effects	28
Moisture Reduction Strategies	28
Symptoms of Moisture Problems.....	29
Solutions for Moisture Problems	30
Crawl Space Moisture and Safety Issues	31
Ground Moisture Source-Reduction.....	32
Pollutants Source Control.....	33
Radon.....	33
Asbestos Containing Materials (ACM)	34
Lead-Safe Procedures	35
Electrical Safety.....	36
Decommissioning Knob-and-Tube Wiring.....	37
Constructing Shielding for Knob-and-Tube Wiring.....	37
Worker Health and Safety.....	39
Commitment to Safety	39
New Weatherization Professionals.....	39
Driving.....	40
Lifting and Back Injuries	40
Respiratory Health.....	40

Hazardous Materials	41
Falls	41
Tool Safety	41
Safety for Crawl Spaces and Other Confined Areas	41
Safety for Extreme Weather	42
SWS Alignment	42

2: Energy Audits and Quality Control Inspections

Purposes of an Energy Audit	43
Energy-Auditing Judgment and Ethics	44
Energy-Auditing Recordkeeping	44
Communication Best Practices	45
Client Interview	45
Deferral of Weatherization Services	46
Parts of an Energy Audit	47
Visual Inspection	48
Diagnostic Testing	48
Work Scope Development	49
Work Orders	50
Quality Control Inspections	51
In-Progress Inspections	51
Quality Control Inspection	51
Grantee (IHCDA) Monitoring of Subgrantees	54
DOE Monitoring of Grantees (States)	54
Understanding Energy Usage	55
Baseload Versus Seasonal Use	55
Energy Indexes	58

Client Education.....	59
SWS Alignment.....	59

3: Weatherization Materials

Air-Sealing Goals	60
Air Sealing Safety.....	61
Air Sealing and Fire Containment	61
Air Sealing Materials	62
Air-Barrier Materials	62
Backing Materials.....	63
Caulking and Adhesives	64
Polyurethane Foam Air Sealant	66
Insulation Building Science	68
Insulation Certificate.....	68
Insulation Material Characteristics.....	69
Fibrous Insulation Materials.....	69
Operating the Insulation Blowing Machines	73
Spray Foam Insulation Materials	74
Special Safety Precautions for Spray Foam.....	76
Fire Protection for Foam Insulation.....	77
Foam Board Insulation.....	78
Insulation Durability	80
SWS Alignment.....	81

4: Attics and Roofs

Air-Sealing Attics and Roofs.....	82
Sealing Vertical Chases	82
Air Sealing Recessed Lights	85
Sealing Porch Roof Structures.....	88

Sealing Joist Cavities Under Knee Walls	89
Sealing Kitchen or Bathroom Interior Soffits	89
Sealing Two-Level Attics	90
Sealing Dropped Ceilings	90
Insulating Attics and Roofs	93
Preparing for Attic Insulation	93
Safety Preparations for Attic Insulation	95
Blowing Attic Insulation	96
Closed-Cavity Attic Floors	98
Insulating Closed Roof Cavities	99
Exterior Rooftop Foam Insulation	101
Installing Fiberglass Batts in Attics	101
Roof Deck Underside /Cathedralized Attics	102
Vaulted Attics	103
Finished Knee-Wall Attics	104
Knee-Wall Insulation	107
Access Doors in Vertical Walls	109
Walk-Up Stairways and Doors	111
Insulating & Sealing Pull-Down Attic Stairways	111
Parapet Walls	112
Skylights	113
Whole-House Fans	113
SWS Alignment	113

5: Walls

Air Sealing Walls	114
Multifamily Firewalls	115
Built-In Cabinets/Shelves	116
Wall Framing Around Fireplaces and Chimneys	116
Cooling Appliances Installed through Walls or Windows	117
Balloon Framed Walls	119
Minor Air Sealing	120
Window and Door Frames	120

Rim Joist Area	121
Masonry Surfaces.....	121
Interior Wall Top Plates	121
Wall Insulation	122
Wall Insulation: Preparation and Follow-up.....	123
Retrofit Closed-Cavity Wall Insulation	125
Open-Cavity Wall Insulation	128
Insulated Wall Sheathing	132
Insulating Unreinforced Brick Walls	133
SWS Alignment.....	133

6: Floors and Foundations

Thermal-Boundary Decisions: Floor or Foundation.....	134
Air Sealing Foundations and Floors.....	136
Garages Underneath Living Areas.....	136
Plumbing Penetrations	137
Stairways to Unconditioned Areas	138
Incomplete Finished Basements	141
Cantilevered Floors.....	142
Preparing for Foundation or Floor Insulation	143
Rim-Joist Insulation and Air-Sealing.....	143
Installing Floor Insulation.....	143
Installing Fiberglass Batt Floor Insulation.....	147
Crawl-Space Wall Insulation	148
Basement Insulation.....	150
SWS Alignment.....	154

7: Windows and Doors

Storm Windows	155
Exterior Aluminum Storm Windows.....	155
Interior Storm Windows	157

Window Repair and Air Leakage Reduction	158
Double-Hung Window Weatherization	158
Weatherstripping Double-Hung Windows.....	159
Window Replacement Specifications	161
Window Energy Specifications	162
Removing Old Windows	162
Replacing Nailing-Fin Windows	163
Block-Frame or Finless Windows	165
Flush-Fin Window Replacement	168
Window Safety Specifications	169
Windows Requiring Safety Glass	169
Fire Egress Windows.....	171
Door Replacement and Improvement	172
Door Replacement	172
Door Adjustment and Repair.....	173
SWS Alignment.....	175

8: Heating and Cooling Systems

HVAC-System Commissioning & Education	176
HVAC-System Commissioning	177
Multi-Family HVAC-System Education.....	177
Combustion-Safety Evaluation	178
Leak-Testing Gas Piping	179
Carbon Monoxide (CO) Testing	180
Worst-Case CAZ Depressurization Testing.....	181
Evaluating Combustion Air	187
Combustion and Ventilation Air.....	187
The Standard Method	188
Known Air Infiltration Rate (KAIR) Method.....	188
Connecting Indoor Spaces.....	189
Combustion Air from Outdoors	190
Mitigating CAZ Depressurization and Spillage.....	192

Combustion-Air-Related Solutions	193
Electronic Combustion Analysis	195
Critical Combustion-Testing Parameters	197
Heating System Replacement	199
Furnace or Heat Pump Replacement	199
Gas-Fired Heating Installation	203
Combustion Boiler Replacement	205
Oil-Fired Heating Installation	208
Evaluating Oil Tanks	211
Combustion Space Heater Replacement	212
Space Heater Operation	213
Unvented Space Heaters	213
Gas Burner Safety & Efficiency Service	214
Combustion Efficiency Test for Furnaces	214
Inspecting Gas Combustion Equipment	215
Testing and Adjustment	216
Oil Burner Safety and Efficiency Service	217
Oil Burner Testing and Adjustment	218
Oil Burner Inspection and Maintenance	221
Inspecting Furnace Heat Exchangers	278
Wood Stoves	225
Wood-Stove Clearances	225
Wood Stove Inspection	227
Inspecting Venting Systems	229
Vent Connectors	230
Chimneys	233
Masonry Chimneys	233
Manufactured Chimneys	237
Chimney Terminations	238
Decommissioning Chimneys	239
Special Venting Considerations for Gas	239
Venting Fan-Assisted Furnaces and Boilers	239
Venting Sealed-Combustion Furnaces and Boilers	242

Sidewall Power Venting	242
Ducted Air Distribution	243
Sequence of Operations	244
Solving Airflow Problems	244
Unbalanced Supply-Return Airflow Test.....	248
Evaluating Furnace Performance.....	251
Package Units (Air Handlers)	253
Recommended Airflow for Air Handlers	256
Improving Forced-Air System Airflow	256
Air Filtration for Air Handlers.....	259
Evaluating Duct Air Leakage	260
Troubleshooting Duct Leakage	261
Measuring Duct Air Leakage with a Duct Blower.....	264
Measuring House Pressure Caused by Duct Leakage..	267
Sealing Duct Leaks	268
General Duct-Sealing Methods.....	268
Sealing Return Ducts	269
Sealing Supply Ducts	270
Materials for Duct Sealing.....	273
Duct Insulation	273
Spray Foam Duct Insulation.....	275
Hot-Water Space-Heating Distribution	275
Boiler Efficiency and Maintenance	275
Hydronic Distribution System Improvements.....	277
Steam Heating and Distribution.....	280
Steam Pressure Limits	280
Steam System Maintenance	281
Steam System Energy Conservation.....	282
Converting Steam Distribution to Hot Water	285
Programmable Thermostats	286
Electric Heat.....	287
Electric Baseboard Heat.....	287
Electric Furnaces	288
Central Heat-Pump Energy Efficiency	289

Room Heat Pumps	293
Ductless Minisplit Heat Pumps	295
Evaluating Ducted Central Air-Conditioning Systems ...	296
Central A/C-Heat Pump Inspection and Maintenance .	297
Air-Conditioner Sizing	299
Evaluating Air-Conditioner Charge	301
SWS Alignment	301

9: Ventilation

Pollutant Control	302
Pollution-Control Checklist	303
ASHRAE Standard 62.2–2016 Ventilation	304
ASHRAE 62.2–2016 Components	304
Whole-Dwelling Ventilation Requirement	304
Local Exhaust Ventilation Requirement	305
Infiltration Credit	307
Fan and Duct Specifications	307
Fan Specifications	308
Termination Fittings	309
Duct Sizing	311
Duct Materials and Installation	312
Commissioning Ventilation Systems	313
Whole-Dwelling Ventilation Systems	313
Exhaust Ventilation	314
Supply Ventilation	316
Balanced Ventilation	317
Rooftop-Unit (RTUs) Economizer Ventilation	319
Garage Exhaust Ventilation	320
Multifamily Ventilation	321
Air Filtration for Indoor Air Quality	322
Installing Filters for Outdoor Air	323
Adaptive Ventilation	323

Attic Ventilation	324
Attic Ventilation as a Solution for Moisture Problems .	324
When to Install Attic Ventilation.....	325
Attic Ventilation Requirements	325
Power Ventilators	327
Unventilated Attics	327
Crawl Space Ventilation.....	328
Naturally Ventilated Crawl Spaces.....	328
Conditioned Crawl Spaces	329
Ventilation for Cooling.....	329
Whole-House Fans	330
SWS Alignment.....	330

10: Baseload Measures

Refrigerator Replacement and Maintenance.....	333
Refrigerator Replacement	334
Refrigerator Cleaning and Tuning.....	335
Refrigerator Metering Protocol.....	336
Electronic Entertainment and Computers	340
Lighting-Efficiency Improvements	341
LEDs versus CFLs	341
Light Color	341
Daylighting	342
Home Lighting Retrofit Equipment.....	342
Reducing Fixture Wattage in Over-Lit Areas	344
Clothes Dryers Service and Venting	347
Water-Heating Energy Savings.....	349
Water-Saving Shower Heads and Faucet Aerators	350
Water Heater Blankets.....	351
Measuring and Adjusting Hot Water Temperature	353
Heat Traps and Water-Heater Pipe Insulation.....	354

- Selecting Storage Water Heaters 355
 - Determining a Storage Water Heater’s
Insulation Level 355
 - Storage Water-Heater Selection..... 357
- Alternative Water-Heaters 357
 - Sidewall-Vented Gas Storage Water Heaters..... 357
 - On-Demand Gas Water Heaters 358
 - Heat Pump Water Heaters 358
- Water Heater Installation 360
- Comparing Water Heaters 361
 - Safety Comparison 361
 - Reliability Comparison..... 362
 - Efficiency and Energy Cost Comparison 362
- SWS Alignment..... 363

11: Mobile Homes

- Mobile Home Heating 365
 - Furnace Maintenance and Energy Efficiency..... 367
 - Furnace Replacement 367
- Mobile Home Cooling Systems..... 368
 - Air-Conditioning Systems..... 368
 - Mobile Home Ventilation Systems 369
- Mobile Home Air Sealing..... 369
 - Shell Air Leakage Locations 370
 - Duct Leak Locations 370
- Mobile Home Insulation 374
 - Insulating Mobile Home Roof Cavities..... 374
 - Mobile Home Sidewall Insulation 380
 - Mobile Home Floor Insulation..... 382
- Mobile Home Windows and Doors 385
 - Mobile Home Storm Windows 386
 - Replacing Mobile Home Windows 387
 - Mobile Home Doors 388

Mobile Home Skirting.....	388
SWS Alignment.....	388

12: Air Leakage Diagnostics

Shell Air-Leakage Fundamentals	389
Goals of Air-Leakage Testing.....	389
Single-Family Airtightness Testing	391
Blower-Door Principles	391
Preparing for a Blower Door Test.....	393
Blower-Door Test Procedures	394
Approximate Leakage Area	396
Multifamily Airtightness Testing.....	397
Testing Equipment	397
Multifamily Air Leakage.....	399
Multifamily Blower-Door-Test Strategies	399
Testing Air Barriers	403
Simple Pressure Tests.....	405
Simple Zone Pressure Testing.....	407
SWS Alignment.....	411

Appendices 412

R-values for Common Materials
ASHRAE 62.2 Duct Sizing
Fire Testing and Rating
Carbon Monoxide Limits
Refrigerator Dating Chart
DOE Health and Safety Guidance
Pressure Diagnostics – Hole Size Ratios
House Depressurization Chart

Glossary

Directions for how to search this document with ease, accuracy, and thoroughness.

CHAPTER 1: HEALTH AND SAFETY

Refer to OSHA, NIOSH, EPA, WPN 17-7, SWS, BPI and AHJ

The chapter begins with health, safety, and durability of buildings. If health and safety problems affect the cost effective ECMs you select, solve problems before or during the weatherization work.

Client Health and Safety

Building fires, moisture problems, carbon monoxide poisoning, and lead paint poisoning are health and safety concerns.

Alert residents to health and safety hazards you find. Discuss known or suspected health concerns with occupants; take extra precautions based on occupant sensitivity to environmental hazards, such as chemicals and allergens.

- ✓ Inspect the building for fire hazards such as improperly installed electrical equipment, flammable materials stored near combustion appliances, or malfunctioning heating appliances. Discuss these hazards with occupants and remove these hazards.
- ✓ Understand and comply with the fire containment code requirements of the IRC.
- ✓ Test combustion appliance for CO and related hazards. Measure CO in the ambient air. Investigate and eliminate CO.
- ✓ Test combustion appliances for CO and related hazards. Measure carbon monoxide in the ambient air. Investigate and eliminate CO.
- ✓ Identify and document moisture problems and discuss with the occupant. Solve moisture problems before or during weatherization work.
- ✓ Obey the EPA RRP and IHADA lead(Pb) hazard rules when working on buildings constructed before 1978. Obey any other applicable lead paint rules and regulations.

1.1 EDUCATE OCCUPANTS AND BUILDING OPERATORS

Refer to DOE WPN 17-7, IHEDA State Plan, and SWS

Homes and multifamily buildings harbor a variety of hazards. Educate occupants, landlords, and building operators about the health and safety hazards and the improvements that you make to mitigate these hazards.

- ✓ Discuss health or safety hazards you see with fellow workers, occupants, and building operators, and discuss how to mitigate the hazard.
- ✓ Suggest contacting specialists to mitigate particular hazards if appropriate.
- ✓ Explain equipment operation and maintenance (O&M).
- ✓ Provide an O&M procedures manuals and manufacturers' equipment specifications as appropriate.
- ✓ Instruct occupants to remove combustible materials near ignition sources.
- ✓ Inform occupants and staff about smoke alarms, carbon monoxide alarms and combination alarms. Explain their functioning.
- ✓ Suggest that occupants or staff remove or isolate indoor air quality hazards such as pesticides, petroleum products, and solvents.

1.2 FIRE SAFETY

- ✓ The building codes focus on preventing the spread of fire within and between buildings. A fire barrier is a tested and certified wall assembly that can withstand and contain a fire for a particular time duration.
- ✓ A fire partition is a fire barrier that prevents the spread of fire between the sections of a building. A firewall is a structural fire barrier between buildings that is designed to remain standing during and after a fire.
- ✓ Flame spread is a tested value of how fast a material burns compared to red oak planks.

A thermal barrier is a sheeting material that protects the materials behind it from reaching a temperature of 200 degree F or breaching it during a fire. Drywall is the most common thermal barrier.

An ignition barrier is a material used with foam insulation to prevent the foam from igniting. The code specifies a number of materials that can serve as ignition barriers including drywall, plywood, fibrous insulation, galvanized steel, and intumescent paint.

1.3 CARBON MONOXIDE (CO)

SWS Detail: 2.0102 CO Alarms; 5.05 Combustion Safety; ANSI/BPI 1200

Carbon monoxide is a colorless, odorless, poisonous gas. The two common terms for expressing measured CO concentration are these:

1. “as measured” which compares CO molecules to air molecule in parts per million (ppm).
2. "air free”, which is a value calculated from the as measured CO and the measured oxygen in combustion gases. Air free denotes what the CO concentration would be in an air-free sample of combustion gases.

Measure ambient CO levels outside and inside. Investigate any CO levels inside that are higher than what was measured outside. Refer to ASI/BPI 1200 for action levels.

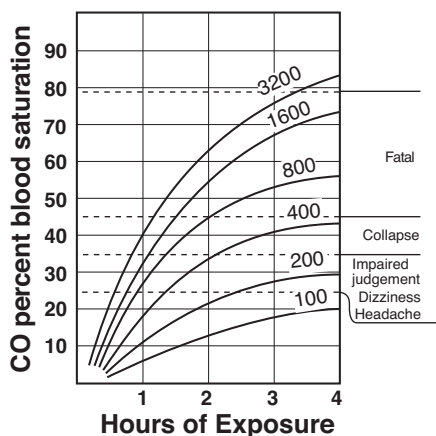

Effects of CO: This graph's 6 curves represent different CO exposure levels in PPM (parts per million).

1.3.1 Causes of Carbon Monoxide (CO)

CO is released by unvented gas space heaters, kerosene space heaters, backdrafting vented space heaters, gas ranges, leaky wood stoves, and motor vehicles idling near the building. Central furnaces and boilers that backdraft may also lead to high levels of CO.

The following conditions cause CO:

- A combustion appliance is overfired compared to its rated fuel input.
- Backdrafting combustion gases smother the flame.
- An object interferes with the flame (a pan over a gas burner on a range top, for example).
- Too little combustion air.
- Rapidly moving air interferes with the flame.
- Burner misalignment causes a distorted flame.
- Flue or heat exchanger blockage interferes with the flow of flue gases.

Measure CO at the exhaust port of the heat exchanger. Identify and correct CO problems.

Testing for Carbon Monoxide (CO)

The most common CO test instruments use electronic sensors with a digital display showing parts per million (ppm). Read the manufacturer's instructions on zeroing the meter. CO test equipment must be maintained and calibrated per manufacturers recommendations.

Air-free CO measurement includes both CO and O₂ sensing with a calculation to find the CO concentration in undiluted flue gases that contain no oxygen.

Technicians must test for CO before, during and after weatherization is completed.

1.4 SMOKE AND CARBON MONOXIDE (CO) ALARMS

SWS Detail: 2.0101 Smoke Alarms; 2.0102 CO Alarms

Every dwelling must have at least one smoke alarm and one CO alarm. Install these alarms on each level, near the bedrooms.

Install CO alarms, smoke alarms, or combination CO/smoke alarms in all dwellings that don't have functional alarms. Check all existing alarms in the home for proper operation.

Smoke and CO alarms are to be installed per manufacturers installation recommendations.

1.4.1 Occupant Education about Alarms

- ✓ Educate occupants about what to do if the alarm sounds.
- ✓ Alert residents to the possibility of false alarms from smoking, cooking and forest fires.

1.4.2 Smoke Alarms

SWS Detail: 2.0101 Smoke Alarms

Install smoke alarms which comply with the SWS in buildings where they don't exist or don't work.

- ✓ Install at least one smoke alarm in each dwelling on each floor.
- ✓ Install smoke alarms per manufacturer's recommendations.
- ✓ Installation must comply with the SWS.
- ✓ Be aware of local ordinances.
- ✓ Install alarms with 10 year non-replacable battery

1.4.3 CO Alarms

SWS Detail: 2.0102 Carbon Monoxide Alarms; 5.05 Combustion Safety

- ✓ Install at least one carbon monoxide alarm in each dwelling on each floor.
- ✓ Install carbon monoxide alarms per manufacturer's recommendations.
- ✓ Installation must comply with the SWS
- ✓ Be aware of local ordinances.
- ✓ Install alarms with 10 year non-replacable battery.

1.5 GAS RANGE AND OVEN SAFETY

SWS Details: Safety Devices 2.01; General Duct Sealing 5.0106.1; Duct Insulation 5.0107; Appliance Venting 5.0503; Combustion Safety 5.05; Natural Gas/Propane Fuel Piping 5.0504; Equipment Removal 5.8801; Local Ventilation 6.02; Kitchen Range Hoods 6.0201.2; Exhaust Ventilation 6.0302; BPI/ANSI 1200

Gas ovens can release CO, natural gas, or propane into a kitchen. Test the burners for safe combustion with these steps and complete the recommended improvements.

1. Test for gas leaks in the gas piping in and around the range and oven and seal leaks.
2. Turn the oven burner and then range burners to high one-by-one. Inspect the flames and test them for CO. For the oven burner test at its outlet. For range burners, hold the test probe approximately 8 inches above the flame.
3. If the CO reading for the oven exceeds 225 ppm or any of the range top burners exceed 100 ppm, clean and tune the burner.
4. For range tops, if after servicing, the CO level still exceeds 100 ppm, install a CO alarm in the same room as the appliance and perform client education on use of the range. Consider a kitchen rated CO alarm.
5. For ovens, if after servicing, the CO level still exceeds 225 ppm, install a CO alarm in the same room as the appliance. Install a kitchen exhaust fan (minimum 100 cfm) to vent the CO to the exterior OR replace the range if a fan is not an option. Consider a kitchen rated CO alarm.
6. DOE funds cannot be used to replace ranges.
7. LIHEAP funds can be used to replace ranges.



AIR SHUTTERS



ORIFICE-CLEANING MULTITOO



ORIFICE

7. Burner orifices can clog. Clean dirty orifices with a multi-tool designed for cleaning various sizes of orifices.
8. Adjust the burner's air shutters to stabilize and harden the flame and reduce yellow-tipping, which should also reduce the CO concentration.

Caution: To protect yourself and the occupants, measure CO in the ambient air in the kitchen during these tests. If the ambient CO reading is 70 ppm or more, discontinue the testing and evacuate unit. Refer to ANSI/BPI 1200.

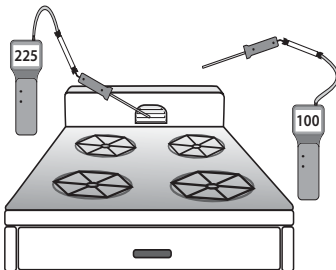

CO from range and oven: Measure CO at oven in undiluted flue gases.

Client Education about Ranges

Educate clients about the following safety practices in using their gas range.

- ✓ Never use a range burner or gas oven as a space heater.
- ✓ Open a window, and turn on the kitchen exhaust fan when using the range or oven.
- ✓ Never install aluminum foil around a range burner or oven burner because the foil could interfere with the flame.
- ✓ Keep range burners and ovens clean to prevent dirt from interfering with combustion.
- ✓ Burners should display hard blue flames.

1.6 REDUCING MOISTURE PROBLEMS

SWS Detail: Moisture 2.02

1.6.1 Moisture Sources and Effects

Water or material wetting due to high relative humidity, bulk water intrusion, and/or plumbing leaks reduce the thermal resistance of building materials. Moisture can cause respiratory distress, property damage, and increased energy bills.

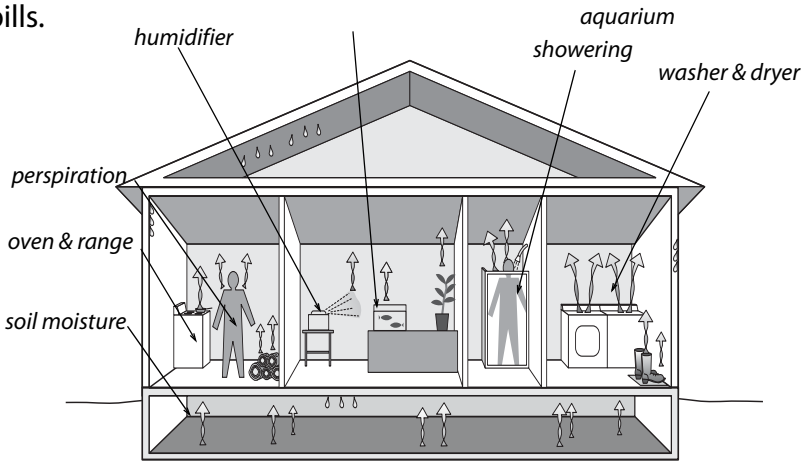

Moisture sources: Household moisture can often be controlled at the source by informed and motivated occupants, who work to control moisture sources like these.

1.6.2 Moisture Reduction Strategies

1. Reduce moisture sources such as roof leaks, plumbing leaks, and standing water around the building perimeter.
2. Install air and vapor barriers.
3. Provide mechanical ventilation.

Table 1-1: Moisture Sources and Their Potential Contributions

Moisture Source	Potential Amount Pints
Ground moisture	0–105 per day
Unvented combustion space heater	0.5–20 per hour
Seasonal evaporation from materials	6–19 per day
Dryers venting indoors	4–6 per load
Dish washing	1–2 per day
Cooking (meals for four persons)	2–4 per day
Showering	0.5 per shower

1.6.3 Symptoms of Moisture Problems

SWS Detail: Moisture 2.02; Air sealing General Pressure Boundary 3.01

Condensation on windows, walls, and other cool surfaces signals high relative humidity. Occasional condensation isn't a major problem. If condensation happens frequently, take action to reduce moisture sources.



Dry rot



Termites



Efflorescence and Spalling

Efflorescence is a white, powdery deposit left by water that moves through masonry and leaves minerals behind as it evaporates from the masonry surface. Masonry materials experience spalling with efflorescence that deteriorates their surfaces.

1.6.4 Solutions for Moisture Problems

SWS Detail: Drainage 2.0201; Ground Vapor Retarder 2.0202; Space Conditioning 2.0203; General Pressure Boundary 3.01; Shell Components 3.02; Local Ventilation 6.0201; Whole Building Ventilation 6.03; Laundry 7.0105; Spas, Hot Tubs, Saunas 7.8802

- ✓ Install vapor/air barriers where appropriate.
- ✓ Verify that clothes dryers and exhaust fans vent to the outdoors.
- ✓ Seal water leaks in the foundation.



**UNVENTED
SPACE HEATER**



WATER POOLING



DUCT CONDENSATION

- ✓ Seal water leaks in the roof.
- ✓ Remove unvented space heaters.
- ✓ Educate clients about moisture related issues.
- ✓ Insulate surfaces prone to condensation.
- ✓ When bulk water enters a crawlspace or basement, a sump pump is an effective remedy.
- ✓ Ventilation can be used to address indoor humidity

Prevention is the best solution of moisture issues and can extend the durability of the building. building's durability.

1.6.5 Crawl Space Moisture and Safety Issues

Cover ground with an airtight vapor barrier to prevent the movement of moisture and soil gases from the ground into the dwelling using these procedures.

- ✓ Remove debris that can cause injury or puncture vapor barrier.
- ✓ Remove biodegradable matter.
- ✓ Cover ground completely with a minimum of 6 mil vapor barrier.
- ✓ Seams must overlap at least 12 inches. Seal the edges and seams with manufacturer approved sealant.
- ✓ All surfaces that pose the potential to allow air or moisture movement into the subspace must be covered with an air barrier/moisture barrier.
- ✓ The barrier must be continuous and run from the termite inspection strip down the foundation wall and across the subspace floor.
- ✓ If subspace wall barrier is installed separately from ground barrier you must install the wall barrier first. You begin by installing the wall barrier at the termite inspection line down to the ground and then extending the wall barrier 12" horizontally across the subspace floor. Next install ground barrier across the floor and then extending at least 6" up the foundation wall over the wall barrier.
- ✓ Fasten the wall barrier with manufacturer approved sealant. Attach termination strips over the sealant and secure with masonry fasteners.
- ✓ Any gaps or uneven surfaces between the barrier/termination strip and the foundation or piers may be filled with foam.
- ✓ You shall not use foam as the primary sealant
- ✓ Provide negative pressure in the crawl space with reference to the building during weatherization.

1.6.6 Ground Moisture Source Reduction

Observe the following specifications to avoid building deterioration from ground moisture. Moisture problems must be corrected before airsealing.



Sump pump: Pumps water out of a sump or basin where water collects in a basement or crawl space.

- ✓ Verify that the ground outside the building slopes away from the foundation or that water doesn't puddle near the foundation when problematic.
- ✓ Install or repair rain gutters/downspouts as necessary.
- ✓ Install a sump pump for crawl spaces or basements with a history of flooding. Installation must comply with the SWS and manufacturer's specifications.
- ✓ If installing crawl space ventilation ensure it follows applicable code.
- ✓ Repair plumbing and sewer leaks

1.7 POLLUTANTS SOURCE CONTROL

Radon and asbestos are hazards to both occupants and weatherization professionals.

1.7.1 Radon

SWS Details: 2.0401 Radon Precautionary Measures; 2.0401.1 Soil Gas Retarder; 2.0401.2 Sump well/Pit covers; 2.0401.3 Drain fittings

Radon is a dangerous indoor air pollutant that comes from the ground through the soil. The EPA predicts about 20,000 lung cancer deaths per year, caused by radon exposure.

The EPA believes that any building with a radon concentration above 4 pico-Curies per liter (pCi/l) of air should be modified to reduce the radon concentration.

Every Indiana county has been determined to be a Zone 1 or Zone 2 county. Zone 1 counties have the highest potential for radon, at >4 pCi. Zone 2 counties have a moderate potential for radon at 2-4 pCi.

Ground-moisture barriers and foundation air sealing may reduce radon concentrations in addition to reducing moisture migration and air leakage.

Radon Mitigation

DOE funds cannot be utilized to pay for radon mitigation.

See WPN 17-7 for additional radon information.

1.7.2 Asbestos Containing Materials (ACM)

Refer to EPA, OSHA, and AHJ

The EPA classifies asbestos as a known carcinogen. The following materials may contain asbestos: pipe insulation, duct insulation, floor tile, siding, roofing, vermiculite, and other building materials. Weatherization professional must recognize materials that may contain asbestos and avoid disturbing them.

Refer to WPN 17-7 for additional asbestos guidance.

- When suspected asbestos containing materials are present, assume that asbestos is present unless testing has determined otherwise.
- Sample collection and testing must be done by a certified tester and in compliance with WPN 17-7, EPA, OSHA
- Asbestos testing is an allowable cost by DOE.
- Follow Client Education guidance outlined in WPN 17-7.
- **Unless the suspect ACM has tested negative for asbestos, the dwelling must be pressurized when utilizing the blower door.**
- Utilize proper PPE when ACM or suspected ACM are present.

1.7.3 Lead-Safe Procedures

Refer to EPA, OSHA, IHCDA and AHJ for guidance and laws

The EPA's Lead-Safe Renovation, Repair, and Painting (RRP) rule is a legal mandate for weatherization work.

Lead dust is dangerous and can cause negative health effects in people and animal exposed to it.

Lead paint was commonly used in homes built before 1978. Weatherization professional working on these older homes and creating disturbances in or on the home must perform EPA approved testing to rule out its presence.

When working on dwellings with positive lead testing results, all EPA RRP and IHCDA requirements apply. Follow all other applicable lead rules/regulations.

IHCDA requires compliance to the "We Care About Lead" policy as outlined in the IHCDA Weatherization State Plan.

1.8 ELECTRICAL SAFETY

SWS Detail: 2.03 Electrical: 2/0301 High voltage (50 volts or more); 2.0301.2 Knob and tube wiring--isolation

Electrical hazards are serious safety concerns. Observe local codes and the following specifications for electrical safety.

- ✓ When any weatherization, work requires working with high voltage power (50 V or greater), a licensed electrician, or a qualified technician must do the procedure.
- ✓ When working around wiring, use a voltage tester to determine if circuits are live. Turn circuits off at circuit breakers as appropriate.
- ✓ Confirm wire splices are enclosed in electrical junction boxes. If you cover a junction box with insulation, you must attach a flag to mark its location.
- ✓ Don't allow metal insulation shields to contact wiring.
- ✓ Verify that the electrical system is grounded to a ground rod or a metallic water pipe with an uninterrupted electrical connection to the ground.
- ✓ Use a generator to power insulation blowers and other large power tools.



Voltage tester: Test voltage wires near your work area and take action to disconnect the circuit if appropriate.

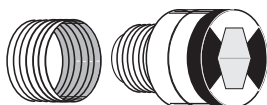

S-type fuse: An S-type fuse prohibits residents from oversizing the fuse and overloading an electrical circuit.

1.8.1 Decommissioning Knob-and-Tube Wiring

SWS Detail: 2.0301.3 Knob and tube wiring--isolation

Decommission knob-and-tube wiring before or during weatherization when applicable.

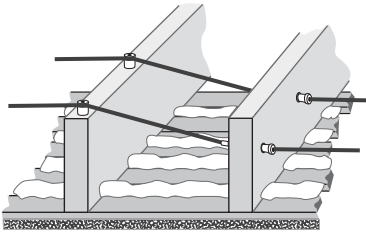

Knob and tube wiring: Replace obsolete and worn wiring during energy retrofit work so that workers can insulate building cavities sufficiently.

All knob and tube wiring must be tested to determine if it is live. If you are unsure about whether the wiring is still live and/or safe, schedule an inspection by a qualified professional to make the determination.

If the knob and tube wiring is live and safe you may construct a compliant dam around the wiring. If the wiring is unsafe, you must replace it with code approved wiring and methods.

1.8.2 Constructing Shielding for Knob-and-Tube Wiring

SWS Detail: 2.0301.2 Knob and Tube Wiring

When knob and tube wiring is NOT going to be decommissioned or replaced, the integrity of the wiring circuit should be evaluated before work can be completed on the home. Once the circuit integrity has been verified, work may be performed around the knob and tube wiring without disturbing it.

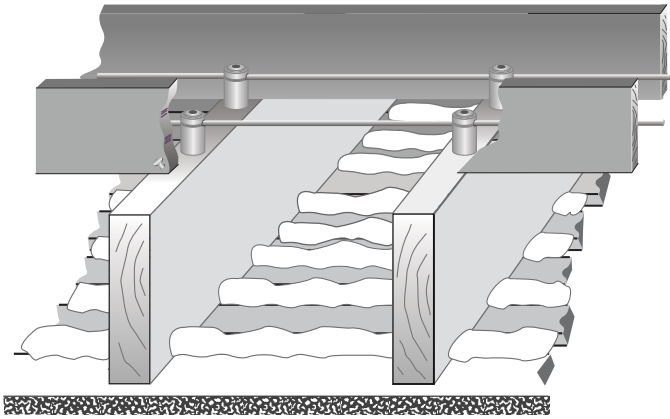

Shielding knob and tube: If you can't decommission knob-and-tube wiring, you may construct a dam to shield the wiring from insulation.

- ✓ Construct a dam to maintain a minimum 3-inch clearance between attic insulation and knob-and-tube wiring. Do not cover the knob-and-tube wiring.
- ✓ You must flag the shielding structure.
- ✓ Do not insulate wall cavities that contain knob and tube wiring. Decommissioning of the wiring would be required before insulating.

1.9 WORKER HEALTH AND SAFETY

Refer to OSHA for complete guidance

The personal health and safety of weatherization professionals is important. Injuries are the fourth leading cause of death in the United States. Long-term exposure to toxic materials contributes to workers' sickness, absenteeism, and death. Both injury hazards and toxic substances exist during weatherization work.

The Occupational Safety and Health Administration (OSHA) establishes workplace safety standards. Weatherization staff and contractors must attend training on OSHA standards and observe these standards on the job. Safety always has priority over other factors affecting weatherization operations.

1.9.1 Commitment to Safety

Safety requires commitment, awareness, communication, and action. Every weatherization professional in Indiana is required to hold a minimum of OSHA 10 . IHCDCA supports OSHA training for all weatherization professionals.

INCAA provide OSHA 10 training as well as fit testing for respirators once the candidate obtains medical clearance to don a respirator.

Safety education: Safety meetings are an essential part of a successful safety program.

1.9.2 New Weatherization Professionals

Follow your employers on-boarding program and IHCDCA requirements for safety training.

1.9.3 Driving

According to the Bureau of Labor Statistics, one-third of all occupational fatalities in the United States occur in motor-vehicle accidents. Follow your employers OSHA aligned Driving Safety Protocols.

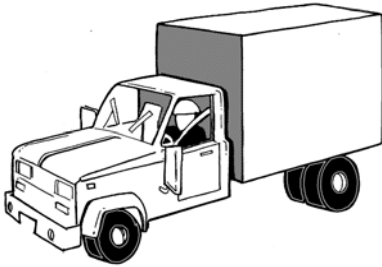

Safe vehicles: Maintain vehicles in good repair. Drivers and passengers should always wear seat belts.

1.9.4 Lifting and Back Injuries

Back injuries account for one out of every five workplace injuries. Most of these injuries are to the lower back and result from improper lifting, crawling in tight spaces, and using heavy tools. Follow your employers OSHA aligned Injury and Illness Prevention Program.

1.9.5 Respiratory Health

Follow your employer's OSHA aligned Respiratory Protection Program.

Per OSHA regulation 1910.134: A respirator shall be provided to each employee when such equipment is necessary to protect the health of such employee. The employer shall provide the respirators which are applicable and suitable for the purpose intended. Agencies and contractors requiring installers to wear respiratory protection will have a written respiratory protection plan.

1.9.6 Hazardous Materials

Refer to Safety Data Sheets

OSHA regulations require employers to notify and train employees about hazardous products used on the job. Follow your employers OSHA aligned HAZ-COM Program.

Personal protective equipment:
Employees should own and maintain protective equipment to protect themselves from hazardous materials.

1.9.7 Falls

Falls off ladders and stairs cause 13% of workplace injuries according to the National Safety Council. Follow your employers OSHA aligned Fall Prevention Program.

1.9.8 Tool Safety

About 90,000 people hurt themselves with hand tools each year. The crew chief should conduct tool-safety training as frequently as necessary to ensure safe tool use. Follow your employers OSHA aligned Tool Safety Program. Also, follow the tool manufacturer guidelines.

1.9.9 Safety for Crawl Spaces and Other Confined Areas

The Occupational Safety and Health Administration (OSHA) defines a confined space as a space that contains a hazard like confinement, limited access, or restricted airflow because of its small size. Follow your employer's OSHA aligned Confined and Permit Required Entry Program.

1.9.10 Safety for Extreme Weather

Refer to OSHA and NIOSH

Extreme weather is a common cause of job-related sickness and injury. You can avoid sickness and injury by awareness and preventive measures.

Hot Weather Safety

Know the signs of heat ailments and take action if you or a co-worker experiences the beginning of symptoms. Observe these hot-weather suggestions for staying cool and preventing heat ailments.

- ✓ Follow NIOSH heat related illness and treatments.
- ✓ Comply with OSHA Heat Related Illness Prevention Index

CHAPTER 2: ENERGY AUDITS AND QUALITY CONTROL INSPECTIONS

This chapter outlines the operational process of energy audits, work orders, and final inspections as practiced by non-profit agencies and contractors working in the Department of Energy's (DOE) Weatherization Assistance Program (WAP).

WAP's Mission

The mission of DOE WAP is **“To reduce energy costs for low-income families, particularly for the elderly, people with disabilities, and children, by improving the energy efficiency of their homes while ensuring their health and safety.”**

Applicable DOE Policy

Comply with DOE Policy as expressed by Weatherization Program Notices (WPNs) that DOE issues. Also comply with the NREL's Standard Work Specifications (SWS).

Why We Care about Health and Safety

The health and safety of clients must never be compromised. Weatherization work can change the operation of HVAC systems, alter the moisture balance in the home, and reduce a home's natural ventilation rate. Weatherization professionals must take precautions to avoid harm from these changes.

2.1 PURPOSES OF AN ENERGY AUDIT

An energy audit evaluates a home's existing condition and outlines improvements to the energy efficiency, health, safety, and durability of the home.

An energy audit must follow NREL's Energy Auditor Job Task Analysis:

- Domain I: Collection of material, visual, dimensional and appliance information about the building for an energy audit
- Domain II: Diagnostic testing of a dwelling unit for an energy audit
- Domain III: Evaluation of collected energy audit data to determine the scope of work

2.1.1 Energy-Auditing Judgment and Ethics

The auditor's good decisions are essential to the success of a weatherization program.

- ✓ Understand the policy of the DOE and IHCDA WAP program.
- ✓ Follow NREL's Job Task Analysis
- ✓ Treat every client with respect.
- ✓ Communicate clients, coworkers, contractors, and supervisors.
- ✓ Know the limits of your authority and ask for guidance when needed.
- ✓ Develop and maintain the skills necessary for energy auditing.
- ✓ Choose ECMs according to their cost effectiveness.

2.1.2 Energy Auditing Recordkeeping

- ✓ The client file is the record of a weatherization job. See the Indiana WAP Policy and Procedures manual for minimum contents required in the completed client file.

2.1.3 Communication Best Practices

Friendly, honest, and straightforward communication creates an atmosphere where the auditor and clients can discuss problems and solutions openly. Auditors must communicate clearly and directly.

- ✓ Introduce yourself, identify your agency, and explain the purpose of your visit.
- ✓ Make sure that the client understands the goals of the WAP program.
- ✓ Listen carefully to your client regarding their home.
- ✓ Ask questions to clarify your understanding of your client's concerns.
- ✓ Before you leave, give the client a summary of what you found and set future expectations .
- ✓ Avoid making promises until you have time to finish the audit, produce a work order, and schedule the work.

2.1.4 Client Interview

The client interview is an important part of the energy audit. Even if clients have little understanding of energy and buildings, they can provide useful observations that can save you time.

- ✓ Ask the client about comfort problems, including which rooms are cold or warm.
- ✓ Ask clients to see their energy bills.
- ✓ Ask clients if there is anything relevant they notice about the performance of their mechanical equipment.
- ✓ Complete the IHCDA Occupant Health Screening form.
- ✓ Discuss space heaters, fireplaces, attached garages, and other combustion hazards.
- ✓ Discuss drainage issues, wet basements or crawl spaces, leaky plumbing, and pest infestations.

- ✓ Discuss the home's existing condition and how the home may change after the proposed retrofits.
- ✓ Notify the client of any necessary measures that will change the aesthetics or operation of the dwelling.
- ✓ Identify existing damage to finishes to ensure that weatherization workers are not blamed for existing damage. Document damage with photographs.
- ✓ Ask the client to sign necessary forms.

2.1.5 Deferral of Weatherization Services

When you find major health, safety, or durability problems in a home, sometimes it's necessary to postpone weatherization services until those problems are solved. The problems that are cause for deferral of services include but are not limited to the following.

- Roof leaks
- Major foundation damage.
- Moisture problems including mold or insect infestation.
- Major plumbing problems.
- Human or animal waste in the home.
- Major electrical problems or fire hazards.
- The home is vacant or the client is moving.
- The home is for sale.
- Behavioral issues from client
- Illegal activity.
- Hoarding.
- Uncooperative or abusive client.

2.2 PARTS OF AN ENERGY AUDIT

Visual inspection, diagnostic testing, and numerical analysis are three types of energy auditing procedures we discuss in this section. These procedures help energy auditors to evaluate all the possible ECMs that are cost effective according to DOE-approved energy-modeling software:

The energy audit must also propose solutions to health and safety issues.

YOUR NOTES:

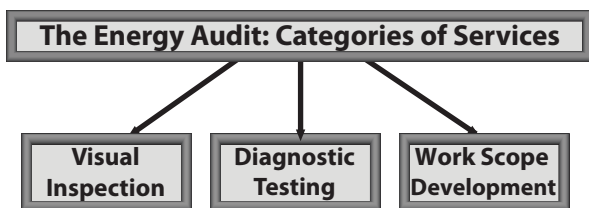

2.2.1 Visual Inspection

Refer to the [NREL EA JTA: Domain 1](#) for full visual inspection tasks. Below is a sampling of Tasks associated Domain 1.

- Document energy consumption
- Document building history
- Conduct a physical/visual inspection
- Collect health and safety data
- Collect appliance and base load information
- Identify a conditioned building enclosure
- Collect mechanical ventilation data
- Identify building insulation
- Collect attic data
- Collect wall data
- Collect foundation and subspace data
- Collect roof data

2.2.2 Diagnostic Testing

Refer to the [NREL EA JTA: Domain 2](#) for full diagnostic data collection. Use diagnostic tests as appropriate during the energy audit.

- Prepare the dwelling unit for test(s)
- Test the electric appliances
- Conduct indoor air quality tests
- Determine the safety and efficiency of combustion appliances
- Determine air leakage of building envelope
- Determine the performance of HVAC distribution

2.2.3 Work Scope Development

Energy auditors currently use NEAT/MHEA/Multea to determine which ECMs have the highest Savings-to-Investment Ratio (SIR). The ECMs with the highest SIRs are at the top of the priority list. Utilize the [NREL EA JTA: Domain III](#)

$$\text{SIR} = \text{LIFETIME SAVING} \div \text{INITIAL INVESTMENT}$$

DOE WAP and the State WAP program require that ECMs have an SIR or 1 or greater. Subgrantees must install ECMs with higher SIRs before ECMs with lower SIRs.

Refer to the NREL EA JTA: Domain 3 for full evaluation of collected energy audit data to determine the scope of work.

Evaluate the health and safety data

Evaluate the durability/structural integrity of the building

Evaluate the HVAC system

Evaluate the mechanical ventilation

Evaluate energy use

Evaluate foundations/subspaces, walls, attics, windows and doors

Use energy modeling software, e.g., NEAT/MHEA/Multea

Generate the recommended work scope

2.3 WORK ORDERS

Refer to EA JTA Domain III; NEAT/MHEA/Multea manual; DOE Appendix A.

The work order is a list of materials and tasks that are recommended as a result of an energy audit.

- ✓ Evaluate which ECMs have an acceptable savings-to-investment ratio (SIR) using the energy-modeling software .
- ✓ Determine how health and safety issues will be addressed
- ✓ Determine if health and safety issues can be addressed within the budgetary constraints of the program
- ✓ Provide detailed specifications so that weatherization professionals clearly understand the materials and procedures necessary to complete the job.
- ✓ Ensure all weatherization materials comply Appendix A.
- ✓ Estimate the cost of the materials and labor.
- ✓ Ensure a work scope is generated from the software measures report.
- ✓ Inform crews of any hazards, pending repairs, and important procedures related to the work order.
- ✓ Specify interim inspection when required by policy
- ✓ Ensure HVAC and SHELL professionals know who is the assigned project leader or contact person for each job.

2.4 QUALITY CONTROL INSPECTIONS

Refer to NREL QCI JTA; OSHA, EPA, BPI, IHCD, SWS, and AHJ

The quality control inspector (QCI) is responsible for the quality control of the weatherization project. The Building Performance Institute (BPI) credentials QCIs to perform inspections.

Quality control inspectors should be experienced and they must be familiar with Code, SWS, BPI, EPA, OSHA, IHCD and all other applicable guidance.

2.4.1 In-Progress Inspections

QCIs are encouraged to inspect jobs while the job is in progress when possible. This aids the QCI to capture missed opportunities or non-compliance with SWS, code, etc prior to the job completion. In-progress inspection also increases the rates of the job passing the final QCI inspection the first time, thus decreasing the length of time from audit to passed completion.

These measures are good candidates for in-progress inspections.:

- Dense-pack wall insulation
- Attic air sealing
- Insulating closed roof cavities
- Heating system installation or tune-up
- Duct testing and sealing
- Lead-safe work practices

2.4.2 Quality Control Inspection

All units must have a quality control inspection in order for the unit to be reported by the sub-grantee to the grantee as a completion. 100% of all units, including multifamily units must be inspected per IHCD Policy.

Energy-Audit Quality Control

A quality work order is important for the overall quality of the job. Some of the key points in evaluating the energy audit include, but are not limited to the following:

- Did the auditor find all the ECM opportunities?
- Did the auditor identify all the health and safety concerns and worker safety hazards?
- Do the audit ECMs comply with the energy model?
- Were measured skipped?
- Were measurements and material quantities accurate?

Work-Order Quality Control

When quality control inspector completes the final inspection with the crew on site, it can help crews correct deficiencies without returning to the home later. Ask these questions during the inspection:

- Did the work order adequately specify the labor and materials required by the energy audit?
- Did the crew follow the work order?
- What changes did the crew leader make to the work order? Were these changes appropriate?
- Are the completed weatherization job, the energy audit, and the work order aligned with State policy, DOE policy, and the SWS?

Verify the following during the quality control inspection.

- ✓ Confirm the crew installed the approved materials in a safely, effectively , and with quality workmanship.
- ✓ Confirm that the crew matched existing finish materials for measure installation and necessary repairs.
- ✓ Review all completed work with the client and provide client education.
- ✓ Verify that combustion appliances operate safely.
- ✓ Verify all mechanical systems pass appropriate testing.
- ✓ Complete a final blower door test with pressure diagnostics.
- ✓ Use an infrared scanner to inspect insulation and air-sealing effectiveness.
- ✓ Specify corrective actions when the work doesn't meet standards.
- ✓ Verify the crew used the correct lead-safe procedures.
- ✓ Verify all required paperwork with required signatures are in the client file.
- ✓ It is the responsibility of the Quality Control Inspector to complete a thorough inspection. They must inspect comprehensively so that they are able identify all failed tasks during the first inspection of the unit.
- ✓ It is best practice to separate failed tasks into two separate groupings: (1) failed tasks on work order and (2) missed opportunities that did not make in onto the work order.
- ✓ The Program Manager may assign additional responsibilities to the quality control inspector.
- ✓ Quality control inspectors should provide meaningful photographs of all failed tasks.

2.5 GRANTEE (IHCDA) MONITORING of SUBGRANTEES

Quality control is an internal process of a weatherization service provider (subgrantee) focusing on the final inspection.

Quality assurance is a third-party inspection performed by a monitor employed by the Grantee. Refer to IHCDA Weatherization Policy and Procedure Manual for details on the monitoring process.

2.6 DOE Monitoring of Grantees (States)

The DOE monitors the Grantees based on their State Plan and associated Health & Safety Plan. The DOE Project Officer's (PO's) job is similar to the agency's QCI. The PO is a DOE employee and reports the monitoring results to the State Grantee and the DOE but not the Subgrantee.

2.7 UNDERSTANDING ENERGY USAGE

SWS: 5.04 Solar Gain Reduction; 5.0401 Landscaping; 5.0401.1 Indigenous Shading; 6.02 Local Ventilation; 6.03 Whole Building Ventilation; 7.01 Plug Load(see all); 7.02 Water Conservation(see all)

A major purpose of any energy audit is to determine where energy waste occurs. A solid understanding of how homes use energy should guide the decision-making process.

Energy use should be a topic of client education in all units.

Table 2-1: Top Six Energy Uses for U.S. households

Energy User	Annual kWh	Annual Therms
Heating	2000–10,000	200–1100
Cooling	600–7000	n/a
Water Heating	2000–7000	150–450
Refrigerator	500–2500	n/a
Lighting	500–2000	n/a
Clothes Dryer	500–1500	n/a

Estimates by the authors from a variety of sources.

2.7.1 Baseload Versus Seasonal Use

We divide home energy usage into two categories: baseload and seasonal. Baseload includes water heating, lighting, refrigerator, and other appliances used year round.

Seasonal energy use includes heating and cooling.

Total energy use relates directly to potential energy savings. The greatest savings are possible in homes with highest initial consumption.

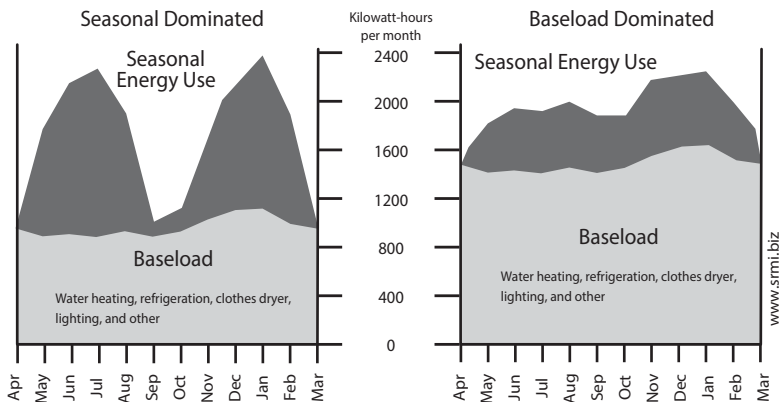

Seasonal vs. Baseload Domination of Energy Use: Homes with inefficient shells or in severe climates have large seasonal energy use and smaller baseload. More efficient homes and homes in mild climates are dominated by baseload energy uses.

Separating Baseload and Seasonal Energy Uses

To separate baseload from seasonal energy consumption for a home with monthly gas and electric billing, do these steps.

1. Get the energy billing for one full year. If the client can't produce these bills, they can request a summary from their utility company.
2. Add the 3 lowest bills together.
3. Divide that total by 3.
4. Multiply this three month average by 12. This is the approximate annual base load energy cost.

5. Total all 12 monthly billings.
6. Subtract the annual base load cost from the total billings. This remainder is the space heating and cooling cost.
7. Heating is separated from cooling by looking at the months where the energy is used — summer for cooling, winter for heating.

YOUR NOTES:

Table 2-2: Separating Baseload from Seasonal Energy Use

Factor and Calculation	Result
Annual total gas usage from utility bills	1087 therms
Monthly average gas usage for water heating Average of 3 low months gas usage $(21 + 21 + 22) \div 3 = 21.3$ therms per month	21.3 therms per month
Annual gas usage for water heating Monthly average usage multiplied by 12 $12 \times 21.3 = 256$ therms per year	256 therms per year
Annual heating gas usage Annual total minus annual water-heating usage $1087 - 256 = 831$ therms per year	831 therms per year
Annual total electric use from utility bills	6944 kWh
Monthly average usage for electric baseload Average of 3 low months electricity usage $(375 + 372 + 345) \div 3 = 364$ kWh per month	364 kWh per month
Annual electric usage for baseload Monthly average usage multiplied by 12 $12 \times 364 = 4368$ kWh per year	4368 kWh per year
Annual heating and cooling electrical usage Annual total minus annual baseload usage $6944 - 4368 = 2576$ kWh per year	2576 kWh per year

2.7.2 Energy Indexes (Home Heating Index-HHI)

Energy indexes are useful for comparing homes and characterizing their energy efficiency. They are used to measure the opportunity for energy savings.

Most indexes are based on the square footage of conditioned floor space. The simplest indexes divide a home’s energy use in

either kilowatt-hours or British thermal units (BTUs) by the square footage of floor space.

A more complex index compares heating energy use with the climate's severity. BTUs of heating energy are divided by both square feet and heating degree days to calculate this index. This more complex energy index which calculates the BTUs/square foot/heating degree day can be used to evaluate the potential for energy savings as a useful tool for choosing homes for weatherization services. Homes with high seasonal loads will offer greater potential for savings than homes that are already fairly efficient. See: <http://intelligentweatherization.org/billing-analysis-tools/>

2.8 CLIENT EDUCATION

Client education is a potent energy conservation measure. All clients must receive client education during each phase of weatherization. Pre-audit inspectors, energy auditors, crew leaders, HVAC professionals, and quality control inspectors each must provide education to the client(s).

Client education must include requirements as cited in DOE WPN-17 as well as any requirements outlined in the SWS or Grantee Policy.

CHAPTER 3: WEATHERIZATION MATERIALS

This chapter focuses on materials for insulation and air sealing.

3.1 AIR-SEALING GOALS

Refer to IHEDA Blower Door Guidance

Perform air leakage testing and evaluation before beginning air sealing or duct sealing work. Always evaluate ventilation and perform combustion safety testing as a part of air sealing a building.

Reducing air leakage accomplishes several goals.

- Saves energy by reducing unintentional air exchange with outdoors
- Reduces air leakage and convection around insulation, protecting its thermal resistance
- Enhances comfort by minimizing drafts
- Minimizes moisture migration into building cavities
- Aid in minimizing pollutants into the living space
- Reduces the pathways where fire can propagate through a building

YOUR NOTES:

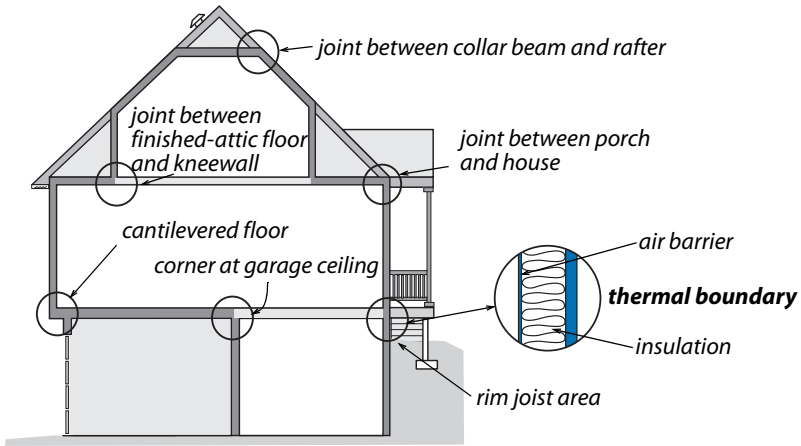

Air leaks at the thermal boundary: The air barrier and insulation must be in contact with one another. The insulation and the air barrier are often discontinuous at corners and transitions.

3.2 AIR SEALING SAFETY

Refer to OSHA, NIOSH, and ESR report(foam)

Air sealing reduces the exchange of fresh air in the home, and can alter the pressures within the home. Before air sealing, survey the home to identify both air pollutants that may be concentrated by air sealing efforts and open combustion appliances that may be affected by changes in house pressure.

Do not air seal until deferral and mechanical work is completed.

3.2.1 Air Sealing and Fire Containment

SWS Detail: 3.01 General Pressure Boundary; 3.0102 Specific Air sealing; 3.0105 Attached garage; 2.03 Electrical

Fire, flame, and smoke spread through the paths of least resistance. Many building assemblies harbor concealed voids or cavities within walls, ceilings, and attics.

The building codes define a fire block as a material installed to “resist the free passage of flame through concealed spaces.” Fire-blocking materials need not be non-combustible.

Consider rigid fire-blocking materials such as the following ones suggested below from the IRC. Also, refer to the SWS and other applicable codes.

- Plywood, OSB or other wood sheeting ($\frac{3}{4}$ inch thick)
- Drywall ($\frac{1}{2}$ or $\frac{5}{8}$ inch thick)
- Mortar, reinforcing material, and compatible non-combustible caulking to air-seal masonry building assemblies.

3.3 AIR SEALING MATERIALS

Refer to Appendix A; SWS 3.01 General Pressure Boundary

Air barriers prevent movement of air from one space to another.

Use caulk by itself for sealing small cracks. Use liquid foam for cracks larger than $\frac{1}{4}$ inch. Any hole/crack which is larger than 3" in any one direction requires backing or infill as a first step in airsealing.

3.3.1 Air-Barrier Materials

Plywood, OSB, etc.

Three-quarter-inch plywood, OSB, and particle board are IRC-approved fire-blocking materials. Attach the structural sheets with screws or nails along with any sealant or adhesive that effectively air seals the joint.

Drywall

Half-inch drywall constitutes a 15 minute thermal barrier and is an ignition barrier. When air sealing a fire-rated assembly in a multifamily buildings and garages, choose five-eighths -inch drywall and a fire-rated caulking. Fasten drywall with screws and construction adhesive.

Steel and Aluminum Sheet Metal

Installers use noncombustible sheet metal to seal around chimneys and other heat producing components. To seal around chimneys, cut the sheet metal accurately so that you can seal the gap with high temperature, non combustible caulk labeled ASTM E136.

Foam Board

Foam board may be a desirable product for air sealing; however it has less structural strength and fire resistance than the other materials. You must consult the ESR report for proper location of foam board installation.

Cross-Linked Polyethylene House Wrap

House wrap and polyethylene sheeting are air barriers. These flexible materials aren't rated as fire-blocks, and they are structurally weak.

3.3.2 Backing Materials

Backing materials are used to fill a cavity, to give the cavity a bottom, or to serve as supporting part of air sealing.

Backer Rod

Backer rod is closed-cell polyethylene foam that creates a bottom barrier in a gap before caulking.

Fiberglass Batts

Fiberglass batts are air permeable. Batts can support two-part foam sprayed over the opening of a cavity.

Blown Cellulose and Blown Fiberglass

Blown cellulose and fiberglass reduce air convection and air leakage. Neither material is an air barrier even when blown at high densities. Both are considered fire-blocks when installed in closed cavities because they block the passage of flames.

3.3.3 Caulking and Adhesives

The adhesion and durability of caulking and adhesives depends on their formulation and on the surfaces to which they're applied. Some caulks and adhesives are sensitive to dirt and only work well on particular surfaces, while others are versatile and dirt-tolerant. Remove debris and clean the joint to prepare the surfaces for caulking. Don't get it in your hair or beard.

Water-Based Caulks

A wide variety of paintable caulks are sold under the description of acrylic latex and vinyl. Don't apply water-based caulks to building exteriors when rain is forecast since they aren't waterproof until cured, and they stain nearby materials if they are rained upon while curing. Do not apply water based caulks during freezing weather.

Silicone Caulk

Silicone has great flexibility, but its adhesion varies among different surfaces. Silicone is easy to gun even in cold weather. Most silicone is not paint-able, so choose an appropriate color. High temperature silicone may be used with metal flashing to air seal around chimneys if labeled ASTM E136.

Polyurethane Caulk

Polyurethane has the best adhesion and elasticity of any common caulk. It works well for cracks between different materials like brick and wood. Polyurethane resists abrasion. It is used to seal critical joints in concrete slabs and walls. Cleaning up is difficult. Polyurethane caulk should be room temperature or higher.

Water Soluble Duct Mastic

The best material for sealing ducts, including cavities used for returns ducts is mastic. Use mastic and fiberglass web tape to reinforce cracks/holes more than 1/8" in diameter.

Stove Cement

Stove cement can withstand temperatures of up to 2000 degrees F.

It can be used to seal wood stove chimneys and to cement wood stove door gaskets in place.

Non-Combustible Caulk

Some elastomeric caulks are designed specifically for use in fire-rated assemblies. They are labeled ASTM E136. Use this type of sealant when sealing penetrations through fire-rated assemblies in multifamily buildings.

Fire-Rated Mortar

Used with other air-sealing materials to seal various sized holes and gaps in multifamily buildings with fire-rated masonry building assemblies. This mortar often covers a foam air sealant to create a non-combustible surface for a combustible air seal.

Construction Adhesives

Construction adhesives are designed to bond materials together. They create an air seal if applied continuously around the perimeter of a rigid material. They are often used with fasteners like screws or nails but can also be used by themselves. Use specially designed construction adhesives for polystyrene foam insulation because many general purpose adhesives decompose the foam's surface.

3.3.4 Polyurethane Foam Air Sealant

Liquid closed-cell polyurethane foam is a versatile air sealing material. It is also an insulation material. Closed-cell foam is packaged in a one-part and two-part options. It has a high R-value per inch and is ideal for insulating and air sealing. Follow manufacturer's guidance when installing. Follow each foam brand ERS report guidance.

One-Part Foam

One-part foam is not effective or easy to apply to gaps over about three inches or to bottomless gaps.

Two-Part Foam

Known as spray polyurethane foam (SPF), this product is good for bridging gaps larger than one inch and is available in a vari-



One-part foam: A contractor uses an applicator gun to seal spaces between framing members and around windows.



Two-part foam: A contractor air-seals and insulates around an attic hatch dam with two-part spray foam.

ety of densities. Two-part foam is popular for use with rigid patching materials to seal large openings. . Two-part foam should be sprayed to the manufacturer's recommended thickness. Two-part foam should not be used for sealing poly moisture barriers. Foam Construction Adhesive

Polyurethane adhesive foam dispensed from foam guns is an excellent adhesive for joining many kinds of building materials. It works well for joining foam sheets together into thick slabs for vertical access doors and attic hatches.

3.4 INSULATION BUILDING SCIENCE

Insulation reduces heat transmission by resisting the conduction, convection, and radiation of heat through the building. Insulation combined with an air barrier creates the thermal envelope between the conditioned indoors and outdoors.

Installing insulation is one of the most effective energy-saving measures. You can ensure insulation's safety and effectiveness by following these guidelines.

- ✓ Install insulation in a way that enhances fire safety and doesn't degrade it.
- ✓ Comply with lead-safe practices when applicable.
- ✓ Prevent air movement through/around the insulation with an effective air barrier. Ensure the air barrier and insulation are aligned.
- ✓ Protect insulation from moisture by repairing roof and siding leaks, providing site drainage, and by controlling vapor sources within the home.
- ✓ Install insulation to meet or exceed the guidelines of the International Energy Conservation Code (IECC) and SWS

Insulation Certificate

Provide each client receiving insulation products and services, a printed and signed certificate that includes the following:

- Insulation type
- Coverage area
- Number of bags installed
- R-value
- Installed thickness and settled thickness
- Amount of insulation installed according to manufacturer's specifications
- Include an ICC_ES report when installing spray foam insulation

3.5 INSULATION MATERIAL CHARACTERISTICS

The purpose of insulation is to provide thermal resistance that reduces the rate of heat transmission through building assemblies.

3.5.1 Fibrous Insulation Materials

If blown at a high density, fibrous insulations aren't air barriers themselves, but they may contribute to the air-flow resistance of a building assembly. The term *mineral wool* describes both fiberglass and *rock wool*. Rock wool is both a generic term and a trade name. We use rock wool in the generic sense as an insulating wool spun from rocks or slag. Fiberglass is wool spun from molten glass.

Cellulose is manufactured primarily from recycled paper, treated with a fire retardant.

A vapor permeable air barrier should cover fibrous insulation installed vertically or horizontally in human-contact areas to limit exposure to fibers.

Fiberglass Batts and Blankets

Most fiberglass batts are available in a variety of width and thickness..

R-values of batts vary from 3.1 per inch to 4.2 per inch. Installed fiberglass R values are dependent on the quality of workmanship when installed.

Installers must cut and fit batts very carefully. Batts achieve their advertised R-value only when they are installed properly. Although fiberglass doesn't absorb much moisture, the facings on blankets and batts can trap water which can dampen building materials and provide a water source for pests.

Evaluating batt performance: The thermal performance of batts depends on density and installation.

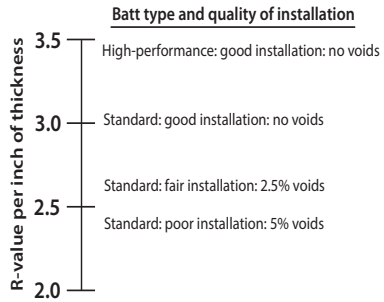

Facings for Fiberglass Batts

Insulation manufacturers make batts and blankets with a number of facings, including the following:

- Unfaced: Vapor permeable and Class-A fire rating of ≤ 25 flame spread.
- Kraft paper: A Class II vapor retarder that is flammable (Class-C or Class 3) with a flame spread ≥ 150 .
- Foil-kraft: foil bonded to kraft paper. A vapor barrier with a flame spread of >75 (Class-C or Class 3).
- Foil-skrim-kraft (FSK): Aluminum foil bonded to kraft paper with skim netting in-between as reinforcement. A vapor barrier available as a Class-A material with a flame spread of ≤ 25 .
- White poly-skrim-kraft (PSK): White polyvinylchloride bonded to kraft paper with skim netting in-between as reinforcement. A vapor barrier available as a Class A fire-rated material with a flame spread of ≤ 25 . The white surface maximizes light reflection.

Blown Fiberglass

Loose fiberglass is blown in attics from 0.3 to 0.8 pcf and at that density range, the R-value is around 2.9 per inch.

Fiberglass manufacturers now provide two blowing products, one for standard densities of up to about 1.4 pcf, and another for dense-packing to more than 2.0 pcf.

In closed cavities, installers blow fiberglass to manufacturer's recommended density. The high density fiberglass is typically reserved for walls where the superior resistance to settling, airflow, and convection has extra value over lesser density.

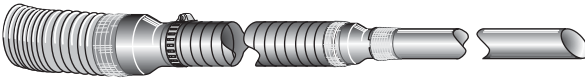

Insulation hoses, fittings, and the fill tube: Smooth, gradual transitions are important to the free flow of insulation.

Blown Cellulose

Loose cellulose is blown in attics to manufacturer's recommended densities and at that density range, the R-value is around 3.7 per inch. Utilize manufacturer's coverage chart to account for settling.

Cellulose treated with ammonium sulfate should not be installed when it will be in contact with metal.

In wall cavities, cellulose is blown at a higher density of between 3.5 to 4.0 pcf, to prevent settling and to maximize its airflow resistance. At that high density, cellulose's R-value per inch is around 3.4. Evaluate the strength of wall cladding before blowing a wall with cellulose to prevent damage during.

Cellulose absorbs up to 130% of its own weight in water. Before anyone discovers a moisture problem, the cellulose could be soaked, shrunken, double its dry weight, and far less thermally resistant. Cellulose shouldn't be installed in the following places .

- Horizontal or cathedral closed roof cavities
- Floor cavities above unconditioned crawl spaces or unconditioned basements
- Mobile homes
- Below grade walls

Rock Wool

Rock wool is a type of mineral wool like fiberglass.

Rock wool is the most moisture-resistant insulation discussed here. In rainy and humid climates, rock wool is the least likely insulation to harbor moisture or support pests.

Damp Spray Fibrous Insulation

Installers mix fibrous insulation with sprayed water and a small amount of adhesive in damp-spray applications either in open cavities or directly adhered to building surfaces.

3.5.2 Operating the Insulation Blowing Machines

SWS: Section 4 Insulation: Installation

Perform these important steps before and during insulation-blowing.

- ✓ Verify that the electrical source can provide the ampere draw of the insulation machine.
- ✓ Measure the pressure created by a blowing machine by connecting the hose to a fitting attached to a manometer. Close the feed gate and turn the air to the highest setting. For cellulose, the blowing machine should develop 2.9 pounds per square inch (psi) or 80 inches of water (IWC) For other types of fibrous insulation, check manufacturer specifications for blowing machine set up.
- ✓ Verify that you're blowing the correct density of fibrous insulation by using the bag's weight or the manufacturer's coverage tables.

Important Note: Dense-packed fibrous insulation can reduce air leakage and convection in closed building cavities. However, don't use dense-packed fibrous as a substitute for the air sealing techniques described throughout this guide.

Blower pressure gauge: For blowing closed cavities, blower pressure should be at least 80 IWC or 2.9 psi. Measure the pressure with maximum air, feed gate closed, and agitator on.



3.5.3 Spray Foam Insulation Materials

Refer to OSHA, IHCDA, and Occupant Health Screening

Spray Polyurethane Foam SPF is combustible and creates toxic smoke. Foam insulation usually requires covering with a thermal barrier or an ignition barrier. SPF comes in two formulations: closed-cell and open-cell.

Spray foam is an insect-friendly material that can aid termites and carpenter ants in establishing a colony in wood structures. Mitigate all sources of ground water before installing foam near a foundation. When foam is installed on the outside of foundations, the surrounding soil should be treated with a termiticide. Inside a crawl space, foam must never provide a direct link from the ground to wood materials. The International Residential Code (IRC) forbids foam below grade in “very heavy” termite-colonized areas.

Caution: Two-part foam is hazardous to installers and building occupants. Installers must wear special personal protective equipment and ventilate spaces during installation to avoid ung, skin, and eye damage. SPF can harm occupants who breathe the toxic vapors during installation. SPF requires precise mixing of the two components at specific temperature ranges. Improperly mixed or installed spray foam can emit vapors for months or years resulting in long-term respiratory hazards.

Closed-Cell Spray Polyurethane Foam

Closed-cell polyurethane spray foam (SPF) is an air barrier and a vapor barrier and is expensive. Closed-cell SPF is a good value when space is limited, where an air or vapor retarder is needed, or where its structural strength and durability are needed.

Spray foam professionals install closed-cell SPF from two 55-gallon containers through hoses and a nozzle that mix the material. The closed-cell foam installs at approximately 2 pcf density and achieves an R-value of 6 or more per inch. Closed-cell polyurethane foam is also packaged in smaller containers in the following products.

- One-part high-expanding foam for air sealing.
- One-part low-expanding foam for air sealing.
- Two-part high-expanding foam for air sealing and insulation of surfaces.

Open-Cell Polyurethane Spray Foam and Injectable Foam

Polyurethane open-cell foam is installed at between 0.5 pcf to 1.0 pcf and achieves an R-value of around 3.7 per inch to 4.7 per inch depending on density.

These open-cell formulations are injected into a hole, one inch or smaller, through an injection nozzle. The open-cell foam can subject a wall cavity to some excess pressure, so evaluate wall-cladding strength before injecting it.

Open-cell foam can absorb both water vapor and liquid water. Open-cell foam can hold moisture and become a medium for mold growth. We recommend that contractors don't install low-density spray foam in the following locations:

- Underside of roof decking
- Underside of floor decking above crawl spaces
- Crawl space walls

3.5.4 Special Safety Precautions for Spray Foam

Two-part foam is hazardous to installers and building occupants. SPF can harm occupants who breathe the toxic vapors during installation. SPF requires precise mixing of the two components at specific temperature ranges. Improperly mixed or installed spray foam can emit vapors for months or years resulting in long-term respiratory hazards.

Installers must wear special personal protective equipment and ventilate spaces during installation to avoid lung, skin, and eye damage. Evacuate the area of other workers not wearing appropriate respiratory protection.

Consider essential these precautions for spraying foam safely.

1. Ask the occupants to leave while you spray foam for as long as a day. Power ventilate the area during installation and for at least 24 hours afterwards.
2. When spraying low-pressure polyurethane foam — either 1-part or 2-part — use a respirator cartridge designed to filter organic vapors, and ventilate the area where you're spraying the foam.
3. You must complete training, including safety training, before spraying high-pressure 2-part foam.
4. When spraying high-pressure polyurethane foam from a truck-mounted machine, use a supplied-air, positive-pressure respirator, and ventilate the area.

3.5.5 Fire Protection for Foam Insulation

Refer to ESR report

Plastic foam is the generic term used by the IRC for both rigid and spray foams. Plastic foams are combustible and create toxic smoke when they burn.

The following fire-safety and durability issues are particularly important to installing foam insulation.

- You must refer to the ESR report for each specific brand of foam for installation requirements.
- You must leave a copy of the ESR report used for each job attached to a copy of the Certificate of Insulation.
- A *thermal barrier* is a material, usually drywall, that protects combustible materials behind it from heat and flame creating a fire.
- An *ignition barrier* is designed to delay the ignition of the material it protects. Ignition barriers include plywood, galvanized steel, damp-spray mineral wool, and intumescent paint. Intumescent paint is a proprietary latex coating designed to delay the ignition of foam insulation in a fire.

The IRC requires a thermal barrier (half-inch drywall) for spray foam in all living areas and storage areas.

3.5.6 Foam Board Insulation

Foam board is combustible and creates toxic smoke if it burns. Refer to the ESR report for proper installation.

Foam board is an insect-friendly material that can aid termites in establishing colonies. Mitigate all sources of ground water before installing foam near a foundation. When foam is installed on the outside of foundations, the surrounding soil should be treated with a termiticide. Inside a crawl space, foam must never provide a direct link from the ground to wood materials where termites or carpenter ants are common. The IRC forbids foam below grade in “very heavy” termite-colonized regions; the foam must be kept 6 inches above grade.

Expanded Polystyrene (EPS) Foam Board

EPS foam board is sometimes called beadboard, EPS varies in density from 1 to 2 pcf with R-values per inch of 3.9 to 4.7, increasing with greater density. EPS is packaged in a wide variety of products by local manufacturers. Products include structural insulated panels

(SIPS), tapered flat-roof insulation, EPS bonded to drywall, and EPS embedded with fastening strips.

EPS is flammable and produces toxic smoke when burned. It has a low maximum operating temperature (160 degrees F) that is a concern for using EPS under dark-colored roofing or siding. EPS has shrunken in some installations.

EPS is very moisture resistant and its vapor permeability is similar to masonry materials, which makes EPS a good insulation for masonry walls.

Dense EPS (2 pcf) is appropriate for use on flat roofs and below grade. Dense EPS is also more dimensionally stable and less likely to shrink. Use weatherproof coverings to prevent degradation by ultraviolet light and freezing and thawing at ground level.

Extruded Polystyrene (XPS) Foam Board

XPS is rated for below-grade applications. XPS has a higher R value than EPS and is the most moisture-resistant foam board.

XPS is flammable and produces toxic smoke when burned. XPS must be covered by a thermal barrier when installed in living spaces. XPS has a low maximum operating temperature (160 degrees F) that is a concern for using XPS under shingles or dark-colored siding. XPS has shrunken in some installations. Use weatherproof coverings to prevent degradation by ultraviolet light and freezing and thawing at ground level.

Polyisocyanurate (PIC) Foam Board

PIC board has the highest R-value per inch of any common foam board. PIC is packaged with a vapor permeable facing or an aluminum-foil (vapor barrier) facing.

PIC is combustible and produces toxic smoke during a fire. However some products have fire retardants that allow installation in attics and crawl spaces without a thermal barrier or ignition barrier.

PIC has a low maximum operating temperature (<200 degrees F) that may be a concern for using PIC under dark-colored roofing or siding. Use the high-density (3 pcf) PIC board for low-sloping roof insulation.

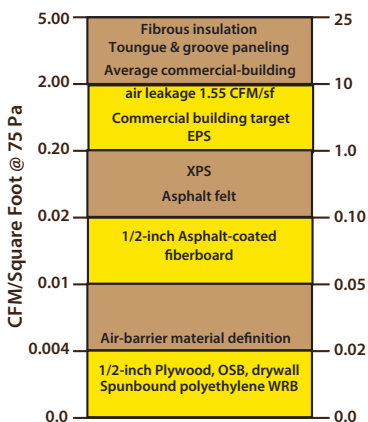

Air Permeability of Materials and Assemblies

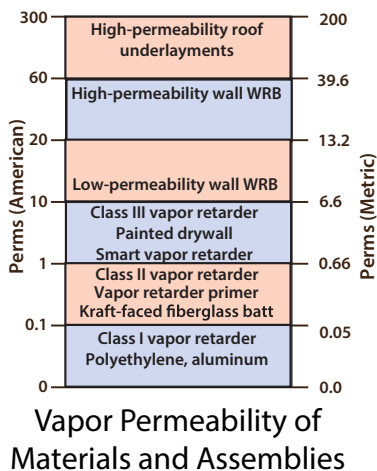

3.6 INSULATION DURABILITY

Moisture is the most common durability problem in insulated building assemblies. Entrained moisture reduces the thermal resistance of many insulation materials.

Moisture prevention includes denying moisture access to building cavities, allowing condensed water to drain out, and allowing moisture to dry.

Retrofitting insulation can affect the preventive measures listed here. Consider the function and relevance of these building components when you install insulation.

- Air barrier:** Air can carry moisture into building cavities from indoors or outdoors where the moisture can condense and dampen insulation and other building materials. Air leakage is an energy problem too. The air barrier is any continuous material or building assembly that provides acceptable resistance to air leakage.

- **Vapor retarder:** Vapor diffusion can carry large amounts of water vapor into building cavities where it can condense and dampen insulation and building materials. They resist water vapor diffusion from indoors into cavities where condensation can dampen insulation and building materials.
- **Vapor barrier:** A very effective vapor retarder. A vapor retarder with a perm rating of less than 0.1 perms.
- **Ground-moisture barrier:** The ground under a building is the most potent source of moisture in many buildings, especially those built on crawl spaces. Crawl spaces require ground-moisture barriers.
- **Water-resistive barrier (WRB):** Asphalt paper or house wrap, under siding and roofing, serves as the home's last defense to wind-driven rain.
- **Vapor permeable materials:** Most common building materials are permeable to water vapor, which allows the water vapor to follow a gradient from wet to dry.
- **Flashings:** Seams and penetrations in building assemblies are protected by flashings, which prevent water from entering these vulnerable areas.
- **Drainage features:** Intentional or unintentional drainage features of buildings allow water to drain out of cavities. Examples: Masonry veneers have intentional drainage planes and weep openings near their bottoms. Cathedral ceilings drain water out through their soffit vents unintentionally.
- **Water storage:** Masonry veneers and structural masonry walls have the ability to store rainwater and dry out during dry weather.
- **Ventilation:** Roofs, attics, crawl spaces and even some walls have ventilation features that dry out wet building assemblies.
- **Termiticide:** When foam insulation is installed below grade in regions with termites, apply a termiticide to the soil in amounts determined by the labeling of the termiticide.

CHAPTER 4: ATTICS AND ROOFS

This chapter discusses air sealing and insulating attics and roofs. The air barrier and the insulation should be adjacent to one another and continuous at that location.

4.1 AIR-SEALING ATTICS AND ROOFS

SWS Detail: S3.0102 Specific air sealing; 3.0103 Intentional attic opening

Air sealing attics and roofs may be the most important and cost effective weatherization measure. The attic or roof is a prominent location for air leakage and moisture damage.

4.1.1 Sealing Vertical Chases

SWS Detail: 3.0101 General air sealing; 3.0101.1 Air sealing holes; 3.0102 Specific air sealing

Observe the following when sealing vertical chases.

- ✓ Inspect the chase for damage and pest infestation.
- ✓ Span the entire opening with a rigid material.
- ✓ Use supporting material for spans more than 24 inches as necessary.
- ✓ Seal joints at the perimeter and seams with a compatible sealant.

Sealing around Manufactured Chimneys

SWS Detail: 3.0102.2 Sealing high temperature devices

Several types of manufactured chimneys are common in residential buildings.

- ✓ Remove existing insulation from around the manufactured chimney.
- ✓ Cut sheet metal in two pieces with half-circle holes for the chimney that create small caulk-able cracks.
- ✓ Bed the metal in sealant and staple, nail, or screw the metal in place.
- ✓ Caulk around the junction of the chimney and the metal and air seal with non-combustible caulk labeled ASTM E136.
- ✓ Cut and assemble a metal insulation shield that creates a 3-inch space between the shield and chimney and extends above the planned level of the insulation.

See photo on next page



Sealing manufactured chimneys: When installing retrofit insulation in addition to air sealing, install a shield on top of the air seal that extends above the level of the new insulation.

Sealing around Masonry Chimneys

Leaks around fireplace chimneys are often severe air leaks. Use this procedure to seal air leaks through the chimney chase.

- ✓ Cut sheet metal to fit the gap that borders the chimney with overlaps connecting to nearby attic framing lumber.
- ✓ Bed the sheet metal in sealant and fasten the sheet metal to the attic framing with staples, nails, or screws.
- ✓ Seal the metal patch to chimney with a non-combustible sealant labeled ASTM E136.
- ✓ Seal other gaps between the attic and the chimney chase.
- ✓ For large chimney chases, cover the chase opening with structural material. Maintain clearances between the structural seal and the metal or masonry chimney

Sealing around chimneys: Chimneys require both an air seal and a shield if retrofit insulation is installed with air sealing.

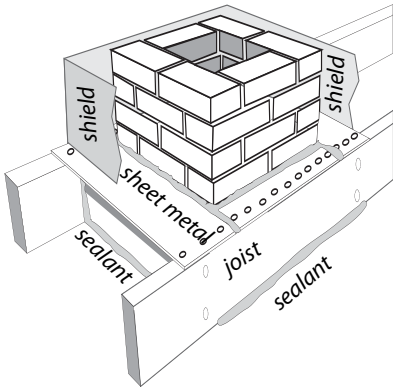

4.1.2 Air Sealing Recessed Lights

SWS Details: 3.0102.1 Sealing non-insulation contact recessed light; 3.0102.9 Sealing dropped soffits/bulkheads

The most common type of recessed light fixture is the round can. All recessed light fixtures are potential air leaks. Many recessed light fixtures have safety switches that turn them off at around 150° F. Too much insulation covering the fixture or foam insulation could cause the safety switch to cycle.

Types of Recessed Can Lights

There are three kinds of recessed can lights found in buildings with regard to their need for insulation shielding. (IC means insulation contact. AT means airtight.)

1. Older cans that aren't rated for contact with insulation, known as non-IC-rated cans.

2. IC-rated cans that may be covered with fibrous insulation but not foam insulation.
3. ICAT-rated cans that are airtight in addition to being rated for insulation contact.

Options for Sealing Non-IC-Rated Fixtures

Consider these three options for air sealing recessed can lights. You can enclose the existing fixture, replace it with an ICAT recessed fixture, or surface mount LED.

1. Build a Class I fire-resistant enclosure over the non-IC-rated fixture leaving at least 3 inches clearance from insulation on all sides and to the lid of the enclosure. Seal enclosure to surrounding materials with foam to create an airtight assembly. The top of this fire-resistant enclosure must have an R-value of 1.0 or less. Do not cover the top of the enclosure with insulation.
2. Replace the recessed fixture with a new ICAT fixture, and carefully seal around this airtight fixture.
3. Install an airtight LED-retrofit fixture. This fixture will hard wire into or cover the existing recessed fixture.

Caution: Do not cover IC-rated or airtight IC-rated fixtures with spray foam insulation. The foam's high R-value and continuous contact could overheat the fixture.

SEE PHOTOS NEXT PAGE

drywall box air seal

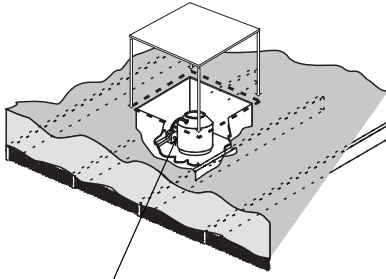

recessed light fixture

Airtight LED retrofit for can

lights: These retrofit fixtures provide a low-wattage LED with a low-air-leakage enclosure that inserts into the existing can light. These fixtures must hardwire into the existing fixture. They cannot simply be screwed in such as a with a lightbulb.

Air seal and shield for non-IC can:

This drywall box is an insulation shield and air seal, but allows the fixture some air circulation for cooling.

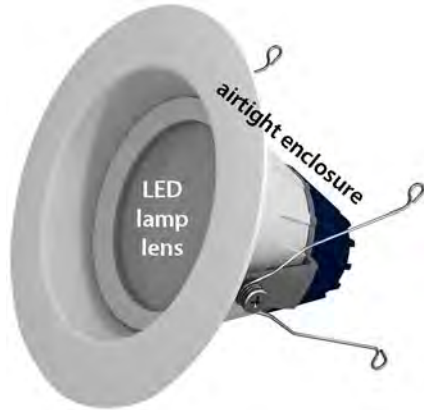

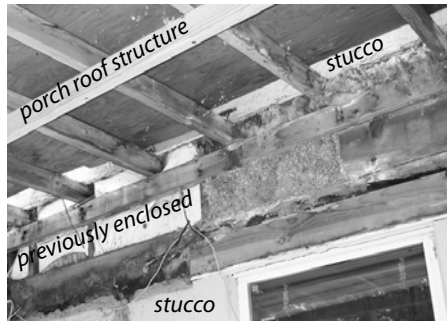
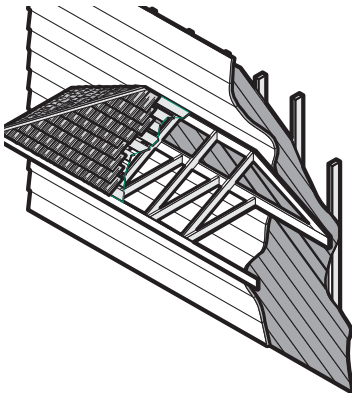

Porch air leakage: Porch roof cavities often allow substantial air leakage because of numerous joints, and because there may be no siding or sheathing installed in the wall behind the roof and ceiling.

4.1.3 Sealing Porch Roof Structures

SWS Detail: 4.0104 Attic Knee Walls

Porch roofs on older homes were often built at the framing stage or before the water resistive barrier (WRB) and siding were installed. The porch's roof sheathing, roofing, and tongue-and-groove ceiling aren't air barriers. The loosely fitting wall sheathing or unsheathed wall allows air into the wall cavities where it migrates into the conditioned space.

Consider these options for air-sealing a porch roof.

- • Remove part of the porch ceiling and install a rigid air barrier or cover the area with closed-cell spray foam.
- • Access can be made from the gable walls or through the roof of the porch.

4.1.4 Sealing Joist Cavities Under Knee Walls

SWS Detail: 3.0102 Specific air sealing; 4.0104 Attic Knee Walls

Floor joist cavities beneath knee walls allow air from a ventilated attic space to enter the floor cavity between stories.

Create an air seal between the knee wall and the ceiling of the space below using one of these methods.

- From the attic, install a combination of rigid foam with one-part or two-part foam sealing the perimeter.
- From the attic, stuff a fiberglass batt into the joist space and seal it with spray two-part foam from the attic.
- From the attic, install foam board on the attic side of the knee wall and continue it down to cover the joist space by cutting slots in the foam board for the joists. Seal around the joists and at the ceiling of the space below with spray foam.
- From indoors, cut the flooring back from the wall at the indoors and install the air seal and insulation under the knee wall.
- If knee attics are used for storage, check the foam board manufacturers ESR for code and fire compliance.

4.1.5 Sealing Kitchen or Bathroom Interior Soffits

SWS Detail: 3.0103.10 Sealing dropped ceilings; 3.0101 General air sealing; 3.0102 Specific air sealing

Many homes have soffits above kitchen cabinets and in bathrooms. Large rectangular passages link the attic with the soffit cavity. The air convects heat into or out of the conditioned space. Attic air infiltrates the conditioned space through openings in the soffit or associated framing.

- ✓ Seal the soffit with rigid blocking, bedded in sealant and fastened to ceiling joists and soffit framing with screws, nails or staples.
- ✓ Seal the patch's perimeter thoroughly with two-part foam or caulking.

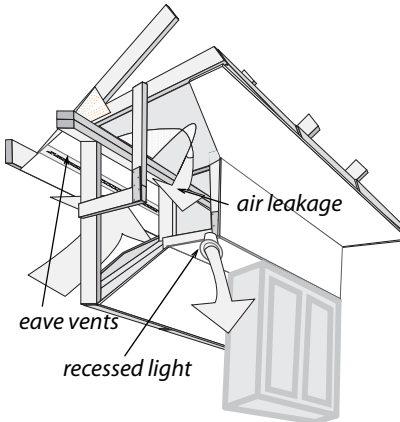

Kitchen soffits: The ventilated attic is connected to the soffit and the wall cavity through framing flaws. Any hole in the soffit creates a direct connection between the kitchen and attic. Block off the soffit from the attic with drywall or plywood sealed with two-part spray foam as shown in the photo.

4.1.6 Sealing Two-Level Attics

SWS Detail: 3.0102 Specific air sealing; 4.0104 Attic Knee Walls

Split-level and tri-level homes have a particular air leakage problem related to the walls and stairways dividing the homes' levels.

- ✓ Seal wall cavities below the ceiling joists from the attic with a rigid material fastened to studs and wall material.
- ✓ Or insert folded fiberglass batt into the wall cavity and spray with at least one inch of two-part foam to create a rigid air seal.

- ✓ Dense-pack the transitional wall or insulate it with fiber-glass batts. Either way install an air barrier on the attic side of the wall.
- ✓ Seal penetrations between attics and conditioned areas.

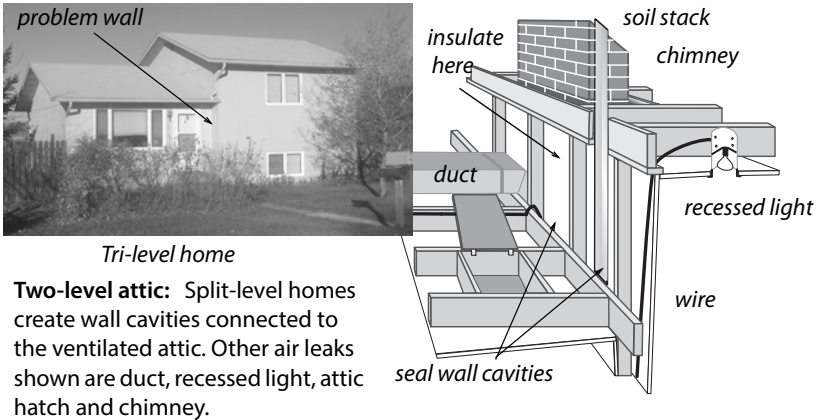

Two-level attic: Split-level homes create wall cavities connected to the ventilated attic. Other air leaks shown are duct, recessed light, attic hatch and chimney.

4.1.7 Sealing Dropped Ceilings

SWS Detail: 4.0104 Attic Knee Walls; 3.0102.9
Sealing dropped soffits/bulkheads

Suspended T-bar Ceilings

Suspended ceilings are not airtight. Suspended ceilings are not a good location for an air barrier.

Remove panels of a suspended ceiling to inspect. If there is a plaster ceiling above a non-structural suspended ceiling and it is failing, consider these options.

- ✓ If you install insulation on top of existing insulation above the failing ceiling make the original ceiling the air barrier.
- ✓ Reinforce the existing plaster.
- ✓ Screw drywall over missing plaster.
- ✓ Seal the ceiling's joints and perimeter with sealant.

An insulated roof deck above a non-structural suspended ceiling may be the only practical place to establish an air barrier.

- ✓ Air seal the roof/wall junction with sealant.
- ✓ Air seal the perimeter walls above the suspended ceiling and insulate them if they are exterior walls.
- ✓ Insulate the walls if necessary.

Structural Dropped Ceilings

Ceilings suspended using lumber or steel studs may be structural, however, evaluate the structure before walking on it.

- ✓ Seal and insulate the walls between the dropped ceiling and upper ceiling.
- ✓ Seal the ceiling joints, penetrations, and perimeter with sealant.
- ✓ Insulate, ensuring thermal and pressure boundaries are aligned.

YOUR NOTES:

4.2 INSULATING ATTICS AND ROOFS

Attic and roof insulation are two of the most cost effective energy conservation measures.

Buildings with sloping ceilings or flat roofs are usually insulated in the roof cavity. A majority of buildings have fibrous insulation in the attics or roof cavities. Attics and roof cavities need ventilation for drying, cooling, and to prevent ice dams.

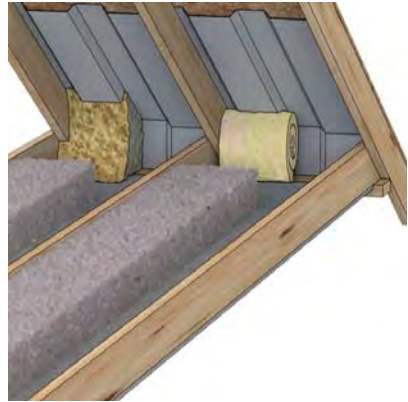
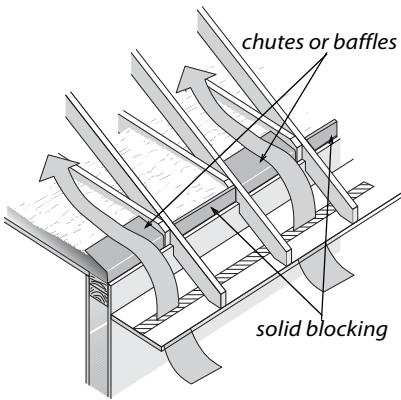

Ventilation pathways: Install chutes/baffles adjacent to existing attic ventilation.

Insulation at the eaves: Stuff fibrous insulation into the eave area to maximize R-value

4.2.1 Preparing for Attic Insulation

SWS Detail: 3.01 General Pressure Boundary; 4.01 Attics

Take these preparatory steps before insulating the attic.

- ✓ Repair roof leaks and remove moisture sources.
- ✓ Remove hazardous materials, contaminated insulation, and debris from the attic. Contract qualified professionals as necessary.
- ✓ Vent all kitchen and bath fans to the outdoors.
- ✓ Prevent insulation from filling eaves. Install baffles/chutes.
- ✓ Before insulating the attic, seal air leaks and bypasses.
- ✓ Verify attic air tightness
- ✓ Install an attic access hatch if none is present or if the location of the existing hatch does not allow for reasonable access. Newly installed attic hatch should be at least 22"x 30" per the IRC.
- ✓ Insulate the hatch to the maximum practical R-value up to the existing R-value of the surrounding components.
- ✓ Build an insulation dam around the attic access hatch two inches above the height of the insulation. Build the dam with rigid materials so that the dam supports the weight of a person.
- ✓ If head space is very limited at an interior hatch use fiber-glass batts to dam loose fill insulation.

YOUR NOTES:

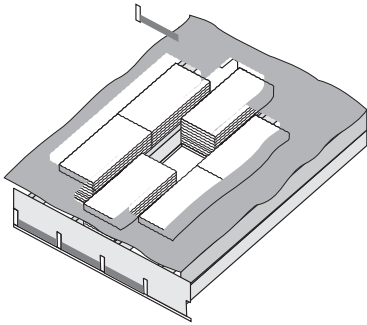

Batts form attic-insulation dam: Where head space is limited, fiberglass batts are a good choice for a low-profile insulation dam.

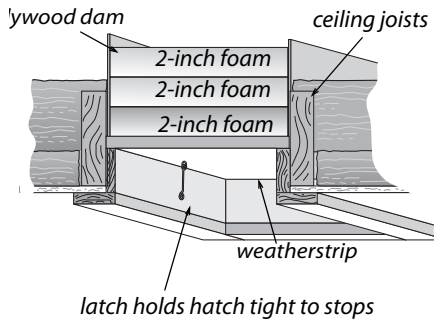

Insulated attic hatch: Building a dam prevents loose-fill insulation from falling down the hatchway. Foam insulation prevents the access hatch from being a thermal weakness. Install foam to achieve attic-insulation R-value of R-38. Foam can be glued together in layers.

4.2.2 Safety Preparations for Attic Insulation

SWS Detail: 2.0201 High voltage(50 volts or more);
 3.0102.1 Sealing non-insulation contact recessed light;
 3.0102.2 Sealing high temperature devices;
 3.0102.4 Sealing firewalls; 3.0103.4 Tenting of wet sprinkler systems;
 3.0103.3 Whole house fan-operable; 3.0105.1 Isolating garage from living space;
 Section 4-Insulation

Before insulating the attic, protect the heatp roducing fixtures. The shielding enclosure often serve as the air seal for the chimney or light fixture.

Electrical Junction Boxes

Observe these specifications during attic insulation preparation.

1. Install electrical junction box covers where missing.
2. Use caulk or foam to air seal electrical boxes that penetrate the ceiling.
3. Flag all electrical junction boxes.

Knob-and-Tube Wiring

SWS Detail: 2.0301.2 Knob and tube wiring--isolation

If knob-and-tube wiring is present, either decommission it or install insulation shielding.

4.2.3 Blowing Attic Insulation

SWS Detail: 4.0102.3 Inaccessible Ceiling--Dense Pack; 4.0103.2 Accessible Attic--Loose Fill Insulation; 4.0103.4 Accessible Attic--Loose Fill Over Existing Insulation; 4.0103.6 Accessible Attic--Dense Pack Insulation; 4/0103.7 Accessible Pitched/Vaulted/Cathedral Ceilings--Loose Fill; 4.0103.8 Loose Fill to Capacity; 4.0103.9-12 Blown Insulation for Flat/Bowed/Vaulted Ceiling; 4.0103.13 Blown Insulation in Roof--Over Construction; 4.0104.1 Knee Wall--Dense Pack; 4.0201 Accessible Walls; 4.0202 Enclosed Walls; 4.03 Floors

Install attic insulation to a cost-effective R-value. Air seal attics before installing attic insulation. Air sealing may require removing existing insulation or debris that obstruct air sealing.

Blown insulation is usually better than batt insulation because blown insulation forms a seamless blanket. Follow manufacturer's instructions for machine settings and coverage charts.

Observe these specifications when blowing attic insulation.

- ✓ Calculate how many bags of insulation are needed to achieve the R-value specified on the work order from the table on the bag's label.
- ✓ Install insulation depth rulers: one for every 300 sq feet.
- ✓ Fill the edges of the attic first, near the eaves or gable end, then fill the center.
- ✓ When filling a tight eave space, push the hose out to the edge of the ceiling. Allow the insulation to fill and pack against the chute or baffle.
- ✓ Install insulation to a consistent depth.
- ✓ Post an insulation certificate at the attic entrance.

Blown-in attic insulation: Blown insulation is more continuous than batts and produces better coverage. Insulation should be blown at a high density to minimize settling and air convection.

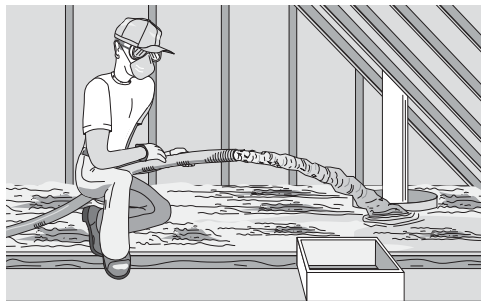

4.2.4 Closed-Cavity Attic Floors

SWS Detail: 4.0103 Attic Floor--Unconditioned Attic; 4.0103.6 Accessible Attic--Dense Pack Insulation

The ceiling joists in the attic are often covered by a wood floor for storage. You may have to remove some floor boards or drill the floor sheathing to install dense pack insulation.



Finished attic floor: Find the large air leaks underneath the flooring and seal them before insulating the space between the joists.

- ✓ Check for live knob-and-tube wiring in the cavity.
- ✓ Check for open electrical junctions.
- ✓ Protect recessed light fixtures and other heat-producing devices in the floor cavity.
- ✓ Thoroughly seal the floor cavity's air leaks before blowing insulation.
- ✓ Dense pack insulation between the ceiling joists.
- ✓ Post an insulation certificate at the attic entrance.

4.2.5 Insulating Closed Roof Cavities

SWS Detail: 4.0101 Exterior Roof Insulation; 4.0101,1 Roof Deck Insulation; 4.0102 Interior Roof Insulation; 4.0188 Unique Installations

Many existing homes have cathedral ceilings or flat roofs that are partially filled with fibrous insulation. The insulation job may include repair of the roof deck and installation of foam insulation over the roof deck. The IRC building code requires one of these two approaches to insulate a roof cavity.

1. Verify or provide a ventilated space of at least one inch between the roof insulation and the roof sheathing by providing soffit and ridge ventilation.
2. If no roof ventilation, then install foam roof insulation in addition to filling the cavity with insulation.

Ventilated Closed Roof Cavities

To prepare for roof-cavity insulation without existing baffles and with a ventilated space above the insulation use this procedure.

- ✓ Remove either the roofing and sheathing or the interior ceiling to gain full access to the cavity.
- ✓ Remove recessed light fixtures and replace them with surface mounted light fixtures. Patch and seal the openings.
- ✓ Install fiberglass or foam insulation to meet the IECC regional minimum roof-assembly R-value requirements.
- ✓ Install openings into the ventilation channel above the insulation totaling $1/300$ of the roof area. If the ceiling has a Class I or II vapor retarder, the requirement is reduced to $1/300$ of the roof area.
- ✓ In cold climates install a Class I or II vapor retarder on the

- ✓ Repair roof leaks or install a new roof. Replace moisture-damaged sheathing as part of the roof replacement.
- ✓ Install an air-barrier ceiling (drywall) if the existing ceiling isn't an adequate air barrier.
- ✓ Seal air leaks to ensure a continuous pressure boundary.

Unventilated Closed Roof Cavities: Decisions

Many homes have cathedral ceilings, vaulted ceilings, or flat roofs that are partially or completely filled with insulation and would require major building surgery to install code compliant roof ventilation or rooftop foam board during retrofit cavity insulation.

Insulators have dense-packed many cathedral roof cavities with fiberglass insulation without ventilation or foam rooftop insulation.

This method is not code compliant. It usually requires special approval by the building department.

Important Note: Dense-packing roof cavities with fiberglass insulation and without ventilation is controversial. The colder the climate, the higher the risk of problems, such as ice damming. Consult a knowledgeable local engineer before deciding to dense-pack a roof cavity with fiberglass. Don't dense-pack roof cavities with cellulose because of its moisture absorption and its susceptibility to moisture damage.

4.2.6 Exterior Rooftop Foam Insulation

SWS Detail: 4.0101 Exterior Roof Insulation; 4.0102 Interior Roof Insulation

Only install rooftop foam insulation over dense-packed roof cavities. A ventilation space between existing insulation and the new rooftop insulation reduces the roof assembly's R-value.

- ✓ Use high density foam board: 2 pcf for polystyrene or 3 pcf for polyisocyanurate if the roof is flat or low sloping.
- ✓ Flash all external penetrations according to the roofing manufacturer's specifications.
- ✓ Use a cool roofing material such as white rubber or white metal to limit the foam's temperature during intense summer sun and to minimize cooling costs.
- ✓ Contact a design professional to ensure the roof will drain properly
- ✓ Install Certificate of Insulation in attic.

4.2.7 Installing Fiberglass Batts in Attics

SWS Detail: 4.0103.1 Accessible Attic--Batt Insulation; 4.0103.3 Accessible Attic--Batt Insulation over Existing

Follow these specifications when installing fiberglass batts in an attic.

- ✓ When layering batts, install new layers at right angles to underlying layers if the top of the existing batts are level with or above the ceiling joist or truss bottom chord.
- ✓ Install unfaced fiberglass insulation whenever possible.
- ✓ If you must install faced batts, install them with the facing toward the heated space. Never install faced insulation over existing insulation.
- ✓ Cut batts carefully to ensure a tight fit against the ceiling joists and other framing.

4.2.8 Roof Deck Underside /Cathedralized Attics

SWS Detail; 4.01 Attics

A cathedralized attic has insulation attached to the bottom of the roof deck and is also called a hot roof. Choose to insulate the bottom of the roof deck instead of insulating the ceiling when the building owner wants to use the attic or to enclose an attic air handler and leaky ducts within the home's thermal boundary.

Important: Insulating the underside of the roof deck presents a risk of moisture problems in the structural sheathing from roof leaks or condensation. To avoid moisture condensation within the insulation or within the structural sheathing during cold weather, install air-impermeable insulation such as closed-cell SPF or install a perfect air barrier and a vapor retarder to the rafters beneath the insulation. (If the job requires a permit, see the IRC for guidance on its recommendations on rooftop insulation, required to prevent condensation and increase the assembly's thermal resistance.)

Provide the client an insulation certificate in the attic.

Spray Foam Roof-Deck Insulation

SWS Detail: 4.0102.1 SPF Roof Insulation--Unvented Roof Deck; 4.0102.2 SPF Roof Insulation--Vented Roof Deck

Use these procedures for spraying high-density, closed-cell foam on the underside of the roof deck.

- ✓ Remove any vapor retarder in the ceiling insulation at the floor of the attic.
- ✓ Create an airtight insulation dam at the eaves to form an air barrier at the roof-wall junction and to prevent spray foam from escaping into the soffit.

- ✓ Spray the foam to cover the entire surface of the cavity.
- ✓ Comply with fire safety provisions of the IRC.

Use **only** high-density closed-cell spray foam for application to the bottom of a roof deck.



Unventilated attic: The unventilated attic or cathedralized attic is a last resort when an air handler and leaky ducts are in the attic.

Fiberglass Roof-Deck Insulation

This application is not code compliant unless there is continuous ventilation between the soffit and ridge vent.

1. Install the rafter's depth of fiberglass batts and then a material or combination of materials that constitutes an air barrier, vapor retarder, and Class I fire barrier.
2. Blow dense-packed fiberglass insulation between the roof deck using a rigid sheeting or flexible insulation restraint.

4.2.9 Vaulted Attics

SWS Detail: 4.0103.7 Accessible Pitched/Vaulted/Cathedral Ceilings

A vaulted attic is framed with a special truss that creates a sloping roof and a sloping ceiling. Access to the cavity varies from difficult to impossible.

Install insulation from either the top of the roof deck or through the ceiling. Insulation installed at the ceiling must have stability to prevent gravity from pulling it downhill .

Consider the following options to insulating uninsulated or partially insulated vaulted attics.

1. Insulate the ceiling with fiberglass batts. Install the batts parallel to the framing if the top of existing insulation is below the framing. Install the batts perpendicular to the framing if the top of the existing insulation is above the framing.
2. Preserve openings into the ventilation space above the insulation.
3. Provide client with an insulation certificate in the attic.

4.2.10 Finished Knee-Wall Attics

SWS Detail: 4.0104 Attic Knee Walls

The finished attics of story-and-a-half or Cape-Cod homes require special care when installing insulation. They often include separate sections that require different air sealing and insulation methods. Air seal before insulating. If necessary, remove the planking and insulation from the side-attic floor to expose the air leaks.

Use these specifications when insulating finished attics.

- Seal air leaks between conditioned and non-conditioned spaces.
- Inspect the structure to confirm that it has the strength to support the weight of the insulation.
- Insulate access hatches to the approximate R-value of the assembly through which it is located.
- Post an insulation certificate at the attic entrance.

Attic floor and knee wall:
Establish an air barrier at the attic floor and knee wall if you insulate these assemblies.

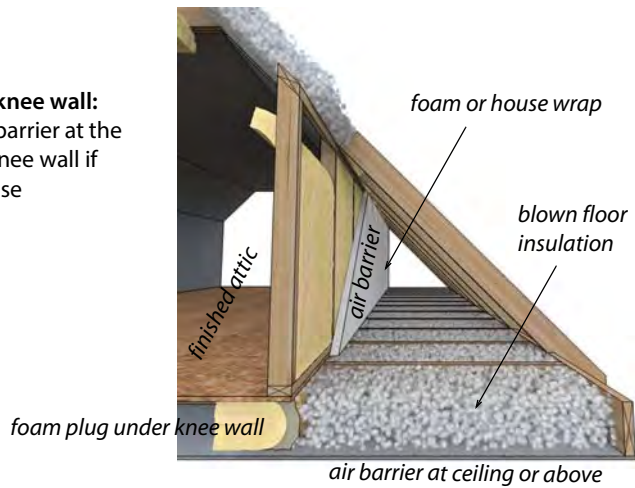

Attic Floor

There are a number of options for insulating the attic floor of a finished attic with knee walls. By attic floor, we mean the ceiling of the living space.

- Install blown fibrous insulation over the ceiling.
- Install blown fibrous insulation over existing insulation.
- Install fiberglass batts over the ceiling.
- Install fiberglass batts over the existing insulation.

Exterior Walls of Finished Attic

Insulate these walls as with closed cavities or as with open cavities.

Collar-Beam Attic

Insulate this type of half-story attic with blown insulation.

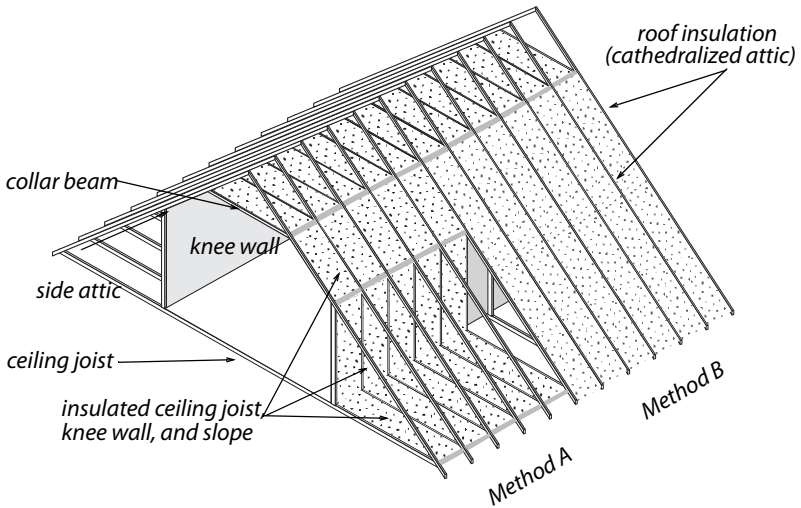

Finished attic: This illustration depicts two approaches to insulating a finished attic. A) insulate the knee wall and side attic floor, or B) insulate the roof deck.

Sloped Roof

Insulate sloped roof with dense packed insulation. Install plugs of fiberglass batt or other vapor permeable material at the ends to contain the blown insulation while allowing vapor diffusion.

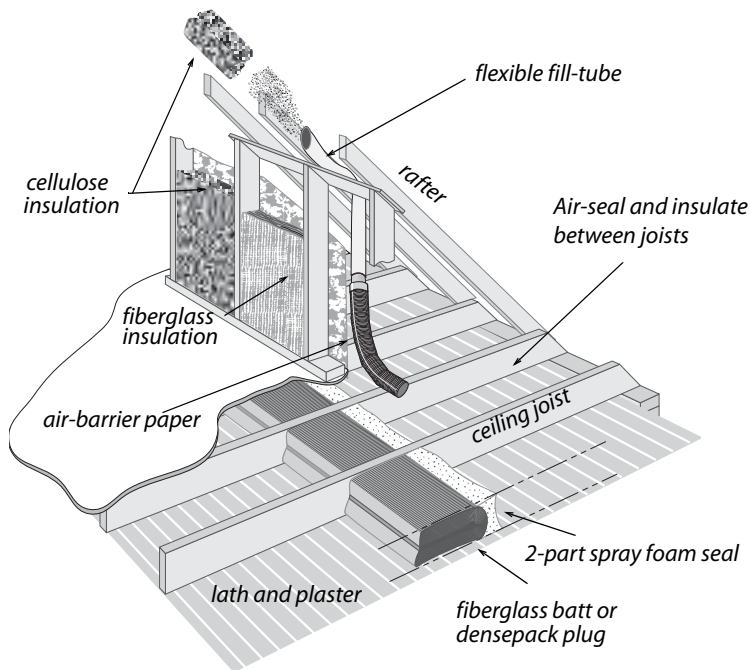

Finished attic best practices: Air sealing and insulation combine to dramatically reduce heat transmission and air leakage in homes with finished attics.

4.2.11 Knee-Wall Insulation

SWS Details: 4.0104 Attic Knee Walls

Insulate knee walls using any of these methods.

- Install unfaced fiberglass batts and cover the insulation with an air barrier on the attic side. Prefer R-13 or R-15, 3.5-inch fiberglass batts.
- Install the air barrier reinforce it with mechanical fasteners that penetrate the substrate 1". Then blow dense-packed fibrous insulation into the cavity through the air barrier and patch hole with tape. (Cellulose: 3.5 pcf; fiberglass 2.2 pcf)

- Spray the cavities with open-cell or closed-cell polyurethane foam after gaining access to the cavities and removing surface dirt to ensure good adhesion. Refer to ESR for thermal and ignition barrier guidance.
- For knee walls without framing, mechanically fasten rigid insulation to the wall's surface and seal the seams.
- Post a certificate of insulation at the attic entrance.

Preparation for Knee-Wall Insulation

Make repairs and seal air leaks before installing the knee-wall insulation.

- ✓ Seal all large air leaks with rigid materials.
- ✓ Seal all joints, penetrations, and other potential air leaks with caulk or foam.
- ✓ Before installing caulk or spray foam insulation, clean dust and materials that might interfere with the adhesion.

Air Sealing and Insulating under the Knee Wall

To seal and insulate under the knee wall, create an airtight and structurally strong seal in the joist spaces under the knee wall. Consider these options.

- Install sealed wood blocking between the floor joists covered with spray foam.
- Insert foam board blocking and foam their perimeters with one-part or two-part foam.
- Insert a fiberglass batt into the cavity and foam its face with an inch of two-part closed-cell spray foam.

4.2.12 Access Doors in Vertical Walls

SWS Detail: 4.1006.2 Access Doors and Hatches

For kneewall access doors, observe the following.

- ✓ Insulate knee-wall access hatches and collar-beam access hatch to the approximate R-value of the assembly through which it is located.
- ✓ Weatherstrip the hatch and install a latch or other method to hold the access door closed against the weatherstrip.

Insulated access door in knee wall: Achieve an R-value as close to the wall as practical. Weatherstrip the door and install some type of latch.

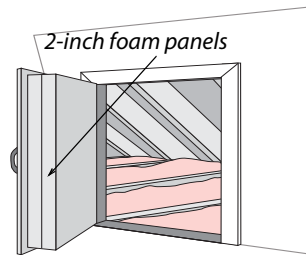

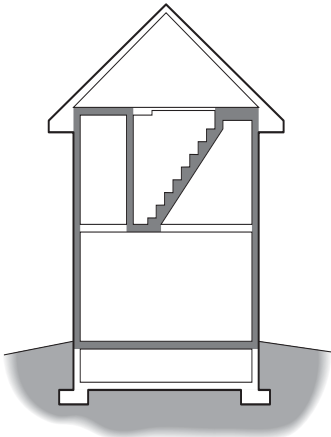

Insulating and sealing attic stair walls, doors, and stairs: Insulating and air sealing these is one way of establishing the thermal boundary.

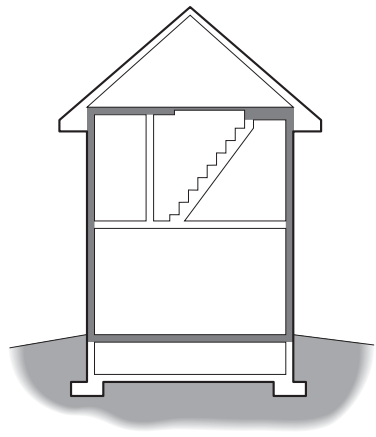

Insulating and weatherstripping the attic hatch: Air sealing around the hatch and insulating the hatch is an alternative method.

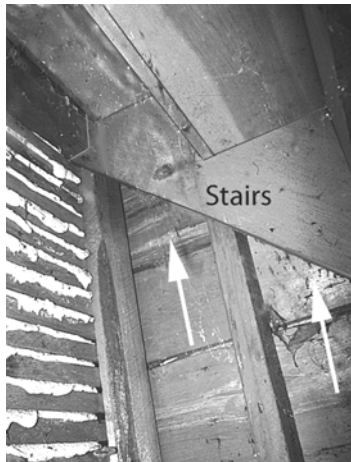

4.2.13 Walk-Up Stairways and Doors

Think carefully about how to install continuous insulation and air barrier around or over the top of an attic stairway. If you enter the attic by a stairwell and standard vertical door, use these instructions.

- ✓ Blow dense-pack fibrous insulation into walls of the stairwell.
- ✓ Install a threshold or door sweep, and weatherstrip the door.
- ✓ Insulate or replace the door with an insulated door if cost effective.
- ✓ Blow dense-packed insulation into the sloping cavity beneath the stair treads and risers.

You can also establish the thermal boundary at the ceiling level, but this requires a horizontal hatch at the top of the stairs.

When planning to insulate stairwells, investigate barriers such as fire blocking that might prevent insulation from filling cavi-ties you want to fill. Also consider what passageways may lead to areas you don't want to fill such as closets.

4.2.14 Insulating & Sealing Pull-Down Attic Stairways

Pull down attic stairways are sometimes installed above the access hatch. Build a weight supporting foam insulated box over the top. Install weatherstripping around the insulated box.

Educate the client on the purpose and operation of stair-and-hatchway cover and educate them to replace it when they access the attic.

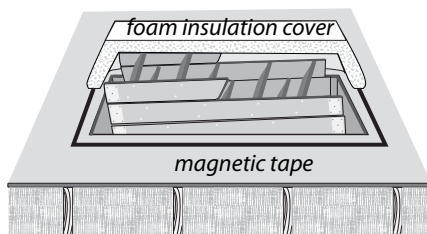

Manufactured pull-down-stair covers: Manufacturers provide insulated stair covers for use with walkable attic floors or with dams to be surrounded by fibrous insulation.

4.2.15 Parapet Walls

Parapet walls are a continuation of exterior walls that rise above the roof. Parapet walls are often an air-leakage and thermal bridging problem because the insulation and air barrier are not continuous.

Inspect the parapet area from both indoors and outdoors and decide how to connect the wall insulation and air barrier with the roof insulation and air barrier. Consider these two alternatives.

1. Install an air barrier and dense-pack the wall cavity of the parapet.
2. Spray foam the parapet to connect the insulation and air barrier of the exterior wall with attic or roof insulation and air barrier.

4.2.16 Skylights

Skylights are places where the insulation and air barrier may not be continuous. Install insulation and air seals as necessary,

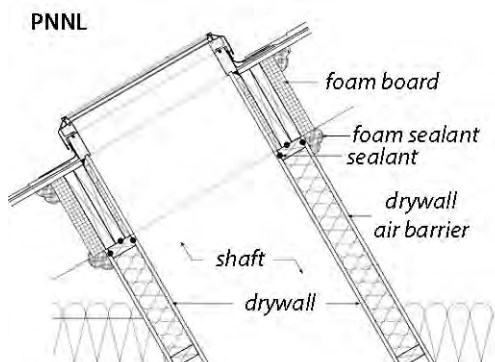

Insulated and air sealed skylight: The skylight shaft must be insulated and air sealed from the ceiling to the roof.

4.2.17 Whole-House Fans

SWS Detail: 3.0103.3 Whole House Fan

Refer to the SWS for detailed guidance.

Whole-house fans can leak a lot of air if they lack an airtight seasonal cover. Whole-house fans can also create significant thermal bridging if they aren't dammed and insulated thoroughly around their perimeter.



Whole house fans: The whole-house fan has a dam to allow the sides of its opening to be thoroughly insulated.

CHAPTER 5: WALLS

This chapter discusses air sealing and insulation for walls in existing buildings. Inspect all walls for air infiltration and presence of insulation.

5.1 AIR SEALING WALLS

SWS Detail: General Pressure Boundary

Air leakage in walls can be determined with use of infrared camera, blower door, and pressure diagnostics.

5.1.1 Multifamily Firewalls

Firewalls are structural walls between buildings or dwelling units that prevent the spread of fire from one unit to another. Air-sealing between building materials on the two sides of the fire wall and the fire wall itself is an important safety and energy-conservation task.

- ✓ When air-sealing, preserve existing fire ratings of materials and assemblies along with existing-material compatibility and comparable durability.
- ✓ Verify that non-monolithic fire walls, such as balloon-framed walls, are airtight assemblies both to air flowing horizontally and vertically. Improve airtightness as necessary through air sealing and dense-packing with fibrous insulation.
- ✓ Seal air channels, created by furring strips or wall framing, against a monolithic firewall. At a minimum seal the top and bottom of each channel, and/or densepack the channels with fibrous insulation.
- ✓ Seal gaps and cracks with air-sealing materials and backing materials that are compatible with and similar to existing materials with fire-containment functionality.

5.1.2 Built-In Cabinets/Shelves

Built-in cabinets and shelves can present challenges when air sealing and insulating. When possible, establish the thermal and pressure boundary behind the cabinet.

Built-ins and other connected air leaks: Built-in cabinets, a chimney chase, and recessed lights create a major air leakage problem in this living room.



5.1.3 Wall Framing Around Fireplaces and Chimneys

Leaks around fireplace chimneys are often severe air leaks. Use this procedure to seal air leaks through the chimney chase.

Refer to IHCDA State Plan and WPN 17-7 for addressing fireplaces and chimneys



Chimney chase: Chimney chases can be multistory air-leak conduits if they're not sealed at floors and ceilings.

When located on the second floor, cap the top of the entire wall cavity in the attic with rigid board, caulked and mechanically fastened.

Pocket doors connected to the exterior walls present difficult air sealing and insulating challenges. You may need to address these framing situations from the exterior in order to install a durable and efficient repair that provides a good air seal and allows you to install insulation into the exterior wall cavity

5.1.4 Cooling Appliances Installed through Walls or Windows

Room air conditioners, room heat pumps, and evaporative coolers are sometimes installed through walls or in windows. The units installed in windows are often very leaky because of the temporary nature of the air seals.

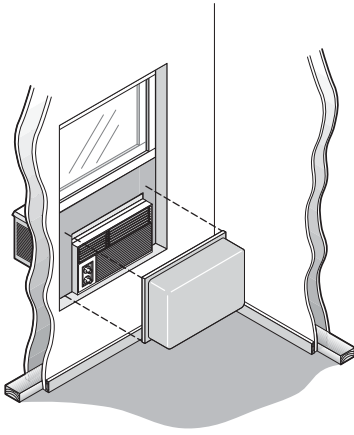

Room-air-conditioner cover: If you can't take the unit out for the winter, cover it with a room-air-conditioner cover.

- Remove window units in the fall and reinstall in the spring.
- If the client doesn't want to remove the unit seasonally, cover the unit with a room air conditioner cover.
- Units installed through walls should have a sheet-metal sleeve that seals well to the surrounding framing and finish. This metal sleeve provides a smooth surface to seal to the room air conditioner or heat pump.
- Seal the unit's perimeter with suitable materials.

5.1.4 Balloon Framed Walls

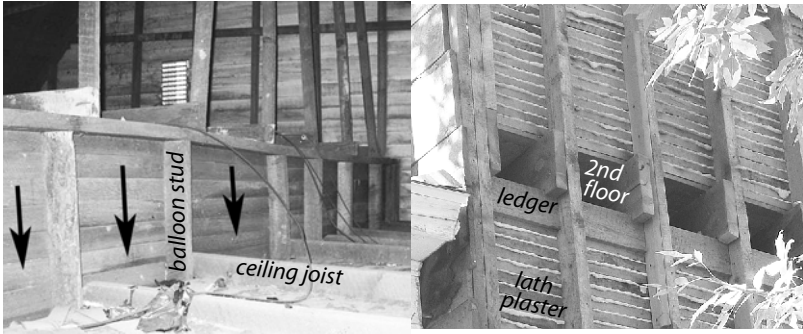

Balloon framed walls: Wall cavities, shown from outdoors at right and from the attic at left, are open to the floor cavity, the attic, and the crawl space.

Balloon framing is common in older homes. Some modern homes have balloon framed gable walls.

Even when balloon framed gable walls are full of insulation, air can convect through the insulation if the top is not air sealed.

- ✓ Dense-pack insulation into the wall cavities.
- ✓ Dense-pack insulation into an air-permeable bag inserted with the fill tube into the second floor band joist.
- ✓ Seal from attic, basement, and/or crawl with an insulation plug covered with a foam sealant or rigid air barrier foamed in place.

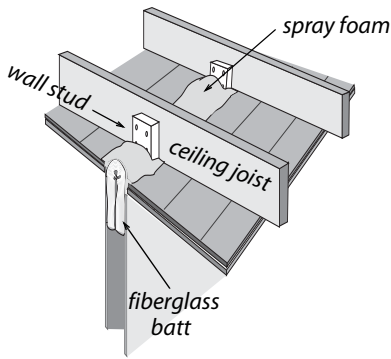

interior wall

Balloon framed interior walls:
Fiberglass insulation covered by a 1-inch layer of two-part foam seals wall cavities.

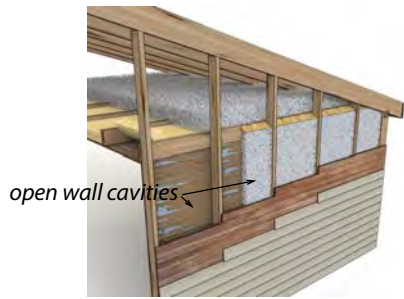

Balloon framed gable: Studs extend above the ceiling allowing convection from the attic.

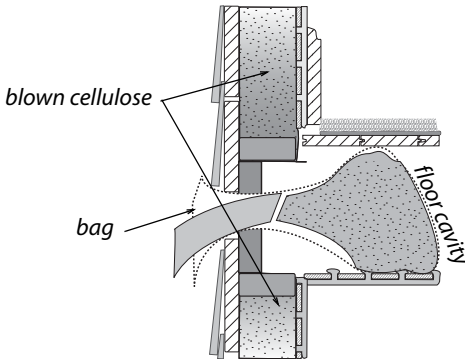

Sealing wall-floor junction:
Blown insulation reduces convection through walls and floors. A bag helps contain and pack the blown insulation that extends into the floor cavity.

5.2 MINOR AIR SEALING

Minor air sealing includes sealing small openings with such materials as caulk or weather stripping.

5.2.1 Window and Door Frames

Sealing from the exterior serves to keep bulk water out and protect the building. If the crack is deeper than $\frac{5}{16}$ -inch, it should be backed with a material such as backer rod and then sealed with caulk. Any existing loose or brittle material should be removed before the crack is caulked.



Silicone bulb weatherstrip: Silicone bulb has its own adhesive or is adhered to surfaces with silicone caulking.

5.2.2 Rim Joist Area

The rim joist area is composed of several joints. They can be sealed from the basement or crawl space with caulk or foam. *See also "Rim-Joist Insulation and Air-Sealing".*

5.2.3 Masonry Surfaces

Masonry surfaces are best sealed with a patching compound, mortar mix, or high quality caulking, such as polyurethane. For cement based patches, buy a mix designed for patching and prime the damaged areas with a concrete adhesive.

5.2.4 Interior Wall Top Plates

The top plates of interior walls are open to the attic. Top plate shrinkage opens up cracks that run the entire length of the interior wall. Move insulation and seal the cracks .

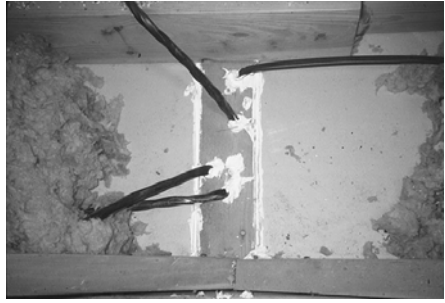
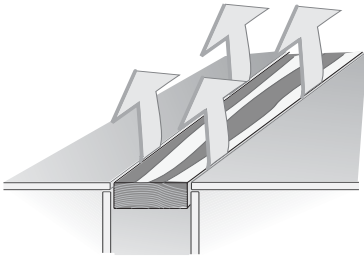

Leaky top plates: The cracks along top plates are from lumber shrinkage. They are small cracks but there are long lengths of them.

5.3 WALL INSULATION

Install wall cavity insulation with a uniform coverage and density. Wall cavities encourage airflow like chimneys. Convection currents or air leakage can significantly reduce wall insulation's thermal performance.

Important: Provide the client with an insulation certificate.

Wall Insulation Types

- Cellulose
- Fiberglass
- Open cell polyurethane foam

Table 5-1: Wall Insulation Density and R-Value per Inch

Insulation Material	Density	R-Value/in.
Fiberglass (virgin fiber)	2.2 pcf	4.3
Cellulose	3.5 pcf	3.2
Open-cell urethane foam	0.5 pcf	3.8
pcf = pounds per cubic foot		

5.3.1 Wall Insulation: Preparation and Follow-up

SWS Detail: 4.02 Walls; 4.0104 Attic Knee Walls

Inspect and repair walls to avoid damaging the walls, blowing insulation into unwanted areas, or causing a dust hazard.

Preparing for Wall Insulation

Before starting to blow insulation into walls, take the following preparatory steps.

- ✓ Calculate number of bags of insulation needed.
- ✓ Inspect walls for evidence of moisture damage. If an inspection of the siding, sheathing, or interior wall finish shows a moisture problem, don't install sidewall insulation until the moisture problem is identified and solved.
- ✓ Inspect interior surfaces of exterior walls to assure that they are strong enough to withstand the force of dense packing. Reinforce interior sheathing as necessary.
- ✓ Inspect for interior openings or cavities through which insulation may escape. Seal these openings.
- ✓ If exterior wall cavities are being used as return or supply ducts, either avoid insulating these cavities or install new ducts.
- ✓ Do not insulate cavities containing knob-and-tube wiring.
- ✓ Interior holes will be coated and patched to match original interior surface characteristics or covered with trim as agreed upon with client.

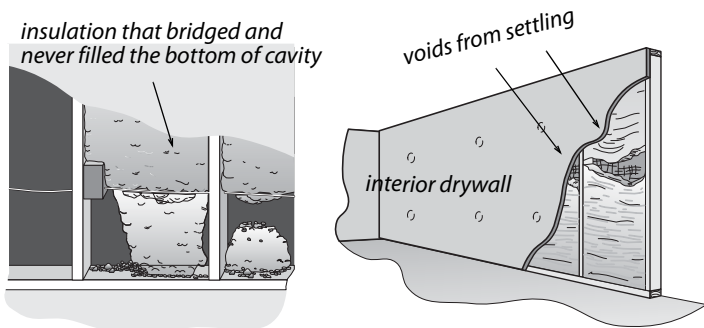

Problems with low density insulation: Blowing insulation through one or two small holes usually creates voids inside the wall cavity. This is because insulation won't reliably blow at an adequate density more than about one foot from the nozzle. Use tube-filling methods when possible, using a 1.5-inch hose inserted through a 2-inch or larger hole.

Wall Insulation Quality Control

Retrofit wall insulation has risk of incomplete application. Consider these quality control options to verify the proper coverage and density of retrofit wall insulation.

- View the wall with an infrared camera.
- Inspect an electrical outlet or access hole for insulation.
- Verify installed weight with calculated weight/bag count.

Drilling Exterior Sheathing: Insulation Retrofit

Avoid drilling through siding. When possible, carefully remove siding and drill through sheathing.

If you can't remove the siding, consider drilling the walls from inside. Obtain the owner's permission before drilling indoors. Practice lead safe work practices.

Consider these possible methods of removing siding.

- Cut through the paint on wood siding joints with a sharp utility knife before carefully prying the siding off.
- Remove asbestos shingles by pulling the nails holding the shingles to the sheathing or cut off the nail heads. Dampen the asbestos tiles to reduce dust. Utilize appropriate PPE.
- Use a zip tool to remove metal or vinyl siding.

- Insulate homes with brick veneer or blind-nailed asbestos siding from the indoors.

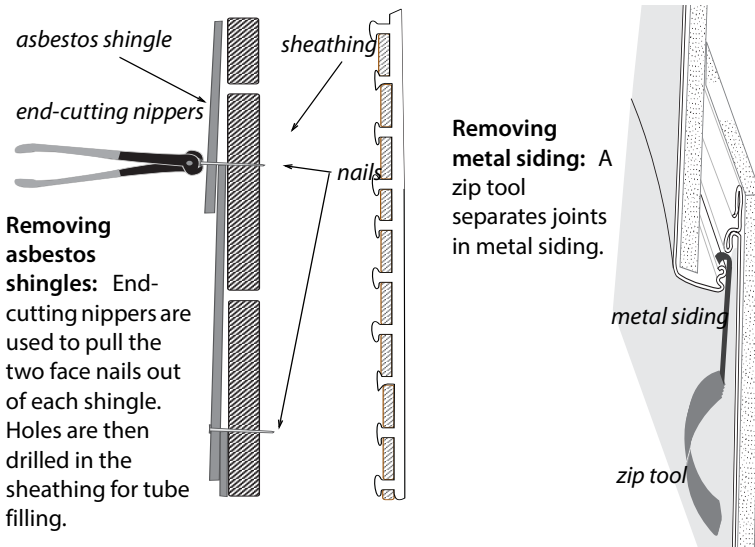

5.3.2 Retrofit Closed-Cavity Wall Insulation

SWS Detail: 4.0202.1 Dense Pack Insulation; 4.0202.5 Blown Fiberglass Through Penetrations; 4.0202.6 SPF Insulation Installation in Closed Cavities

Blow walls with insulation using a fill tube from indoors or outdoors

Blowing Walls with a Fill-Tube

Install dense pack wall insulation using a blower equipped with separate controls for air and material feed. Mark the fill tube in one-foot intervals to help you verify when the tube reaches the top of the wall cavity.

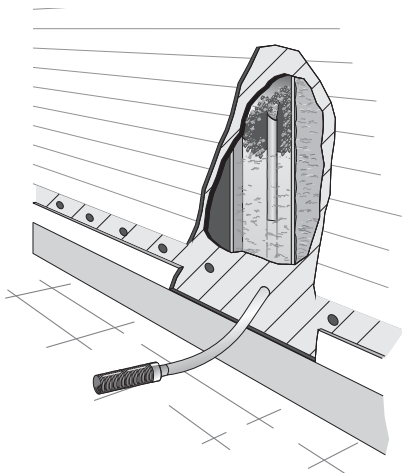

Tube-filling walls: This method can be accomplished from inside or outside the home. It is the preferred wall insulation method because it is a reliable way to achieve a uniform coverage and density.

To prevent settling, cellulose insulation must be blown to at least 3.5 pounds per cubic foot (pcf) density. Fiberglass dense-pack must be 2.2 pcf or to manufacturer's specifications and the fiber-glass material must be designed for dense-pack installation.

Insulate walls using this procedure.

1. Drill 2-to-3-inch diameter holes to access the stud cavity.

2. Probe all wall cavities through holes before you fill them in order to identify fire blocking, diagonal bracing, and other obstacles.
3. Start with several full-height, unobstructed wall cavities so you can measure the insulation density and calibrate the blower. An 8-foot cavity (2-by-4 on 16-inch centers) should consume a minimum of 10 pounds of cellulose or 6 pounds of fiberglass.
4. Insert the hose all the way to the top of the cavity. Start the machine, and back the hose out as the cavity fills.
5. Fill the bottom of the cavity in the same manner.
6. After probing and filling, drill additional holes necessary for complete coverage. For example: above windows, missed areas with fire blocking.
7. Seal and plug the holes, repair the weather resistive barrier, and replace the siding.

Insulating the Wall-Floor Junction of Two-Story Walls

When insulating the perimeter of walls between the first and second floors, blow an insulation plug into the perimeter floor cavities for both thermal resistance and airflow resistance. This method is particularly effective for platform framed walls because the wall insulation is discontinuous at the floor cavity unless you drill and blow through the rim joist there.

This insulation plug prevents the floor cavity from being a thermal bridge and an air-leakage conduit. Using a fill tube, blow the insulation into a air-permeable bag that expands inside the cavity.

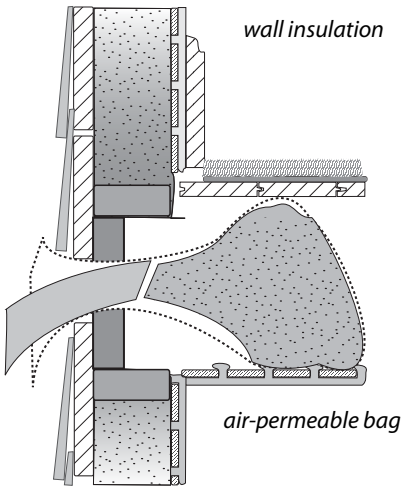

Floor cavities: Floor cavities are difficult to fill in platform-framed homes. Blow a plug of insulation into the floor cavity to insulate this uninsulated area.

5.3.3 Open-Cavity Wall Insulation

SWS Details: 4.0201 Accessible Walls; 4.020201.2 Batt Insulation; 4.0201.1 SPF Insulation; 4.0201.3 Dense Pack Insulation

Fiberglass batts are the most common open-cavity wall insulation. If there are gaps between the cavity and batt at the top and bottom, the R-value can be reduced significantly. The batt should fill the entire cavity without spaces in corners or edges.

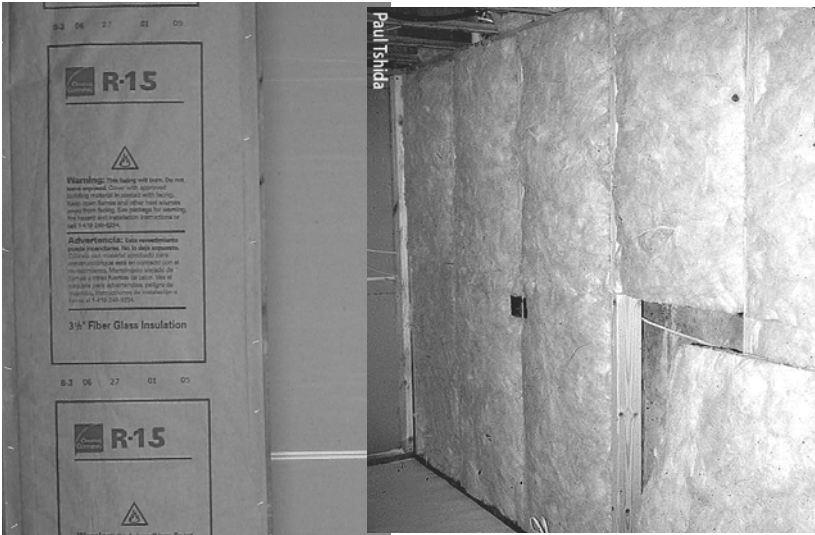

R-15 fiberglass batts: Install R-15 batts in open walls and attach them to the face of the stud as shown on the left. Or install unfaced batts as shown on the right. Either way, cut the batts accurately and install them carefully.

- ✓ Use unfaced friction-fit batt insulation when possible. Fluff the batts during installation to fill the depth of the wall cavity.
- ✓ Choose medium or high density batts: R-13 or R-15 rather than R-11, and R-21 rather than R-19.
- ✓ Seal all significant cracks and gaps in the wall structure before you install the insulation.
- ✓ Insulate behind and around obstacles with scrap pieces of batt before installing batts.
- ✓ Staple faced insulation to outside face of studs on the warm side of the cavity. Do not staple the facing to the side of the studs.

- ✓ Split batt around wiring.
- ✓ Fiberglass insulation exposed to the living space must be covered with minimum half-inch drywall or other material that has an ASTM flame spread rating of 25 or less.
- ✓ Vertically installed, fiberglass batts exposed to unoccupied spaces such as attics must be covered with an air barrier.

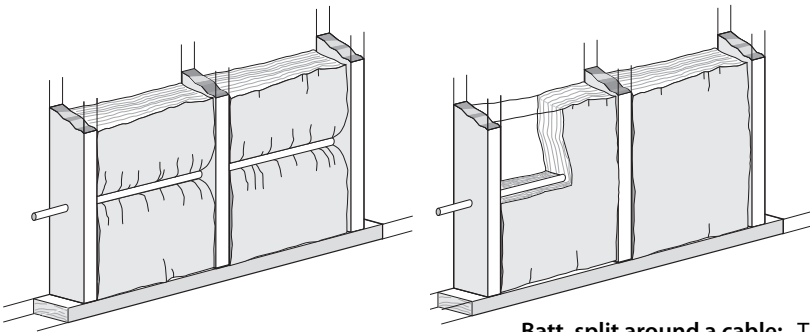

Batt, split around a cable: The batt attains its rated R-value.

Fiberglass batts, compressed by a cable:

This reduces the wall's R-value by creating a void between the insulation and interior wallboard.

Sprayed Open Cavity Wall Insulation

Both fibrous and foam insulation can be sprayed into open wall cavities. Varieties include the following.

- Fiberglass or cellulose mixed with water and glue at a special nozzle sprayed into the open wall cavity with the excess shaved off (fibrous damp-spray insulation).



Spraying open-cell foam: The sprayed open-cell foam is left short of filling the cavity or else shaved off.

- Open-cell or closed-cell polyurethane foam sprayed into an open wall cavity and either held short of filling the whole cavity or with the excess foam shaved off after it cures.

Blowing Open Wall Cavities behind Netting or Fabric

Blowing dry fibrous insulation behind netting or fabric is a common way of insulating open walls before drywall application, especially with cellulose. You must install the insulation to a sufficient density to resist settling.

- ✓ Verify density of at least 3.5 pcf (or per manufacturer's recommendation) for cellulose or 2.2 pcf (or per manufacturer's recommendation) for fiberglass.
- ✓ Select a restrainer netting or fabric that will allow the above densities without bulging excessively.
- ✓ Fasten the netting or fabric with power-driven staples, 1.5 inches apart.
- ✓ Roll bulging insulation with a roller to facilitate drywall installation.

5.3.4 Insulated Wall Sheathing

SWS Detail: 4.0201 Accessible Walls

Insulated wall sheathing covers the wall surface with insulation, reducing thermal bridging through structural framing. Insulated sheathing is an excellent retrofit, when you replace the siding and windows.

Insulating wall sheathing is usually foam board, such as polystyrene or polyisocyanurate. Always fill the wall cavity with insulation before installing insulated sheathing.

Fastening Insulating Sheathing

Fastening the insulating sheathing requires one of the following to secure the insulation to the wood sheathing or masonry under it.

- A batten board
- An embedded strip
- A broad staple
- A long screw with a large washer
- A special adhesive (masonry)

Use appropriate fasteners for wood or masonry materials. Wood battens or embedded strips allow attachment of a variety of siding materials. The embedded strips work best with steel, aluminum, or vinyl siding.



Foam sheathing with battens: One-by-four battens are applied to 4 inches of foam board on the exterior to provide a fastening strip for siding and trim.

Foam with embedded strips: Strips of plywood or OSB are spaced on 16 or 24 inch centers at the factory. Wide corner pieces can be added on the job with foam cutting and grooving tools.



5.3.5 Insulating Unreinforced Brick Walls

SWS Detail: 4.0201 Accessible Walls; 4.0202 Enclosed Walls

Unreinforced means that the builders used no steel or other metal reinforcement. Consult a structural engineer prior to making any modifications to an unreinforced brick structure.

CHAPTER 6: FLOORS AND FOUNDATIONS

The importance of defining the thermal boundary at the building's lower reaches depends on how much of the building's heat loss is moving through the foundation or floor. The building's thermal boundary may not be obvious because of the lack of insulation at both the floor and the foundation. The energy auditor must choose where to insulate and air seal if these ECMs are cost-effective.

6.1 THERMAL-BOUNDARY DECISIONS: FLOOR OR FOUNDATION

SWS Detail: 3.1401.1 3.0104 Foundation Spaces; 4.0301 Accessible Floors; 4.0302 Exposed Floors; 4.04 Conditioned Subspaces

The results of pressure diagnostics can help in determining the pressure boundary location.

Moisture problems, the location of heating and cooling equipment, and the necessity of crawlspace venting are considerations.

House-to-crawl-space pressure:

Many homes with crawl spaces have an ambiguous thermal boundary at the foundation. Is the air barrier at the floor or foundation wall? Answer: in this case, each forms an equal part of the home's air barrier.

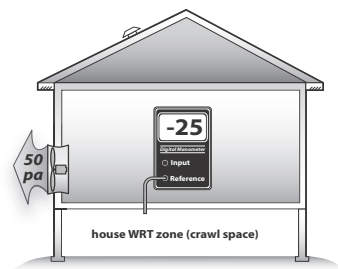

The tables presented next summarize the decision factors for choosing between the floor and the foundation wall as the air

barrier.

When a home has a basement and crawlspace connected, both of the tables below are relevant to the decision-making process. Most often, basements are intended to be isolated from adjoining crawlspaces.

Table 6-1: Crawl Space: Where Is the Thermal boundary?

Factors favoring foundation wall	Factors favoring floor
Ground moisture barrier and good perimeter drainage present or planned. Dry	Wet crawlspace with ground moisture barrier installed during weatherization
Foundation walls test tighter than floor	Floor air-sealing and insulation are reasonable options, considering access and obstacles
Vents can be closed off	Floor tests tighter than foundation walls
Furnace, ducts, and water pipes located in crawl space	No furnace or ducts present
Concrete or concrete block walls are easily insulated	Building code or code official forbid closing vents
Floor air sealing and insulation would be more difficult than sealing and insulating the foundation	Rubble or brick masonry foundation wall
Foundation wall is insulated	Floor is already insulated

Table 6-2: Unoccupied Basement: Where Is the Thermal Boundary?

Favors foundation wall	Favors floor
Ground drainage and no existing moisture problems	Damp basement with no solution during weatherization
Interior stairway between house and basement	Floor air-sealing and insulation is a reasonable option, considering access and obstacles
Ducts and furnace in basement	No furnace or ducts present
Foundation walls test tighter than the floor	Floor tests tighter than foundation walls
Basement may be occupied some day	Exterior entrance and stairway only
Laundry in basement	Rubble masonry foundation walls
Floor air-sealing and insulation would be very difficult	Dirt floor or deteriorating concrete floor
Concrete floor	Cracked foundation walls

6.2 AIR SEALING FOUNDATIONS AND FLOORS

The floor and foundation are complex structures that can be difficult to air seal.

6.2.1 Garages Underneath Living Areas/Tuck Under Garage

SWS Detail: 3.0105.1 Isolating garage from living space. Also, must comply with ASHRAE 62.2

Whenever a garage is in a subspace below living areas, the effectiveness of air sealing is essential for three objectives.

1. Block air pollutants,

2. Create a fire barrier,
3. Save energy by separating the unconditioned garage from the building's conditioned zones.

Air sealing a garage from living space is important for health and safety as well as important for energy saving.

Refer to the *ASHRAE Standard and the SWS 3.0105.1 Isolating garages from living spaces*

6.2.2 Plumbing Penetrations

SWS Detail: 3.01 General Pressure Boundary; 3.0104 Foundation spaces

Seal gaps with expanding foam or caulk. If the gap is too large, fill it with fiberglass insulation and spray foam over the top to seal the surface of the plug.

- ✓ Fit large openings with a rigid patch bedded in a sealant like latex caulk or foam tape, which isn't an adhesive.
- ✓ Screw the patch in place so that a plumber can remove the screws if necessary for access.
- ✓ Seal holes and gaps around pipes with expanding foam or caulk.
- ✓ Seal penetrations in the foundation wall with hydraulic cement.



Sealing large plumbing penetrations: Bed drywall or wood sheathing in sealant and fasten with nails or screws. Fill gaps around the penetrations with one-part foam to complete this airtight seal.

6.2.3 Stairways to Unconditioned Areas

SWS Detail: 3.01 General Pressure Boundary; 4.01 Attics

A variety of stairways and hatchways provide access from the building to an unconditioned basement.

The following components of these stairways may need air sealing and insulation depending on whether they are at the thermal boundary.

- The risers and treads of the stairways
- The surrounding triangular walls
- Vertical or horizontal doors or hatches
- The framing and sheeting surrounding the doors or hatches
- Sloping ceilings above the stairways

Consider the following air-sealing measures.

- ✓ Study the geometry of the stairway and decide where to establish the air barrier and install the insulation.
- ✓ Weatherstrip around doors and hatches if the door or hatch is at the thermal boundary.
- ✓ Seal the walls, stair-stringer space, and ceiling if they are at the thermal boundary.
- ✓ Seal gaps around door frame or hatch frame perimeters with one-part foam, two-part foam, or caulking.
- ✓ Insulate or install an insulated door if it is part of the thermal boundary.

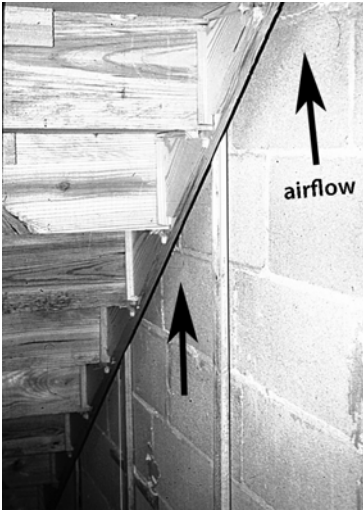

Unfinished stairways: Unfinished spaces underneath stairs create major air leakage pathways between floors and between the attic and crawl space or basement.

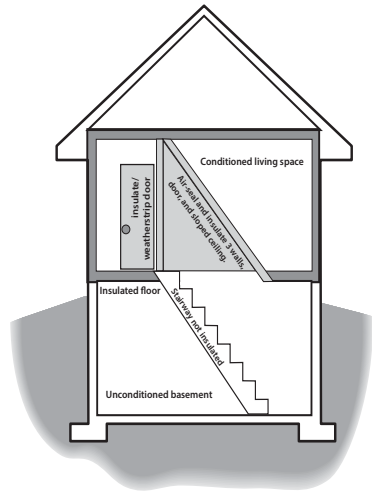

Stairways at the thermal boundary: The stairway may be within the thermal boundary or outside it. Only walls, ceilings, doors, and hatches at the thermal boundary require thorough air sealing. The door as shown is open.



Stairway wall within the thermal boundary: Double wall forming the stairwell connects an unfinished area under the basement stairs with the living spaces, attic, and the space behind the finished basement walls.

6.2.4 Incomplete Finished Basements

Discontinuous wall segments can allow heated basement air to circumvent the finished and insulated wall, carrying heat with it. Complete the finished walls or at least install air barriers between finished living area and unconditioned area between the insulated wall and the foundation wall. Here are two suggestions.

- ✓ Bridge the gap with wood sheeting, bedded in sealant, and caulk the crack around four sides of this long narrow patch.
- ✓ Stuff the gap with pieces of fiberglass batt and spray two-part foam over the gap, at least an inch thick.

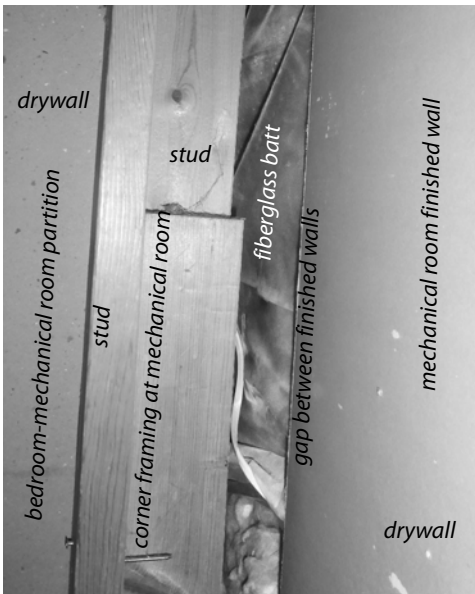

Large air leak in finished basement walls: Two finished basement walls meet inside a mechanical room and form a 2-inch gap from floor to ceiling connecting the finished basement with the space behind its finished walls.

6.2.5 Cantilevered Floors

SWS Detail: 4.0301 Accessible Floors; 4.0302 Exposed Floors; 4.0301.6 Cantilever Floor Joisted Cavities Ball Insulation; 4.0301.5 SPF in Open Joisted Cavities

Floors that hang over their lower story are called cantilevered floors. The underside of the overhanging floor can leak considerably. Many balconies and bay windows have cantilevered floors that leak air into a building's floor cavity.

Cantilevered floors under construction: Cantilevered floors allow air leakage into floor cavities because of the lack of sealant and dense-packed insulation.

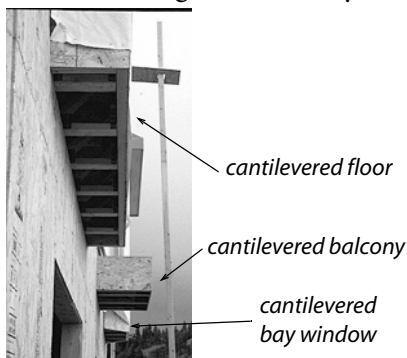

- ✓ Remove a piece of soffit under the overhanging floor to determine the condition of insulation and air barrier.
- ✓ Fill the overhanging floor with fiberglass batts or blown fibrous insulation.
- ✓ Bed the sheeting underneath the overhanging floor in sealant where possible. Caulk joints and seams where the sheeting isn't bedded in sealant.
- ✓ Seal any ducts you find in the cantilevered floor sections.
- ✓ Reinstall soffit under the air barrier.

6.3 PREPARING FOR FOUNDATION OR FLOOR INSULATION

SWS Detail: 2.02 Moisture; 3.01 General Pressure Boundary; 3.0104 Foundation Spaces

Floor and foundation insulation can exacerbate existing moisture problems. Installers should take steps to prevent moisture problems from ground moisture before installing insulation.

6.3.1 Rim-Joist Insulation and Airsealing

SWS Detail: 3.01 General Pressure Boundary: 4.0201 Accessible Walls; 4.03 Floors; 4.0301 Accessible Floors; 4.0302 Exposed Floors; 4.0388 Unique Installations; 4.0401 Rim/Band Joist

The rim joist spaces at the perimeter of the floor are a weak point in the air barrier and insulation. Insulating and air sealing the rim joist and box joist are appropriate either as individual procedures or as part of floor or foundation insulation.

Air seal stud cavities in balloon-framed homes as a part of insulating the rim joist. Air seal other penetrations through the rim before insulating. Two-part spray foam is the most versatile air sealing and insulation system for the rim joist because spray foam air seals and insulates in one step.

Polystyrene or polyurethane rigid board insulation are also good for insulating and air sealing the rim joist area. When the rim joist runs parallel to the foundation wall, the cavity may be air sealed and insulated with methods similar to those as shown here.

If you leave the spray foam exposed, it should have a flame spread of 25 or less and be no more than 3.25 inches thick

according to the IRC. In habitable spaces, cover all foam with a thermal barrier such as drywall or use an insulation product that doesn't require a thermal barrier like mineral wool boards and foil-faced PIC. The installer must verify material fire safety requirements prior to installing PIC without a thermal barrier.

See SWS 4.0401.3f.

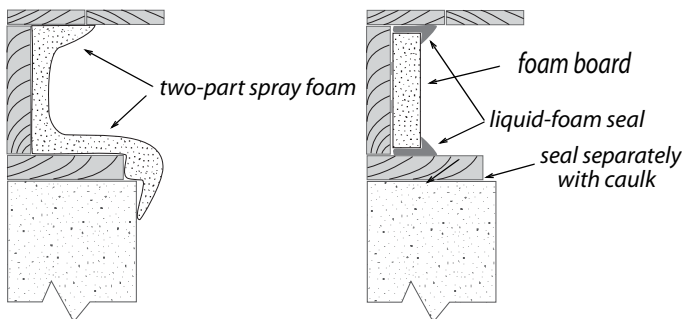

Foam-insulated rim joists: Installing foam insulation is the best way to insulate and air seal the rim joist.

Foam-insulated rim joists: Here 4 inches of EPS foam is sealed around its perimeter with one-part foam.



Vinyl backed fiberglass may be used to insulate between rim joists if it is installed tight to the wood and sealed at all edges. If you use foam to insulate between the rim joists, use liquid foam sealant to seal around the edges of the rigid foam.

If wood moisture content is greater than 20% or there are other indicators of moisture issues, the moisture issues shall be remedied and the wood dried out prior to insulating or air sealing rim joists and sill plate.

6.3.2 Installing Floor Insulation

SWS Details: 4.03 Floors: 4.0301 Accessible Floors; 4.0302 Exposed Floors; 4.0388 Unique Installations; 4.04 Conditioned Subspaces; 2.0202 Ground Vapor Retarders

Before installing floor insulation, make the following preparations.

- ✓ Seal air leaks in the floor from the living space or the crawl space or basement.
- ✓ Seal and insulate ducts remaining in the crawl space or unconditioned basement.
- ✓ Identify electrical junction boxes, plumbing valves and drains before insulating and provide access to them.
- ✓ Insulate water lines in cold climates if they protrude below the insulation.

Blowing Floor Insulation

The best way to insulate a floor cavity is to completely fill each joist cavity with fiberglass insulation. Blowing fiberglass insulation is the easiest way to achieve complete coverage because the blown fiberglass is able to surround obstructions and penetrations better than fiberglass batts. Avoid blown cellulose because of its weight, moisture absorption, and tendency to settle.

- ✓ Cover the entire under floor surface with a vapor permeable supporting material.

- ✓ Use wood strips to support the flexible or semi-flexible support material.

Blown floor insulation: This method works particularly well with floor trusses.

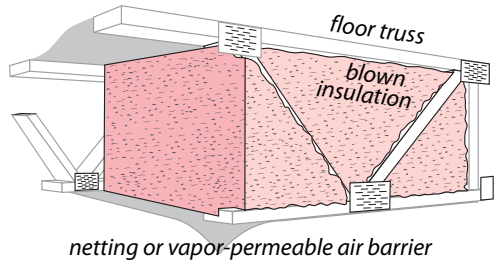

- ✓ Install rock wool or fiberglass blowing wool through V-shaped holes in the air barrier.
- ✓ Seal all penetrations in the air barrier with a tape, approved for sealing seams in the air-barrier material.

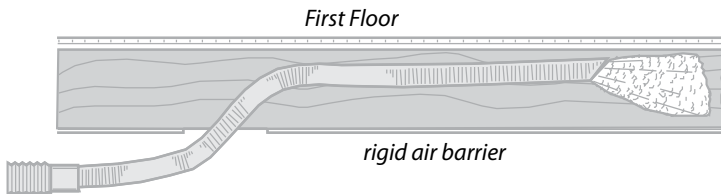

Blowing floor cavity: Uninsulated floor cavities can be blown with fiberglass or rock wool insulation, using a fill tube.

6.3.3 Installing Fiberglass Batt Floor Insulation

SWS Detail: 4.0301 Accessible Floors: 4.0301.1 Batt Insulation in Joisted Cavities; 4.0301.7 Non-Joisted Floors-batt insulation; 4.0302.1 Batt Insulation with Rigid Barrier; 4.0302.6 Non-Joisted Floors-batt insulation 4.0401.2 Batt Insulation

Observe these material and preparation specifications for insulating under floors.

- ✓ Choose unfaced or encapsulated batts for insulating floors.
- ✓ Seal air leaks through the floor before insulating the floor.
- ✓ Installed floor insulation R-value must be cost effective.
- ✓ Batt s must be neatly installed, fitting tightly together at joints and fitted closely around obstructions.
- ✓ Secure batts in full contact with the pressure boundary using physical fasteners that do not compress the insulation and have a minimum service life of 20 years and be installed per manufacturers specifications.
- ✓ Crawl-space access doors, adjacent to a conditioned space, must be effectively weatherstipped and insulated.

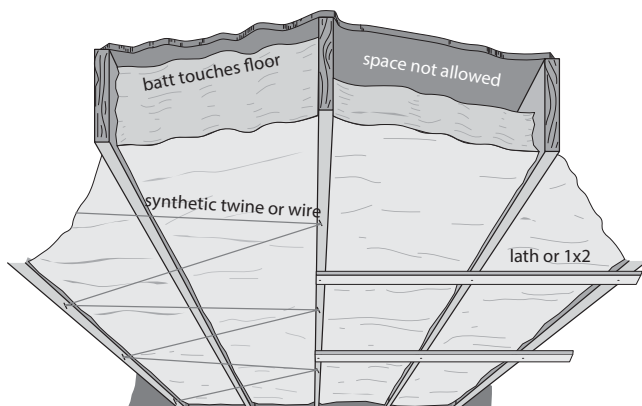

Floor insulating with batts: Use unfaced or encapsulated fiberglass batts, installed flush to the floor bottom to insulate floors.

6.3.4 Crawl-Space Wall Insulation

SWS Detail: 2.02 Moisture; 4.0402 Walls: 4.0402.1 Closed Crawl-space- Non-Foam Insulation; 4.0402.2 Closed Crawl-space-Rigid Foam Insulation; 4.02.3 Closed Crawl-space -SPF Insulation;

Crawl-space foundation insulation is allowed only when cost effective.

Materials for Crawl-space Insulation

Foundation insulation is usually installed on the inside of the foundation walls. Contractors undertake this retrofit for both energy savings and moisture control. Observe these insulation specifications for insulating foundation walls.

- Refer to manufacturer ESR to determine code compliance for foam insulation installation.
- Refer to SWS for additional requirements. *SWS 4.0402.3*
- Install SWS compliant non-foam insulation *SWS 4.0402.1*
- Install SWS compliant rigid foamboard. *SWS 4.0402.2*

Foam-insulated foundation wall: A 20-gauge galvanized-steel termite shield and a 10 mil ground moisture barrier protect the wood floor against termites and other pests.

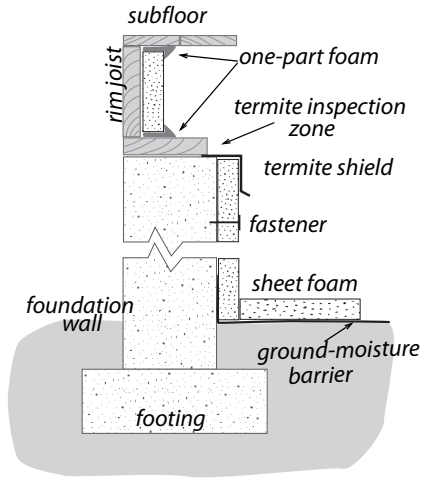

Safety and Durability

Consider the following issues when insulating foundation walls.

- ✓ Secure outdoor access hatches to foundation walls. If the foundation walls are insulated, also insulate any crawl-space access hatch with to the same R-value as the foundation wall.
- ✓ Remove obstacles and debris from crawl space.
- ✓ If an open combustion appliance is located in a crawl space, verify that appropriate combustion air is available.

- ✓ When insulating crawlspace walls, consult the local building inspector about acceptable ventilation options if in doubt.

In regions affected by termites, carpenter ants, and similar insects consider these suggestions.

- ✓ Leave a termite inspection zone.
- ✓ Apply insulation with moisture control measures, pesticide, or baiting.
- ✓ Consult with experts to ensure that the insulation, air sealing materials, and moisture barrier don't provide a conduit for insects to infest the wood floor.

Spray-foam-insulated foundation wall: Where termites aren't a threat, installers spray foam from the bottom of the foundation wall up to the top of the rim joist. If termites are a threat, leave a 3-inch inspection gap.

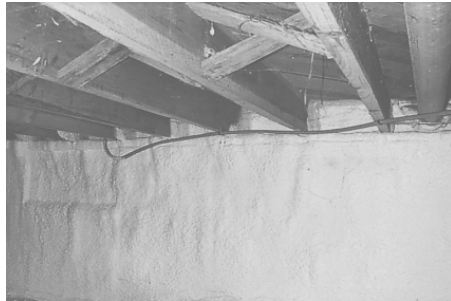

6.3.5 Basement Insulation

SWS Detail: 4.0402 Walls; 4.0402.4 Basements-without Ground Water; 4.0402.5 Basements with Ground Water

Before installing basement wall insulation, inspect for moisture problems and take appropriate action to solve moisture problems.

- ✓ Check for bulk water issues.
- ✓ Remove obstacles and debris from the basement.

- ✓ Repair structural cracks in foundation walls.
- ✓ Install a drainage system with a sump and outdoor drainage as appropriate to solve major moisture problems.

Frame-wall method: This method can be acceptable with meticulous air sealing to prevent basement air from circulating behind the wall. Exterior water drainage must be effective to prevent moisture problems in the basement.



Frame-Wall Insulation

The most common (although not the best way to insulate basement walls is to build a framed wall against the masonry wall and fill the wall with fiberglass batts. The frame wall is then covered with drywall.

Unfaced batts are the best choice of fiberglass insulation since they contain no vapor barrier to trap moisture. Moisture may escape from the wall in either direction: from outdoors in or indoors out.

- ✓ Insulate the rim joist and air seal it.
- ✓ Build the frame walls.
- ✓ Wall off the entire basement. If a mechanical room or other area won't be insulated, install an airtight block at the wall's edge to prevent basement air from circulating behind the insulated wall.
- ✓ Install drywall in an airtight manner on the walls and ceiling by applying sealant to the framing lumber around the sheet's perimeter.

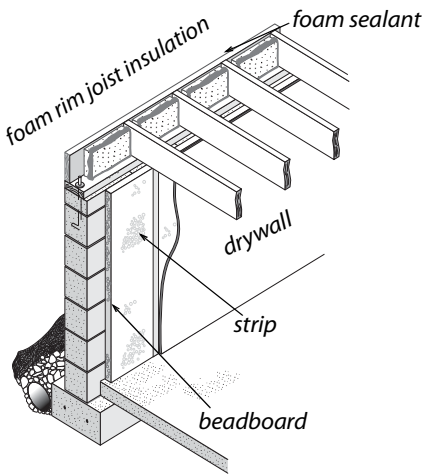

2-inch foam board with plywood strips: Installers fasten foam to the foundation wall using built-in strips. They then attach the drywall to the strips in the foam.

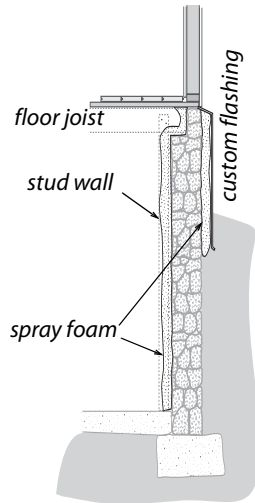

2-part foam sprayed on rubble masonry: Installers insulate rubble masonry walls on the interior or exterior with sprayed plastic foam. On the interior, they cover the foam with drywall.

Stripped Foam Basement Insulation

Polystyrene foam is an excellent choice for insulating smooth basement walls.

You can order either expanded polystyrene or extruded polystyrene equipped with grooves for fastening strips, spaced apart on ✓1-inch or 24-inch centers. Stripped foam sheets may be the eas-iest and most satisfactory way to insulate below-grade basement walls. Do these procedures to install 2-inch stripped foam on a foundation wall.

✓Install at least two mechanical fasteners, 24 inches from the bottom and top.

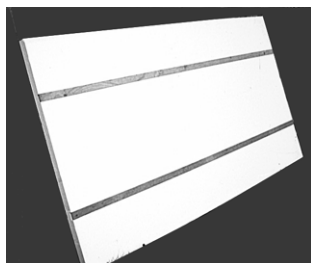
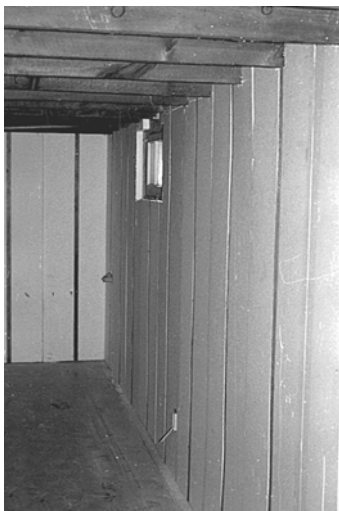

Installing stripped foam: Secure with mechanical fasteners

- ✓ When an electrical box is needed, install it between two sheets if possible. It is easier to run the wire between sheets than toward the center of a sheet. Install an electrical box backed by a piece of treated wood that sets the box out from the foam to accommodate the thickness of the wallboard that will be installed over the foamboard.

- ✓ Leave a half-inch gap at the bottom of the polystyrene sheets to run wire. Run the wire along the floor and up into the boxes. If flooding is a possibility, run the wire at the ceiling and down into boxes on the wall.
- ✓ Seal the bottom gap and other gaps in the foam sheeting with one-part foam.
- ✓ Glue and screw the drywall to each wooden strip.

Exterior Foam Foundation Insulation

Use durable water resistant ground contact rated insulation. For portions that are exposed above ground level you will need to provide mechanical and moisture protection such as sheet metal or fiberglass panels.

CHAPTER 7: WINDOWS AND DOORS

SWS Detail: 3.02 Shell Components; 3.0201 Windows; 3.0202 Doors

This chapter presents specifications and procedures for improving the airtightness and thermal resistance of windows and doors. Use lead-safe weatherization methods for all tasks relating to window and door weatherization, repair, and replacement.

7.1 STORM WINDOWS

SWS Detail: 3.0201.5 Interior fixed storm window installation; 3.0201.6 Interior operable storm window installation; 3.0201.7 Exterior fixed storm window installation; 3.0201.8 Exterior operable storm window installation

A storm window is an additional window installed outside or inside the primary window.

7.1.1 Exterior Aluminum Storm Windows

Exterior storm windows can save energy and preserve old worn primary windows from destructive weathering. They can be attached to exterior operable storm windows to the blind stop or exterior window casing of a double-hung window; or attach a fixed storm to any flat surface of a window frame or sash if the window is fixed or if a movable sash can support the extra weight.

- Choose operable storm windows to install on operable windows. Choose fixed storm windows to install on fixed windows or on sashes that open along with the movable primary window.
- If operable, make sure that the storm window opens and closes to allow the maximum amount of ventilation and egress area.
- Measure the storm window dimensions according to where the storm window will be attached.

- Storm-window frames should have sturdy corners so they don't rack out-of-square during transport and installation.
- Sashes must fit tightly in their frames.
- The gasket sealing the glass should surround the glass's edge.
- Consider selecting a hard-coat low-e glass for the storm window, which should face the primary window to protect the low-e coating.
- The storm window should be sized accurately and should fit tightly in the opening.
- The storm window's sashes should be removable from indoors for cleaning.

Aluminum exterior storm windows: They protect the primary window and add about an R-1 to the window assembly.

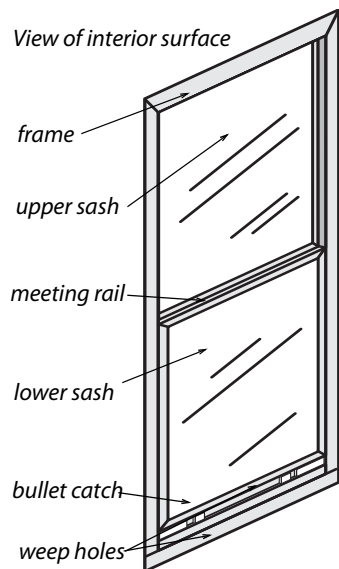

Installation of Exterior Storm Windows

Follow these guidelines when installing storm windows.

- ✓ Seal storm windows around the frame at time of installation with sealant tape or caulk.

- ✓ Do not allow the tape or caulk to interfere with the weep holes at the bottom of the frame. If weep holes aren't manufactured into new storm window, drill weep holes or leave at least 2 two-inch spaces in sealant to allow water on the sill to escape.
- ✓ Do not allow storm windows to restrict emergency egress or ventilation through movable windows.

7.1.2 Interior Storm Windows

SWS Details: 3.0201.5 Interior Fixed Storm Window Installation; 3.0201.6 Interior Operable Storm Window Installation

Interior storm windows are usually more airtight than exterior storm windows. Interior storm windows are usually a metal or plastic frame enclosing glazing.

Consider these specifications when selecting interior storm windows.

- Do not install fixed interior storm windows on egress windows.
- Interior storm windows should have an airtight edge seal to prevent warm moist air from passing by the interior storm window and condensing on the interior of the glass.
- Interior storm windows should be removable for storage.
- The home should have a safe place to store the storm windows seasonally.
- Consider using low-e glass or plastic for glazing to increase thermal resistance.

7.2 WINDOW REPAIR AND AIR LEAKAGE REDUCTION

SWS Detail: Window Airsealing; 3.0201.4 Glass Replacement; 3.0201.2 Window Sash Replacement; 3.0201.3 Window Sill Replacement

With the exception of broken glass or missing window panes, windows aren't often the major source of air leakage.

Window weatherstripping may solve comfort problems around windows, but it may not be cost effective.

7.2.1 Double-Hung Window Weatherization

Reglazing window sashes in a quality manner is time consuming. Re-glazing wood windows may not be a durable repair without thorough scraping, priming, and painting. Use lead-safe work practices when working on windows.

Repair measures may include the following.

- ✓ Replace missing or broken glass.
- ✓ Caulk the window frame where appropriate to prevent air leakage, condensation, and rain leakage.
- ✓ Replace missing or severely deteriorated window frame components only when necessary to preserve an ECM.

- ✓ Fill damaged wood with epoxy before priming and painting.
- ✓ Adjust window stops if gaps exist between the stop and jamb. Ensure that the window operates smoothly following adjustment.
- ✓ Weatherstrip large gaps between the sash and the sill or stops. Weatherstrip the meeting rails if needed.
- ✓ Replace or repair missing or non-functional top and side sash locks, hinges, or other hardware if this significantly reduces air leakage.

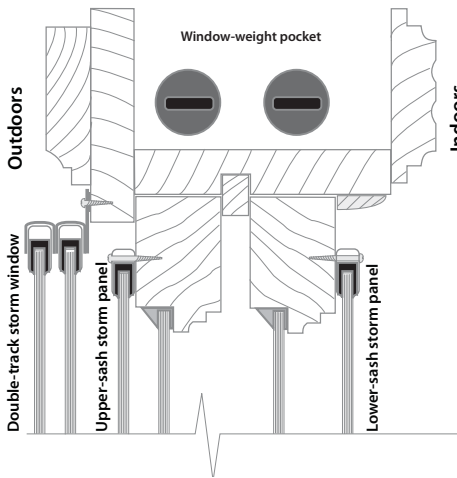

Optimized double-hung window: An exterior aluminum storm window plus storm window panels on the window sashes create triple glazing in this double-hung window.

7.2.2 Weatherstripping Double-Hung Windows

SWS Detail: 3.0201.1 Window Airsealing

Window weatherstripping is typically a comfort retrofit.

Paint is the primary obstacle when weatherstripping double-hung windows. Often the upper sash has slipped down, and is locked in place by layers of paint, producing a leaking gap between the meeting rails of the upper and lower sashes.

- ✓ To make the meeting rails meet again, either break the paint seal and push the upper sash up, or cut the bottom of the lower sash off to bring it down.

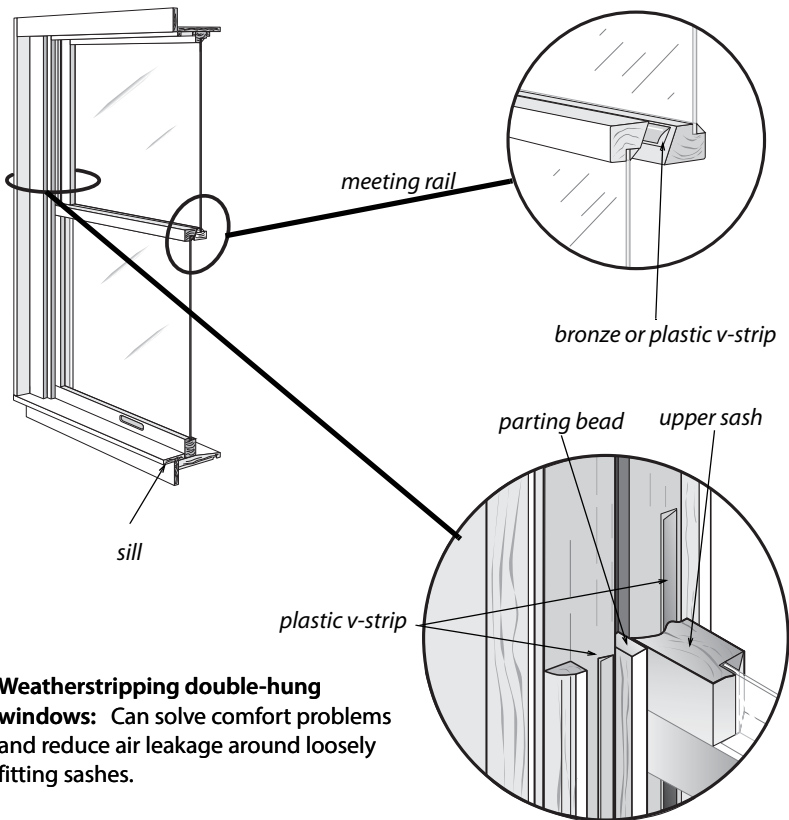

Weatherstripping double-hung windows: Can solve comfort problems and reduce air leakage around loosely fitting sashes.

- ✓ To lift the upper sash, cut the paint around its inside and outside perimeter. Use leverage or a small hydraulic jack to lift the sash. Jack only at the corners of the sash. Lifting in the middle can break the glass.
- ✓ Block, screw, or nail the repositioned upper sash into place.
- ✓ To weatherstrip the window, remove the lower sash. Cut the paint where the window stop meets the jamb so the paint doesn't pop off in large flakes as you pry the stop off.

Removing one stop is sufficient to remove the bottom sash.

- ✓ Scrape excess paint from the sashes and the window sill.
- ✓ Apply vinyl V-strip to the side jambs, and bronze V-strip to the meeting rail on the top sash. The point of the bronze V goes skyward. The weatherstrip is caulked on its back side and stapled in place, as shown in the illustration.

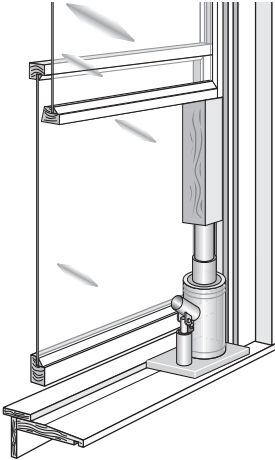

Lifting an upper window sash:
First cut paint away from around the sash inside and outside. Then lift with leverage or a jack.

7.3 WINDOW REPLACEMENT SPECIFICATIONS

Windows can only be replaced when the energy modeling software determines it is an ECM or it is an IRM to weatherization installed ECM.

The purpose of these specifications is to guide the selection and installation of replacement windows.

Existing window openings may have moisture damage and air leakage. Repair these conditions before or during window replacement.

Newly installed windows must meet AHJ code requirements, e.g., safety glass, egress, etc.

7.3.1 Window Energy Specifications

Installing new windows incurs a large labor expense so they should be as energy-efficient as budget allows.

1. Replacement windows must meet SHGC, U-value, and air leakage requirements of the work order. See SWS 3.0201.9.
2. Replacement windows facing east or west in air conditioned homes should have a solar heat-gain coefficient (SHGC) that is equal to or less than what is required by State standards.

	ACME Window Company EnerSaver 2010 Vinyl Frame Double Glazing - Argon Fill - Low E Horizontal Sliding Window
Energy Performance Ratings	
U-Factor (US/I-P) 0.32	Solar Heat Gain Coefficient 0.40
Additional Performance Ratings	
Visible Transmittance 0.54	Air Leakage (US/I-P) 0.3
Condensation 0.51	
<small>Manufacturer stipulates that these ratings conform to applicable NFRC procedures for determining whole product energy performance. NFRC ratings are determined for a fixed set of environmental conditions and specific product sizes. NFRC does not recommend any product and does not warrant the suitability of any product size. Contact the manufacturer for other performance information. www.nfrc.org</small>	

Example NFRC label: The key selection criteria for window shopping is displayed on the NFRC label.

7.3.2 Removing Old Windows

Remove existing windows without damaging the home’s interior finish, siding, exterior trim, or the water resistive barrier.

1. Follow EPA RRP requirements.
2. Remove window sashes, jambs, or siding, depending on the window-replacement method chosen.
3. Repair moisture damage to the rough opening before installing the new window.

To prevent water leakage in frame buildings, the win-dow must be integrated, if possible, into the home’s water resistive barrier (WRB).

7.3.3 Replacing Nailing-Fin Windows

Install replacement windows with nailing fins in the rough opening after removing the existing window frame and exterior trim. Fasten the nailing fins directly to the house's sheathing or framing, but support the window's weight on the sill with or without shims before fastening the window to the building.

Water-Resistive Barrier (WRB)

The WRB is the building's last defense against water. House wrap and asphalt felt are the most common WRBs. Window replacements that expose the home's WRB must incorporate the WRB in the window installation. Install a sill pan below the window and flashing on the side fins. Use flashing to connect the window opening to the WRB so water that penetrates the siding, trim, or window exits the building by way of the WRB.

Install replacement windows so water that penetrates the siding or trim drains to the outdoors. With proper flashing, the fins and flashing create a drainage system that drains water to the outdoors rather than relying on caulked siding and trim to prevent rain water from penetrating the building's surface.

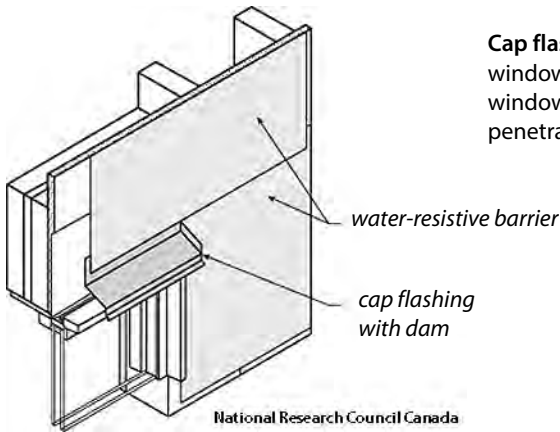

Cap flashing: Cap flashing at the window's head protects the window from rain water penetration.

Follow these steps to install a nailing-fin window in the rough opening.

1. At the sill, insert the flashing underneath the existing siding, over top of existing building paper, and under the bottom nailing fin of the window.
2. Use flat shims to provide a level surface and support under the vertical structural members of the new window frame. Do not allow the fins to support the window's weight.
3. Use fasteners with heads wide enough in diameter to span the holes or slots in the window fin.
4. Avoid over-driving the fasteners or otherwise deforming the window fin.
5. Flash the window around its perimeter with 15-pound felt, house wrap, or a peel-and-stick membrane.
 - a. Flashing procedures may vary. However, always install flashing materials to overlap like shingles.
 - b. Insert the new building paper or flashing underneath the existing siding and underneath existing building paper on the sides and top of the window opening.

6. Windows that are exposed to wind-driven rain or without overhangs above them or without WRB integration should have a rigid cap flashing to prevent rainwater from draining onto the window. The cap flashing should divert water away from vertical joints bordering the window with an overhang or dam.
7. Tuck the cap flashing up behind the WRB or exterior siding. Metal cap flashing must have downward bending lip of at least $\frac{1}{4}$ inch on the front and ends.
8. Thoroughly caulk all filler and trim pieces surrounding the replacement window.

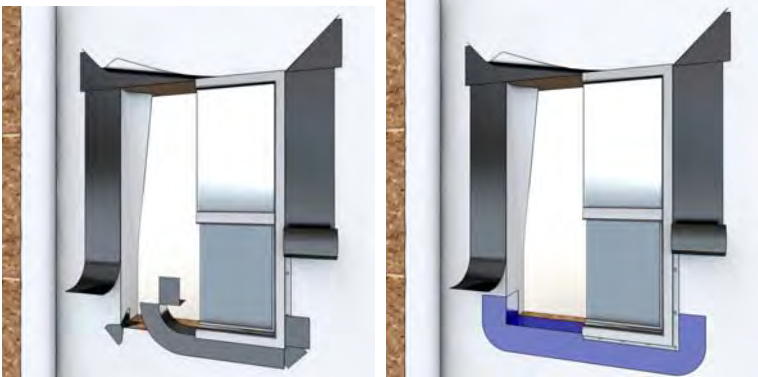

Flashing nail-fin windows: Installers place the window on and over the sill flashing. The side and top flashing cover the fastening fin. The two methods shown here are: using a flexible membrane (right) and using a bowtie-shaped flashing to underlay the corners when using a standard membrane.

7.3.4 Block-Frame or Finless Windows

Contractors install windows using a block-frame or finless installation when they can't remove the existing window frame

or in a masonry window opening. Block-frame windows rely on caulk or rigid flashing to create a weatherproof seal around the window perimeter.

Comply with the following requirements when installing block-frame or finless windows.

1. Block-frame or finless windows may require a sufficiently wide gap between the new window and the existing window frame or masonry opening to allow for the following.
 - a. Allowing for a slightly out-of-square opening.
 - b. Leveling the window.
 - c. Insulating the gap with foam.
2. Access the window weight cavities, remove the weights, fill the cavities with insulation, and seal the cavities.
3. Protect the existing sill with a metal or plastic sill pan or rigid sill flashing for drainage and to protect the existing sill that protrudes from the exterior wall. Or, install a new sill as part of the window replacement.
4. Support block frame or finless windows under the main vertical supports with shims to level the window.
 - a. Use flat shims for support if the sill surface is flat.
 - b. Use tapered shims or a sill angle for support if the sill surface is sloping.
5. Windows without fins must be secured to the rough opening within 4 inches of each side corner and a minimum 12 inches on center along the remainder of the frame with one of these fastening methods.
 - a. Screws fastened through the window frame.
 - b. Jamb clips or plates that are fastened first to the window and then to the opening in separate steps.

6. Fill any gaps over $\frac{3}{8}$ inch that are between the exterior siding and the block-frame window. Install backer rod in all exterior or interior voids over $\frac{3}{8}$ inch in depth or width before caulking.
7. If possible, flash block-frame windows between the opening and the replacement-window frame and extend the flashing out far enough to slip under or into the siding.
 - a. Tuck flashing behind the exterior siding at least 1 inch.
 - b. Sill and cap flashing should have a downward bending lip of at least $\frac{1}{4}$ inch on the front.

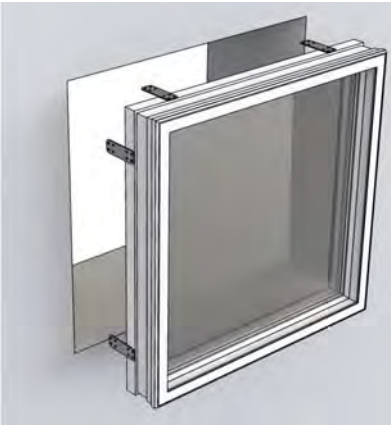

Block frame window installation:
Block-frame windows don't have a

7.3.5 Flush-Fin Window Replacement

Flush-frame windows are replacement windows that fasten to the window opening and mount directly over the flat siding surrounding the window opening. Replace windows in stucco walls using windows with flush fins that have no nail holes.

1. Support the replacement window on the existing sill with one of the following materials.
 - a. A flat or tapered continuous wood support.
 - b. Flat shims under the window's main vertical supports.
 - c. Tapered shims under the window's main vertical supports if the sill is sloping.
2. Apply a sealant that remains flexible to the back of the flush fin of the replacement window in order to seal it to the surface of the exterior wall. Interrupt the caulking at the bottom fin for one inch on each side of the window's weep holes.
3. Fasten the flush-fin window to the opening by driving screws through the replacement window frame.



Flush frame window: Flush frame windows have the fin at the exterior surface of the window and seal to a flat exterior surface like stucco.

7.4 WINDOW SAFETY SPECIFICATIONS

Windows have requirements for breakage resistance in areas that are prone to glass breakage, and for egress in bedrooms.

7.4.1 Windows Requiring Safety Glass

Safety glass is required in locations the IRC 2012 considers hazardous to the building's occupants. Safety glass must be laminated glass, tempered glass, organic coated glass, or annealed glass bearing a permanent label identifying it as safety glass, manufactured in compliance with CPSC 16 CFR 1201 or ANSI Z97.1.

Instead of safety glazing, glazed panels may have a protective bar installed on the accessible sides of the glazing 34 to 38 inches above the floor. The bar must be capable of withstanding a horizontal load of 50 pounds per linear foot without contacting the glass and be a minimum of 1¹/₂ inches in diameter.

Safety glass or a protective bar is required in the following hazardous locations.

- ✓ Glazing wider than 3 inches in entrance doors.
- ✓ Glazing in fixed and sliding panels of sliding doors and panels in swinging doors.

Safety glass around doors: A window near a door must be glazed with safety glass when the window is less than 24 inches from the door and less than 60 inches from the floor.

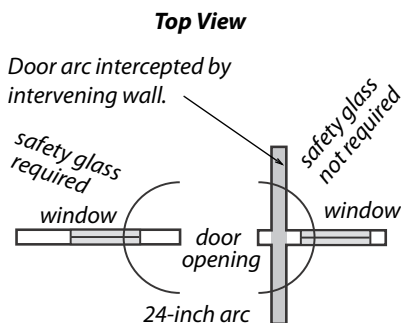

- ✓ Glazing in fixed or operable panels adjacent to a door where the nearest exposed edge of the glazing is within a 24-inch arc of the vertical edge of the door in a closed position and where the bottom edge of the glazing is less than 60-inches above the floor or walking surface. Exception: If there is an intervening wall or permanent barrier between the door and the glazing, safety glass isn't required.
- ✓ Glazing adjacent to the landing of the bottom of a stairway where the glazing is less than 36 inches above the landing and within 60 inches horizontally of the bottom tread.
- ✓ Glazing with a bottom exposed edge that is less than 36 inches above the walkway surface of stairways, landings, and ramps.
- ✓ Glazing in any portion of a building wall enclosing showers, hot tubs, whirlpools, saunas, steam rooms, and bathtubs where the bottom exposed edge is less than 5 feet above a standing surface or drain inlet.

Glazing in an individual fixed or operable panel that meets all of the following conditions must also have safety glass:

1. An exposed area of an individual pane greater than 9 square feet, and
2. An exposed bottom edge less than 18 inches above the floor.
3. An exposed top edge greater than 36 inches above the floor.
4. One or more walkways within 36 inches horizontally of the glazing.

7.4.2 Fire Egress Windows

Windows are the designated fire escape for bedrooms and should offer a minimum opening for a person's escape. If the window installation requires a code-approved egress window, observe these specifications.

1. Each bedroom must have one egress window.
2. Egress windows must provide an opening that is at least 20 inches wide and at least 24 inches high.
3. Egress windows must provide an opening with a clear area of at least 5.7 square feet except for below-grade windows, which must have at least 5.0 square feet of opening.
4. The finished sill of the egress window must be no higher off the floor than 44 inches.
5. You may install security bars, screens, or covers over egress windows as long as these security devices are easily removable from indoors.

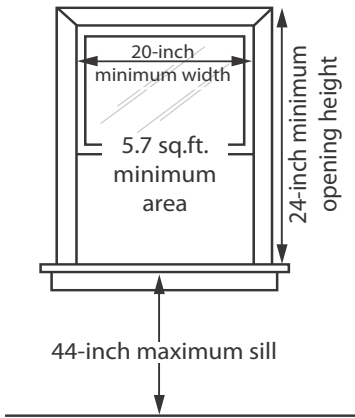

Egress windows: Windows for fire escape must be large enough and a convenient distance from the floor.

7.5 DOOR REPLACEMENT AND IMPROVEMENT

3.0202 Doors; 3.0202.2 Door Replacement

Exterior doors suffer a lot of wear because they function as entrances to buildings. Doors cannot be replaced utilizing DOE health and safety dollars.

Isolating garage from living space is required. When there is a door separating the living space from the garage, refer to SWS and ASHRAE Standards for isolation requirements.

7.5.1 Door Replacement

Door replacement may be completed as an efficiency measure if the cost is justified. Use RRP & LSW methods to ensure occupants and workers aren't exposed to lead dust during door repair measures.

Observe the following standards when replacing exterior doors.

- ✓ Door replacement selection must be in compliance with SWS and AHJ.
- ✓ Select no door glazing or door glazing with an appropriate solar heat-gain coefficient for the climate.

- ✓ Replace the existing door with an exterior-grade insulated door or a pre-hung insulated door.
- ✓ Install new door as outlined by manufacturer's specifications.
- ✓ Adjust the new threshold for proper fit and minimal air leakage at the door bottom.

7.5.2 Door Adjustment and Repair

Perform all door adjustments and repairs following EPA lead regulations.

Evaluating Exterior Doors

Before weatherstripping a door, evaluate the door's operation.

- Does the door bind or scrape against its jambs, indicating a need for hinge adjustment?
- Does the door close tightly and evenly against its stops or is there an uneven space between the door and stop when the door is latched?
- Can you move the latched door back and forth against its stops?

Fixing Binding Doors

- Adjust binding doors by moving the door within its opening. Moving the top and middle hinges in, or moving the bottom and middle hinges out moves the door's top latch-side corner upward and back toward the top hinge. Moving the top and middle hinges out drops the door down and moves the door away from the top hinge.
- If the hinges are loose, tighten the hinges and add longer screws if necessary.
- If the gaps at the top latch side corner are uneven, rotate the door in its opening by adjusting the hinges. Chisel the hinge mortises a little deeper or install cardboard shims between the hinges and door or jamb to move the door to create an even space around the door.
- If the house has settled and the opening is out-of-square, plane or power-sand the door so it closes without rubbing or binding against its jambs.
- If paint has built up and reduced the door's operating gap, plane or sand off the excess paint.

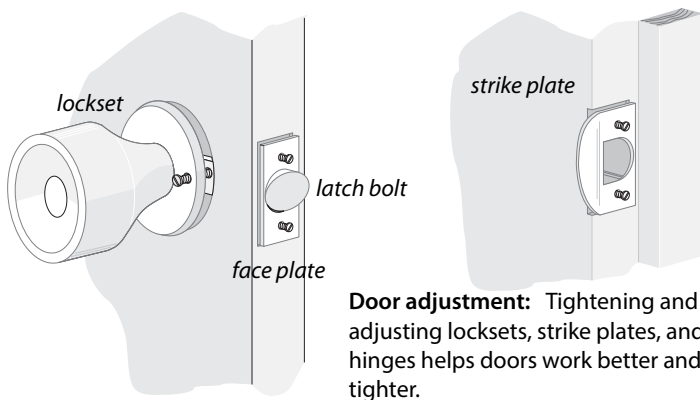

Adjusting Latches and Stops

If a door won't latch, inspect the door stops and weatherstripping to see if they're binding. If there's no obvious problem with the weatherstrip or stops, move the strike plate out slightly or use a file to remove a little metal from the strike plate to allow the latch to seat itself.

- ✓ Tighten loose door knobs, face plates, and strike plates.
- ✓ If the door is warped and doesn't fit well against its stops, adjust the stops by moving them against the door or planing them so door closes snugly against its stops.
- ✓ Move the strike plate to hold the door evenly against its stops if necessary. Use longer screws if you have to move the strike plate.

Weatherstripping Doors

Consider these suggestions when weatherstripping doors.

- ✓ Use a durable stop-mounted or jamb-mounted weatherstrip to seal the door's side jambs and head jamb.
- ✓ Seal the back of the weatherstrip to prevent air from leaking behind the weatherstrip.

- ✓ Install thresholds and door sweeps if needed to prevent air leakage at the door bottom. These air seals should not bind the door. Thresholds should be caulked underneath and on both sides of the door sill.
- ✓ Install corner seals to close the gaps at the bottom corners of the door jambs.
- ✓ Seal gaps between the stop and jamb with caulk.
- ✓ Install a door sweep if you don't install a door bottom.
- ✓ The door must operate smoothly in the locked position after you weatherstrip it.

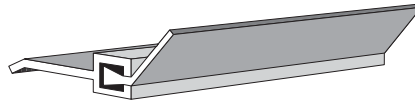

Vinyl flap weatherstrip is particularly flexible, allowing the door to remain sealed with seasonal movements of the door

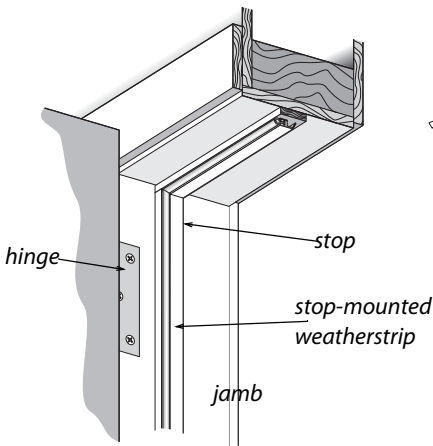

Silicone bulb weatherstrip is much more flexible than vinyl bulb and therefore seals better.



Bronze v-strip mounts on the door jamb and is very durable.

Weatherstripping doors: The three weatherstrips shown should be flexible enough to move with the door seasonally and maintain their seal as the door moves seasonally.

CHAPTER 8: HEATING AND COOLING SYSTEMS

This chapter discusses safety and energy-efficiency improvements to heating and cooling systems. It is divided into these main sections.

1. Essential combustion-safety testing
2. Heating-system replacement
3. Servicing gas and oil heating systems
4. Combustion venting
5. Heating distribution systems
6. Air-conditioning systems

IHCDA requires that weatherization agencies perform a combustion-safety evaluation as part of each weatherization work scope.

Qualified heating technicians should perform the installations, adjustments, and maintenance described in this chapter.

Important Note: Use manufacturer's specifications and instruction. Many of the specifications in this chapter assume that the manufacturer's instructions aren't available. In the absence of manufacturer's specifications, we offer specific guidance that experts and reviewers consider correct.

8.1 HVAC-SYSTEM COMMISSIONING & EDUCATION

HVAC commissioning is the process of inspecting, testing, a system and educating occupants, landlords, and building operators.

8.1.1 HVAC-System Commissioning

SWS Details: 5.0108 Equipment Installation; 5.0203 Equipment Installation

- ✓ Verify that the HVAC system works as the manufacturer, designer, and installer understand it should work, based on plans, specifications, and manufacturers' literature.
- ✓ Take appropriate measurements to verify the HVAC system works safely and efficiently.
- ✓ Verify that the building owner and operator understand the HVAC system's operation and has the necessary system documentation.
- ✓ Verify that the building owner and operator understand the procedures and schedule for routine maintenance.

8.1.2 Multi-Family HVAC-System Education

Multi-family buildings are complex systems of building envelopes and mechanical systems that harbor a variety of hazards. Educate occupants, landlords, and building operators about the health and safety hazards and the improvements that you make to mitigate these hazards.

- ✓ Explain equipment operation and maintenance (O&M).
- ✓ As appropriate, provide a O&M procedures manuals and manufacturers' equipment specifications.
- ✓ Instruct occupants or staff to remove combustible materials from near ignition sources.
- ✓ Inform occupants and staff about smoke alarms, carbon monoxide (CO) alarms, and combination alarms, and explain their functioning.

8.2 COMBUSTION-SAFETY EVALUATION

SWS Detail: 5.05 Combustion Safety; Also, adhere to BPI Standards

Combustion safety will be evaluated prior to shell work being performed, after each day of shell work, and upon final inspection at the completion of the job.

8.2.1 Combustion-Safety Observations

Make the following observations before testing to help you determine the likelihood of carbon monoxide (CO) and spillage problems.

- ✓ Recognize soot near the draft diverter, barometric damper, or burner of a combustion appliance as a sign that the appliance produces CO and spills combustion gases.
- ✓ Recognize that rust in a chimney or vent connector may also indicate spillage.
- ✓ Look for leaks, disconnections, and blockages in the venting system.
- ✓ Specify that workers seal all accessible return-duct leaks near combustion furnaces.
- ✓ Verify that the home has a working CO and smoke alarm.
- ✓ Inspect gas ovens and range burners for flame stability and test them for carbon monoxide.
- ✓ Evaluate combustion air requirements for all combustion appliances. If the equipment is lacking available combustion and ventilation air per National Fuel Gas Code (NFPA 54) make necessary modifications. Note: If combustion and ventilation air requirements are met, worst case draft testing and combustion analysis must still be performed to evaluate the effects of depressurization on the appliances.

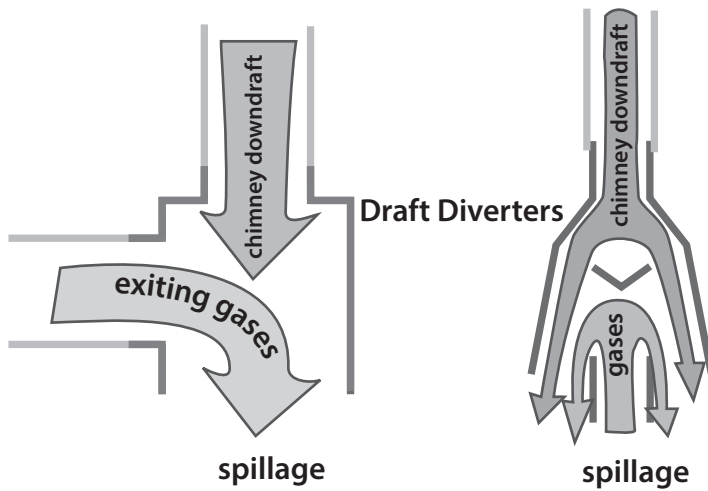

Draft-diverter spillage: Look for soot or corrosion near the draft diverter and also near the burner caused by spillage.

8.2.1 Leak Testing Gas Piping

Natural gas and propane piping systems may leak at their joints and fittings. Find gas leaks with an electronic combustible gas detector.

- ✓ Test all valves and joints with gas leak detector.
- ✓ Accurately locate leaks using a bubble solution.
- ✓ Repair or mark all gas leaks.
- ✓ Replace kinked, cracked, or corroded flexible gas connectors.
- ✓ Replace flexible gas lines manufactured before 1973. The manufacture date is stamped on a date ring attached to the flexible gas line or on the body of the hex nut.
- ✓ If no date is found, replace the gas line.

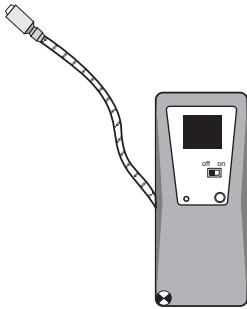

Gas sniffer: Use this device to detect the presence of combustible gases around fittings.

8.2.2 Carbon Monoxide (CO) Testing

SWS Detail: 2.01 Safety Devices; 5.05 Combustion Safety; Also, refer to BPI Standards

CO testing is essential for evaluating the safety of combustion and venting. Measure CO in the flue gas of every combustion appliance you inspect and service. Measure CO in ambient air in both the home and CAZ as part of inspection and testing of combustion appliances. We strongly recommend using a full-featured electronic combustion analyzer for flue-gas analysis during combustion safety testing.

Vent Testing for CO

Testing for CO in the appliance vent is a part of combustion testing that happens under worst-case conditions. CO production in the undiluted combustion byproducts should not exceed the following limits.

- Vented space heaters and water heaters: 100 ppm as measured or 200 ppm air-free.

- Furnaces or boilers: Maximum allowable CO level is 200 ppm as measured or 400 ppm air-free but only after all reasonable attempts have been made to reduce CO.
Although these numbers are code, it is highly recommended that a gas furnace be under 100 ppm as measured.

Ambient Air Monitoring for CO

To monitoring during combustion testing to ensure that CO in the combustion appliance zone (CAZ doesn't exceed dangerous levels is required.

- ✓ If ambient CO level in the CAZ exceeds 70 ppm, stop testing for your own safety. Communicate the situation clearly to the client, immediately evacuate the home, and contact appropriate personnel.
- ✓ If ambient CO level in the CAZ exceeds 35 ppm, but is less than 70 ppm, communicate the issue clearly and immediately to the client and suggest appropriate solutions. Inspect appliance.
- ✓ Ventilate the CAZ thoroughly before resuming combustion testing.
- ✓ Investigate indoor CO levels (which are greater than outdoor ambient levels) to determine their cause.

8.2.3 Worst-Case CAZ Depressurization Testing

SWS Detail: 5.05 Combustion Safety; 5.0501 Combustion Appliance Zones

CAZ depressurization is the leading cause of backdrafting and flame roll-out in furnaces and water heaters that vent into naturally drafting chimneys and venting systems.

Worst-case depressurization testing uses the home's exhaust fans, air handler, and chimneys to create worst-case depressurization in the CAZ. During this worst-case testing, you measure the CAZ pressure difference with reference to (WRT) outdoors and test for spillage.

Worst-case conditions do occur, and venting systems must exhaust combustion byproducts even under these extreme conditions. Worst-case vent testing exposes whether or not the venting system exhausts the combustion gases when the combustion-zone pressure is as negative as you can make it. A digital manometer is the best tool for accurate and reliable readings of combustion-zone depressurization.

Flame roll-out: A serious fire hazard can occur when the chimney is blocked, when the combustion zone is depressurized, or when the outdoor temperature is very cold.

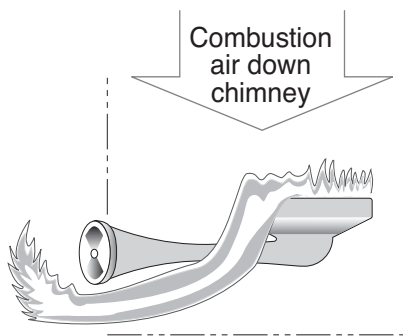

Take all necessary steps to reduce CAZ depressurization and minimize combustion spillage, based on your tests.

Worst-Case CAZ Depressurization Test

Follow the steps below to find the worst-case depressurization level in the combustion appliance zone (CAZ).

1. Turn off or set to pilot all vented combustion appliances.

2. Close all exterior doors, windows, and fireplace damper(s). Open all interior doors, including closet doors.
3. Turn off all operating exhaust appliances including clothes dryers and occupant ventilation fans.
4. Remove furnace filter. Be sure the filter slot is covered for the test.
5. Record the baseline pressure of the CAZ with reference to outdoors.
6. Turn on the clothes dryer and exhaust fans. (Clean clothes dryer filter.)
7. Open interior doors to negative-pressure zones (rooms with exhaust fans) and close doors to all other rooms off the main body. Use smoke or a manometer to verify room pressures across doors that separate sections of the main body or to a door you are just not sure about. Position doors to create the greatest negative pressure in the CAZ.
8. Open and close the CAZ door. Record the most negative pressure and note CAZ door position.
9. Turn on the furnace air handler at its highest normal operating speed. Reposition interior doors as appropriate. Smoke or pressure test doors to rooms with exhaust fans, returns or doors that you are not sure about. Position doors accordingly.
10. Open and close the CAZ door. Record the most negative pressure, and note CAZ door position.

Worst-case

depressurization: Worst-case depressurization tests identify problems that weaken draft and restrict combustion air. The testing described here is intended to reveal the cause of the CAZ depressurization and spillage.

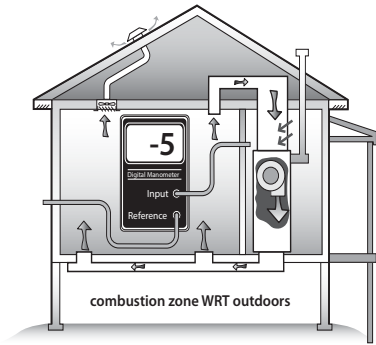

11. Adjust worst case CAZ depressurization to the baseline reading.
12. CAZ depressurization levels should be evaluated carefully. If the worst case CAZ depressurization for a draft water heater is -3 or greater with the blower off, it is highly recommended to replace the unit. If the CAZ depressurization of -3 or greater caused by the blower on, pressure balance/duct seal home before considering replacement.
13. Use the following troubleshooting chart to assist in specifying appropriate improvements when combustion appliances do not function properly when tested under worst case.
14. Auditors - Use the House Depressurization chart in Appendices to help predict potential post weatherization depressurization .
15. When unsure what to do, call INCAA training team.

Analyze the negative and positive pressures you measure in the CAZ to find solutions, using the troubleshooting table here.

CAZ Door Closed

Negative CAZ Pressure

Causes

- Stack effect
- Exhaust appliances in the CAZ or affecting the CAZ

Solutions

- Eliminate or reduce CFM of exhaust
- Isolate CAZ from the exhaust inside the building
- Isolate CAZ from the exhaust outside the building
- Install sealed-combustion furnaces and/or electric or power-vented water heaters
- Provide make-up air

Negative CAZ Pressure

Causes:

- Stack effect
- Return duct leakage in the CAZ

Solutions

- Seal return ducts in the CAZ

Positive CAZ Pressure

Causes

- Supply duct leakage in the CAZ

Solutions

- Seal supply ducts in the CAZ

Furnace Blower Off

Furnace Blower On

CAZ Door Open

Negative CAZ Pressure

Causes

- Stack effect
- Exhaust appliances

Solutions

- Eliminate or reduce CFM of exhaust
- Isolate combustion appliances
- Replace the combustion appliances
- Provide make-up air

Negative CAZ Pressure

Causes

- Stack effect
- Supply duct leakage to outdoors
- Interior door closure

Solutions

- Seal supply ducts
- Pressure relieve interior rooms

Positive CAZ Pressure

Causes

- Return duct leakage to outdoors
- Interior door closure

Solutions

- Seal return ducts
- Pressure relieve interior rooms

Furnace Blower Off

Furnace Blower On

Spillage and CO Testing

Next, verify that the combustion gases don't spill or contain excessive CO at worst case depressurization. Test each appliance in turn for spillage and CO as described below.

1. Check for flue gas flow in the vent. Feel the vent for heat. The vent should start warming within 5 seconds. If the vent remains cold, stop the test and investigate.
2. Detect spillage at the draft diverter of each combustion appliance in one of these ways.
 - a. Smoke generator smoke is repelled by spillage at the draft diverter.
 - b. A mirror fogs from spillage at the draft diverter.
3. If spillage in one or more appliances continues at worst-case depressurization for 2 minutes or more, take action to correct the problem.
4. Measure and record vent pressure in each category 1 appliance after 5 minutes.
5. Measure CO in the undiluted flue gases of each **vented space heater or water heater** after 5 minutes of operation at worst-case depressurization. If CO in undiluted flue gases is more than **100 ppm as measured or 200 ppm air-free** measurement, take action to reduce CO level.
6. Measure CO in the undiluted flue gases of each **furnace or boiler** after 5 minutes of operation at worst-case depressurization. If CO in undiluted flue gases is more than **100 ppm as measured or 200 ppm air-free** measurement, take action to reduce CO level. Maximum allowable CO in undiluted flue gases is 200 PPM as-

measured or 400 PPM air-free but only after all reasonable attempts have been made to reduce CO production.

8.2.4 Evaluating Combustion Air

SWS Detail: 5.0502 Combustion Air; 5.0502.1 Combustion Air-Fuel Fired Appliances

Combustion appliances need an air supply to support combustion and to balance the draft in natural draft chimneys. In most buildings, combustion air comes through building air leaks.

If workers seal the building tightly, they may reduce the available combustion air to a level that causes combustion problems. Evaluate combustion air using the following guidance.

8.2.5 Combustion and Ventilation Air

A combustion appliance zone (CAZ) is the space or room containing the combustion appliances. Evaluate all CAZs to determine whether proper combustion and ventilation air is available. Combustion air is supplied to the combustion appliance one of four ways.

1. To the CAZ directly through air leaks in the building.
2. To the CAZ through an intentional opening or openings between the CAZ and other indoor areas where air leaks replenish combustion air.
3. To the CAZ through intentional openings to the outdoors or ventilated intermediate zones like attics or crawl spaces.

4. Directly from the outdoors to the appliance. Appliances with direct combustion air supply are called direct-vent or sealed-combustion appliances.

Important Note: The National Fuel Gas Code presents two methods for calculating combustion air. The simpler of the two methods is The Standard Method. Apply the Standard Method when air leakage rate of the CAZ or house is sufficient. To use interior air for combustion and ventilation, the estimated natural air infiltration rate of the building must be no less than 0.4 ACH. If the air-leakage rate of the CAZ or structure is insufficient, then comply with the combustion and ventilation air requirements using the KAIR (Known Air Infiltration Rate) method per NFPA 54. However, neither method really predicts the amount of available combustion air due to the effects of exhaust fans and pressure imbalances from air handler operation. Perform a comprehensive worst case CAZ depressurization test to evaluate the combustion safety of the system.

8.2.6 The Standard Method

The Standard Method for determining the minimum volume communicating with the combustion appliances is 50 cubic feet of volume per 1000 BTUH of appliance input. This is sometimes referred to as the 1/20th rule. Required volume equals the total BTUH input of the appliances in the CAZ divided by 20.

EXAMPLE: A 100,000 BTUH FURNACE WITH A 40,000 BTUH WATER HEATER

$$100,000 + 40,000 = 140,000 \div 20 = 7,000 \text{ CUBIC FEET OF VOLUME}$$

8.2.7 Known Air Infiltration Rate (KAIR) Method

If you know the air infiltration rate of the structure, determine the minimum volume communicating with the CAZ by applying the infiltration rate to the calculation detailed in the NFPA

54. There are two equations for this method, one is for fan-assisted appliances and one is for draft-hood-type appliances.

Other than Fan Assisted Calculation

$$21 \text{ FT}^3 \div \text{ACH} \times (\text{BTUH INPUT} \div 1000) = \text{MINIMUM VOLUME}$$

EXAMPLE: HOUSE WITH AN INFILTRATION RATE OF 0.25 ACH AND A 100,000 BTUH FAN-ASSISTED FURNACE.

$$21 \text{ FT}^3 \div 0.25 = 84$$

$$84 \times (100,000 \text{ BTUH} \div 1,000) = \text{MINIMUM VOLUME}$$

$$84 \times 100 = 8,400 \text{ CUBIC FEET}$$

Fan-Assisted Calculation:

$$15 \text{ FT}^3 \div \text{ACH} \times (\text{BTUH INPUT} \div 1000) = \text{MINIMUM VOLUME}$$

EXAMPLE: HOUSE WITH AN INFILTRATION RATE OF 0.25 ACH AND A 100,000 BTUH DRAFT HOOD FURNACE.

$$15 \text{ FT}^3 \div 0.25 = 60$$

$$60 \times (100,000 \text{ BTUH} \div 1,000) = \text{MINIMUM VOLUME}$$

$$60 \times 100 = 6,000 \text{ CUBIC FEET}$$

8.2.8 Connecting Indoor Spaces

If the CAZ volume is less than the minimum, you may connect the CAZ to the adjacent space with combustion air openings sized and located in accordance with the following table.

Table 8-1: Combustion-Air Openings to Indoor Spaces: Location and Size

Location	Dimensions
<p>Combining spaces on the same story: Two openings, 1 within 12 inches of the top of the enclosure and 1 within 12 inches of the bottom of the enclosure</p>	<p>Minimum free area: 1 in² per 1000 Btuh with a minimum of 100 in²</p>
<p>Combining spaces in different stories: One or more openings in doors or floors</p>	<p>Minimum free area: 2 in² per 1000 Btuh Input</p>

Louvers and Grilles

Where louver and grille design and free area are not know, it shall be assumed that metal louvers have 75 percent free area and wood louvers have 25 percent free area.

8.2.9 Combustion Air from Outdoors

If the air leakage rate or the volume of the structure is determined to be insufficient, then outdoor combustion and ventilation air shall be provided through opening(s) to the outdoors.

- Combustion air from outdoors should only be added if the CAZ can be isolated from the rest of the dwelling.
- Consider mechanical combustion air systems when adding passive air openings from outdoors is impractical.

The openings used shall be sized and located in accordance with the following:

Table 8-2: Combustion-Air Openings to Outdoors: Location and Size

Location	Dimensions
Two direct vertical ducts to outdoors, 1 commencing within 12 inches of the top of the enclosure and 1 within 12 inches of the bottom of the enclosure	Minimum free area: 1 in ² per 4000 BTUH input for each opening
Two direct horizontal ducts to outdoors, 1 commencing within 12 inches of the top of the enclosure and 1 within 12 inches of the bottom of the enclosure	Minimum free area: 1 in ² per 2000 BTUH input for each opening
Single direct horizontal or vertical opening or duct to outdoors commencing within 12 inches of the top of the enclosure.	Minimum free area: 1 in ² per 3000 BTUH input and not less than the sum of the areas of all vent connectors in the space



Combustion analysis:
Measuring O₂ and CO during worst case is an effective way to evaluate the adequacy of combustion air.

Evaluating Combustion Air by Flue-Gas Analysis

Makeup air required for the operation of exhaust appliances needs to be considered when determining the adequacy of a space to provide combustion air.

- Per NFPA 54 2012: “Where exhaust fans, clothes dryers, and kitchen ventilation systems interfere with the operation of appliances, makeup air shall be provided.”
- Combustion analysis can be performed under natural conditions to assist in determining the adequacy of combustion air in the space.
- When exhaust fans are operating, combustion analysis can be used to determine if the operation of the appliances is affected.

8.2.10 Mitigating CAZ Depressurization and Spillage

If you find problems with CAZ depressurization or spillage, then you must back out of worst case to determine the cause.

Improvements to Mitigate CAZ Depressurization

If spillage is a result of depressurization, the problem will be a lack of make-up air for exhaust fans, duct leakage or door closure.

DOORS-DUCTS-FANS = The Three Headed Monster.

This list of improvements may solve spillage problems detected during the previous tests on a forced air heating system.

- ✓ Seal all supply ducts exterior to the dwelling.
- ✓ Address pressure imbalances due to interior door closure.
- ✓ Seal all return duct leaks in the CAZ or near the furnace.
- ✓ Isolate combustion appliances from exhaust fans, clothes dryers, and return registers by air sealing between the CAZ and zones containing these depressurizing devices.
- ✓ Reduce the CFM of exhaust appliances or eliminate unnecessary exhaust fans.
- ✓ As the last resort, replace the appliances with sealed-combustion direct vent units capable of withstanding the depressurization in the CAZ.

The addition of a passive combustion air opening to the exterior intended to address a makeup air problem is not allowed.

Chimney Improvements to Mitigate Spillage Problems

Suggest the following chimney improvements to mitigate spillage problems, detected during the previous testing.

- Remove chimney obstructions.
- Repair disconnections/leaks at joints and where the vent connector joins a masonry chimney.
- Ensure vent system complies with NFPA 54.
- If wind causes spillage, install a wind-dampening chimney cap.
- If heat and moisture have deteriorated the masonry chimney, install a new chimney liner.
- Increase the pitch of horizontal sections of vent.
- Increase the vertical rise of the vent connector, directly off the appliance vent collar.
- Replace a single wall vent connector with a double wall vent connector.

8.2.11 Combustion Air Related Solutions

If previously mentioned solutions are inadequate, consider replacing open combustion appliances with sealed combustion direct vent appliances.

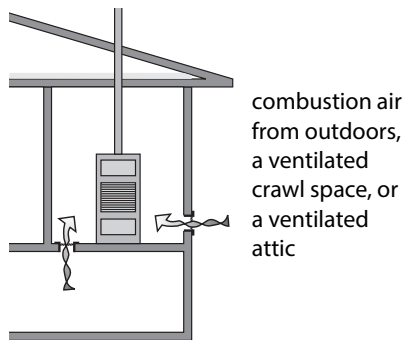
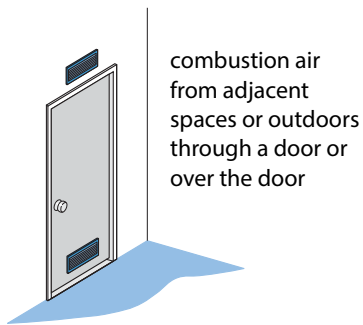

Combustion air options: Combustion air can be supplied from adjacent indoor spaces or from outdoors. High vents may occasionally compete with chimney draft for available air. Beware of drawing combustion air from wet crawl spaces. Pick your outdoor combustion-air location carefully to avoid pressurizing or depressurizing the CAZ.

Zone Isolation for Natural Draft Vented Appliances

If replacing natural draft appliances with sealed combustion isn't an option, isolating the CAZ improves the safety of natural-draft vented appliances in some cases. The CAZ is isolated if it receives combustion air only from outdoors or a ventilated intermediate zone. Inspect the CAZ for connections with the home's main zone and seal all connections.

1. Seal all connections between the isolated CAZ and the home. Examples include joist spaces, transfer grills, leaky doors, and holes for ducts or pipes.
2. Measure a base pressure from the CAZ to outdoors.
3. Setup house in worst case, and verify that the set-up doesn't affect the CAZ pressure.
4. Measure CO and O₂ at worst-case and evaluate combustion air.
5. If the CAZ to outdoors pressure changed during worst-case, continue to airseal the CAZ and retest as described in steps #2 and #3.
6. If the zone isolation fails, replace natural draft appliances with sealed combustion appliances.

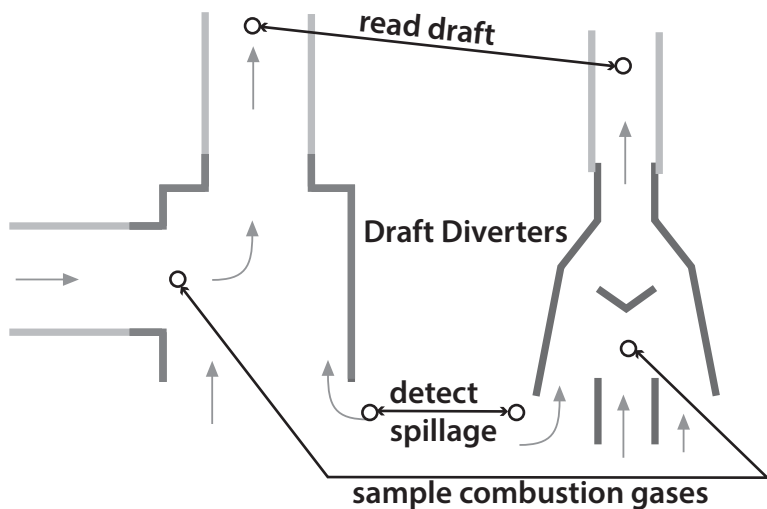

Testing locations: This illustration shows two draft diverters and the locations (circles) for draft testing, spillage detection, and combustion-gas sampling.

8.3 ELECTRONIC COMBUSTION ANALYSIS

The goal of a combustion analysis is to analyze combustion safety and efficiency. When the combustion appliance reaches steady state efficiency (SSE), you can measure its most critical combustion parameters. This information saves time and indicates what adjustments the service tech should make.

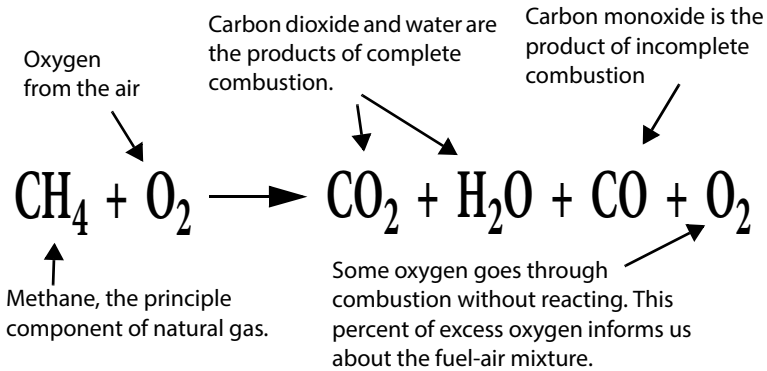

Modern combustion analyzers measure O₂, CO, and flue gas temperature. Some models also measure draft. Combustion analyzers also calculate combustion efficiency or steady-state efficiency (SSE) (two terms that mean the same thing)

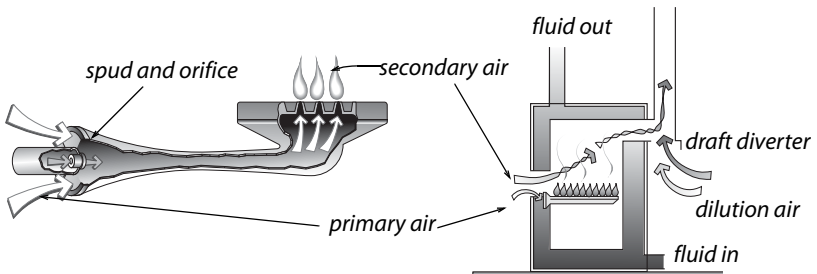

Natural-draft, open combustion gas burners: Combustion air comes from the indoors in open combustion appliances. Open-combustion burners use the heat of the flame to pull combustion air into the burner. Dilution air, entering at the draft diverter, prevents overfire draft from becoming excessive.



70+ Furnace: Sample flue gases within the draft diverter inside each exhaust port.



80+ Furnace: Measure draft and sample flue gases in the vent connector above the furnace.

8.3.1 Critical Combustion-Testing Parameters

These furnace testing parameters tell you how efficient and safe a combustion appliance currently is and how much you might be able to improve its efficiency. Use these measurements to analyze the combustion process.

Carbon monoxide (CO) (ppm): Poisonous gas indicates incomplete combustion. Modern combustion analyzers let you choose between an as-measured value or a calculated value that states the concentration of CO in theoretical **air-free** flue gases. Adjusting combustion to produce less than 100 ppm as measured or 200 ppm air-free is almost always possible with fuel-pressure adjustments, air adjustments, or burner maintenance.

Oxygen (percent): Indicates the percent of excess air and whether fuel air mixture is within a safe and efficient range. Combustion efficiency increases as oxygen decreases because excess air, indicated by the O_2 carries heat up the chimney. Percent O_2 may also indicate the cause of CO as either too

little or too much combustion air. T

Flue-gas temperature: Flue gas temperature is directly related to combustion efficiency. Too high flue gas temperature wastes energy and too low flue gas temperature causes corrosive condensation in the venting system.

Smoke number: For oil only, this measurement compares the stain made by flue gases with a numbered stain darkness rating called smoke number. Smoke number should be 1 or lighter on a 1 to 10 smoke scale.

Draft: The pressure in the chimney or vent connector.

Over fire draft: Used primarily with oil power burners.

Table 8-4: Combustion Standards for Gas Furnaces and Boilers

Performance Indicator	SSE 70+	SSE 80+	SSE 90+
Carbon monoxide (CO) (ppm as measured/air-free)	<200 ppm/ 400 ppm	<200 ppm/ 400 ppm	<200 ppm/ 400 ppm
Stack temperature (°F)	350°–475°	325°–450°	<120°
Oxygen (%O ₂)	5–10%	4–9%	4–9%
Natural gas pressure inches water column (IWC)	PMI	PMI	PMI
LP gas pressure	10–12 IWC	10–12 IWC	10–12 IWC
Steady-state efficiency (SSE) (%)	72–78%	78–82%	92–97%
Chimney draft (IWC, Pa)	–0.020 IWC –5 Pa	–0.020 IWC –5 Pa	0.100– 0.250 IWC +25–60 Pa
* pmi = per manufacturer’s instructions Use these standards also for boilers except for temperature rise.			

Table 8-5: Carbon Monoxide Causes and Solutions

Cause	Analysis / Solution
Flame smothered by combustion gases.	Chimney backdrafting from CAZ depressurization or chimney blockage.
Burner or pilot flame impinges.	Align burner or pilot burner. Reduce gas pressure if excessive.
Inadequate combustion air or too rich fuel-air mixture.	O ₂ is <6%. Gas input is excessive or combustion air is lacking. Reduce gas or add combustion air.
Blower interferes with flame.	Inspect heat exchanger. Replace furnace or heat exchanger.
Primary air shutter closed.	Open primary air shutter.
Dirt and debris on burner.	Clean burners.
Excessive combustion air cooling flame.	O ₂ is >10%. Increase gas pressure.

8.4 HEATING SYSTEM REPLACEMENT

SWS Detail: 5.0108 Equipment Installation; 5.88 Special Considerations; 5.8801 Equipment Removal; 5.8801 Decommissioning

This section discusses replacing combustion furnaces and boilers. We'll also discuss gas heating replacement and oil-heating replacement specification

8.4.1 Furnace or Heat Pump Replacement

This section discusses air handlers of combustion furnaces and heat pumps. Successful air handler replacement requires selecting the right heating and cooling input, blower model, and blower speed. The installation must include making repairs to ducts and other remaining components, and testing to verify the new air handler operates correctly.

Preparation for Replacement

- ✓ Recover refrigerant in the existing heating-cooling unit according to EPA regulations.
- ✓ Disconnect and remove the furnace or heat pump, attached air conditioning equipment, and other materials that won't be reused.
- ✓ Transport these materials off the client's property to a recycling facility.
- ✓ Verify that all accessible ducts were sealed as part of the furnace's installation, including the air handler, the plenums, and the branch ducts.

Equipment Selection

- ✓ Evaluate the building to determine the correct size of the furnace or heat pump, using ACCA Manual J or equivalent method. Manual J calculations for heating and cooling (in the case of heat pump replacement) are required to be in the completed client file.
- ✓ Select the smallest BTUH output furnace that exceeds your heat loss calculation and that your preferred manufacturer offers.
- ✓ Select the heating/cooling equipment using ACCA Manual S or equivalent method along with manufacturers' air-handler specifications. Consider blower airflow requirements for air conditioning (in addition to heating) if the new unit includes central air conditioning.

- ✓ Select the supply and return registers using ACCA Manual T or equivalent method.
- ✓ Ducts should be sized using ACCA Manual D or equivalent.

Air-Handler Installation

- ✓ The filter must be easy to replace and in a user friendly location.
- ✓ The filter retainer must hold the filter firmly in place and must have a cover if a filter slot exists.
- ✓ The filter must provide complete coverage of blower intake or return grille. The filter housing and restraint must not permit air to bypass the filter.
- ✓ If flue-gas temperature or supply air temperature are unusually high, check static pressure, fuel input, or electrical input.
- ✓ Attach the manufacturer's literature, including operating manual and service manual, to the furnace or heat pump.

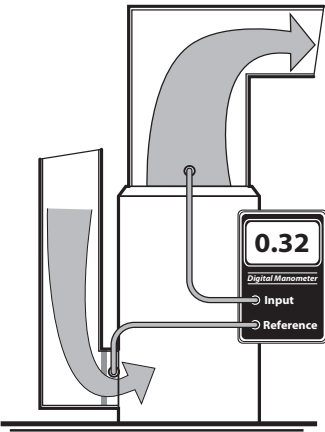

Static pressure and temperature rise: Measure static pressure and temperature rise across the new air handler to verify that the duct system isn't restricted. The correct airflow, specified by the manufacturer, is necessary for high efficiency.

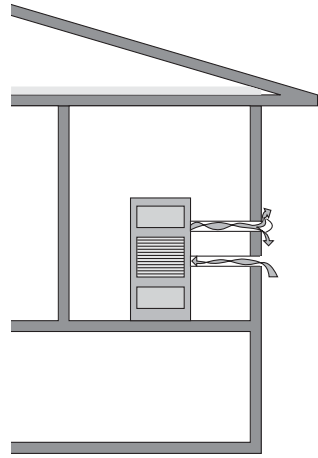

Sealed combustion heaters: Sealed-combustion furnaces prevent the air pollution and house depressurization caused by some open-combustion furnaces.

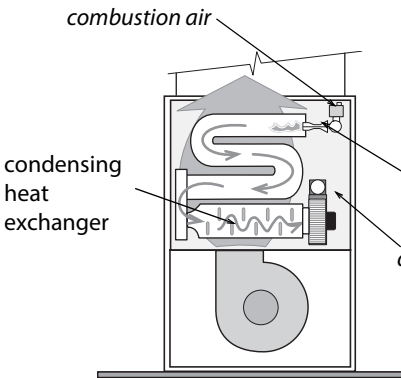

90+ Gas furnace: A 90+ furnace has a condensing heat exchanger and a stronger draft fan for pulling combustion gases through its more restrictive heat exchanger and establishing a strong positive draft.

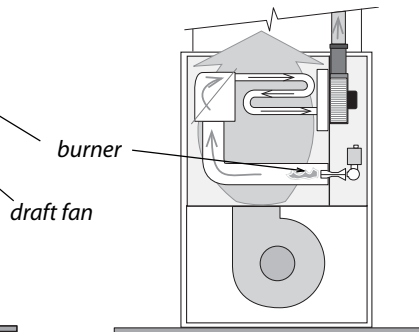

80+ Gas furnace: An 80+ furnace has a restrictive heat exchanger and draft fan, but has no draft diverter and no standing pilot light.

Supporting Air Handlers

Support the new air handlers using these specifications.

- Support horizontal air handlers from below with a non-combustible, water-proof, and non-wicking material. Or support the horizontal air handler with angle iron and threaded rod from above.
- Support upflow air handlers with corner support legs, bricks, or pads from below when necessary to hold it above a damp basement floor.
- Support downflow air handlers with a strong, airtight supply plenum. Insulate this supply plenum to minimize energy loss.

8.4.2 Gas-Fired Heating Installation

SWS Detail: 5.05 Combustion Safety; 5.0108 Equipment Installation; 5.0203 Equipment Installation; 5.0108.4 Furnaces

The goals of gas appliance replacement are to save energy and/or improve heating safety. The heating replacement project should produce a gas fired heating system in virtually new condition, even though existing components like the gas lines, chimney, pipes, or wiring may remain.

Include maintenance, repair, or replacement of existing components as part of the installation. Analyze design defects in the original system, and correct the defects during the heating system's replacement.

- If possible, install a condensing sealed combustion direct vent furnace or boiler with a 90+ AFUE.
- The new installation requires it to be Energy Star certified or equivalent.
- Install new gas fired unit with adequate clearances to allow maintenance.

- Follow the manufacturer's installation instructions along with NFPA 54 to ensure a proper installation.
- To help ensure compliance with Indiana Wx standards, Indiana's New Furnace Installation Inspection form must be completed prior to the start of shell work on the dwelling. The completed form is to be included in the client file.

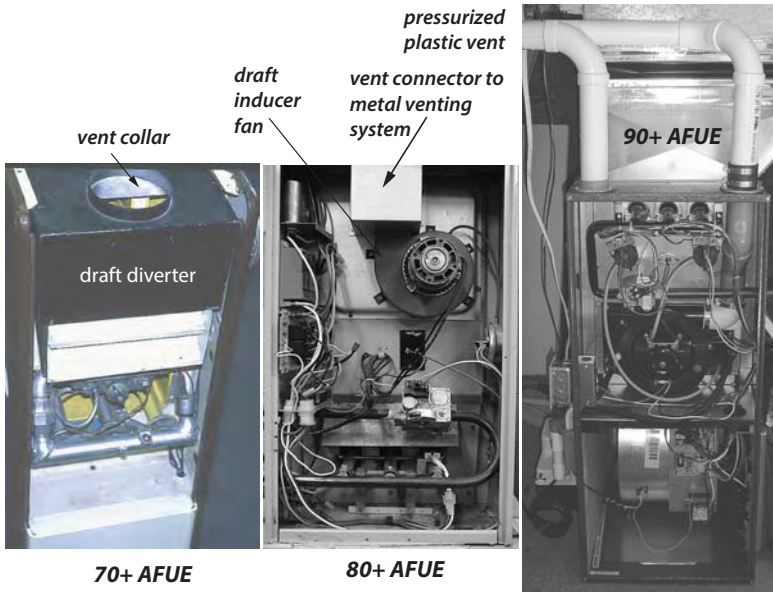

Gas furnace evolution: Energy auditors should be able to identify the 3 types of gas and propane furnaces. Only the 90+ AFUE furnace has a pressurized vent. The two earlier models vent into traditional natural-draft chimneys.

Testing New Gas Fired Heating Systems

- ✓ Do a combustion test and adjust fuel-air mixture to minimize O_2 . However don't allow CO beyond 100 ppm as measured or 200 ppm air-free with this adjustment.
- ✓ Verify that the gas water heater vents properly after installation of a sealed combustion direct vent or horizontally vented furnace or boiler.

Install a chimney liner if necessary to provide right-sized venting for the water heater.

8.4.3 Combustion Boiler Replacement

SWS Details: 5.02 Hydronic; 5.0203 Equipment Installation; 5.0203.1 Boilers; 5.05 Combustion Safety

Technicians replace boilers as an energy conservation measure or for health and safety reasons.

All new boiler installations must be Energy Star certified.

Boiler piping and controls present many options for zoning, boiler staging, and energy-saving features. Dividing homes into zones, with separate thermostats, can significantly improve energy efficiency compared to operating a single zone.

Follow these specifications when recommending a replacement boiler.

Design

A boiler's seasonal efficiency is more sensitive to correct sizing compared to a furnace.

- ✓ Determine the correct size of the boiler, using ACCA Manual J and considering the installed radiation surface connected to the boiler.
- ✓ Consider weatherization work that reduced the heating load serviced by the previous boiler when sizing the new boiler.
- ✓ Size new radiators according to room heat loss and design water temperature.
- ✓ Specify radiator temperature controls (RTCs) for areas with a history of overheating.

- ✓ A functioning pressure-relief valve, expansion tank, air-excluding device, back-flow preventer, and an automatic fill valve must be part of the new hydronic system.

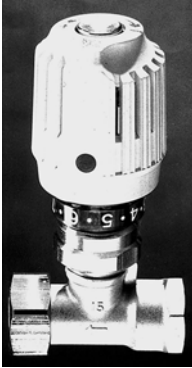

Radiator temperature control:
RTCs work well for controlling room temperature, especially in overheated rooms.

Pump and Piping

- ✓ Verify that all supply piping is insulated with foam or fiberglass pipe insulation.
- ✓ Suggest that the pump be installed near the downstream side of the expansion tank to prevent the suction side of the pump from depressurizing the piping, which can pull air into the piping system.
- ✓ Replace the expansion tank, unless it's the correct size for the new system. Adjust the expansion tank for the correct pressure during boiler installation.
- ✓ Extend new piping and radiators to conditioned areas, like additions and finished basements, which are currently heated by space heaters.

Controls

- ✓ Maintaining a low-limit boiler-water temperature is wasteful. Boiler controls should cold-start the boiler, unless the boiler is used for domestic water heating.
- ✓ For large boilers, install reset controllers that adjust supply water temperature according to outdoor temperature and

prevent the boiler from firing when the outdoor temperature is a sufficient temperature so that heat isn't needed.

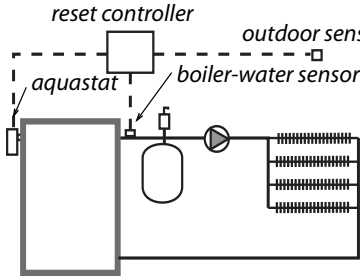

Reset controller: This control adjusts circulating-water temperature depending on the outdoor temperature.

- ✓ Verify that return water temperature is above 130° F for gas and above 150° F for oil, to prevent acidic condensation within the boiler, unless the boiler is designed for condensation. Install piping bypasses, mixing valves, primary/secondary piping, or other strategies to prevent condensation within a noncondensing boiler.

Combustion Testing

- ✓ Inspect the chimney and upgrade it if necessary.
- ✓ Verify that flue-gas oxygen and temperature are within the ranges specified in these two tables.

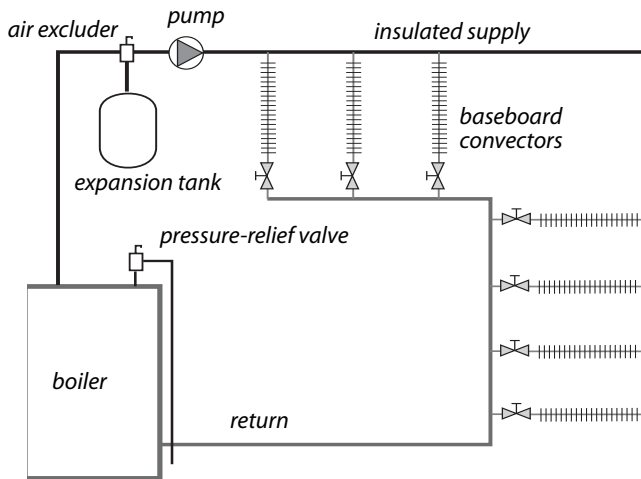

Simple reverse-return hot-water system: The reverse-return method of piping is the simplest way of balancing flow among the heat emitters.

Steam Boilers

Steam-boiler performance depends heavily on the adequacy of the existing steam distribution system. The boiler installer should know how the distribution system performed when it was connected to the old boiler.

The new boiler's water line should be at the same height as the old boiler's water line, or the installers should know how to compensate for the difference in water-line levels.

8.4.4 Oil-Fired Heating Installation

SWS Detail: 5.05 Combustion Safety; 5.0504 Fuel Delivery; 5.0504.2 Oil Piping; 5.0503.1 Fuel Fired Appliance Venting; 5.8801 Decommissioning

Oil heating replacement should provide an oil-fired heating system in virtually new condition, even though components like the oil tank, chimney, piping, and wiring may remain in place.

Any maintenance, repair, or replacement for these remaining components should be part of the replacement job. Analyze design defects of the original system, and correct them during the heating-system replacement.

- ✓ New oil fired furnaces must be Energy Star certified.
- ✓ New boilers must be Energy Star certified.
- ✓ Install new oil-fired furnaces and boilers with adequate clearances to facilitate maintenance.
- ✓ Inspect the existing chimney and the vent connector. Replace the vent connector with Type L double-wall vent pipe if necessary.
- ✓ Install a stainless steel chimney liner if necessary.

Oil heating system:
Components of an oil heating system may need replacement, repair, or cleaning during replacement of the furnace or boiler.

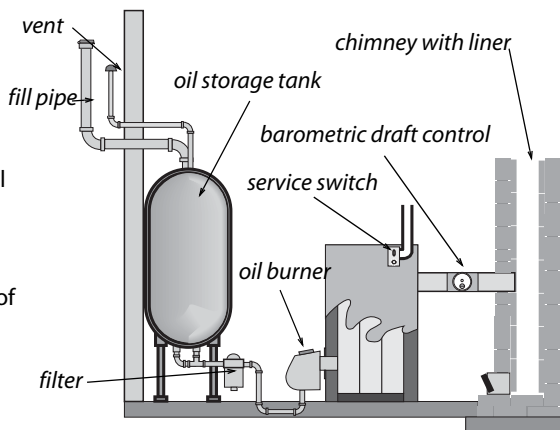

- ✓ Verify that the clearances between the vent connector and nearby combustibles are adequate.
- ✓ Install a new fuel filter, and purge the fuel lines as part of the new installation.

- ✓ Consider dual-filtration on systems with nozzle sizes smaller than .65 gph.
- ✓ If required, install a new barometric damper in the vent if the old damper shows any sign of wear.

Oil Combustion Controls

- ✓ Verify that the presence of a functioning emergency shut-off for emergencies and service work. Inform clients of its function for emergencies only.
- ✓ Look for a control that interrupts power to the burner in the event of a fire.
- ✓ Measure the transformer voltage to verify that it complies with the manufacturer's specifications.
- ✓ Measure the control circuit amperage, and adjust the thermostat's heat anticipator to match the amperage. Or follow the thermostat manufacturer's instructions.

Testing New Oil-Fired Heating Systems

- ✓ Verify that the oil pressure matches the manufacturer's specifications, but isn't less than 100 psi.
- ✓ If the flue-gas temperature is too high, adjust oil pressure per manufacturer's instructions or replace nozzle as necessary to produce the correct oil input (gpm) and flue-gas temperature.
- ✓ Verify that the spray angle and spray pattern fit the size and shape of the combustion chamber.
- ✓ As appropriate, adjust the barometric damper to achieve proper over-fire draft per manufacturer's instructions.
- ✓ Adjust oxygen, flue-gas temperature, and smoke number to comply with manufacturer's specifications. Smoke number should be zero on all modern oil-fired equipment.

8.4.5 Evaluating Oil Tanks

Inspect the oil tank, and remove dirt and moisture at bottom of the tank. Verify that the oil tank and oil lines comply with NFPA 31

Inspecting Above-Ground Oil Tanks

Indoor oil leaks are usually accompanied by strong petroleum smells. Inspect the oil tank as well as all the oil piping between the oil tank and the oil-fired furnace.

See NFPA 31 for detail.

Advice for Below-Ground Oil Tanks

Leaky below-ground oil tanks are a financial problem and a major environmental problem. If you encounter a below ground oil take, have it inspected by a certified professional.

8.5 COMBUSTION SPACE HEATER REPLACEMENT

SWS Detail: 5.05 Combustion Safety

Space heaters are inherently more efficient than central heaters, because they have no ducts or distribution pipes.

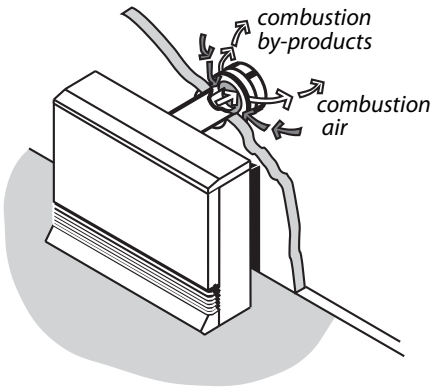

Sealed-combustion space heater:
Sealed-combustion space heaters draw combustion air in, using a draft fan.

Space heater controls: Many modern energy-efficient space heaters have programmable thermostats as a standard feature.

Weatherization agencies replace primary vented space heaters as an energy conservation measure or for health and safety reasons. Choose a sealed combustion direct vent space heater. Inspect existing space heaters for health and safety problems.

- ✓ If power outages are common, select a space heater that operates without electricity.
- ✓ Follow manufacturer’s venting instructions precisely.
- ✓ Don’t vent sealed combustion or induced-draft space heaters into naturally drafting chimneys.

- ✓ Verify that flue-gas oxygen and temperature are within the ranges.
- ✓ Install the equipment per manufacturer's specifications.

8.5.1 Space Heater Operation

Inform the client of the following operating instructions.

- ✓ Don't store any objects near the space heater.
- ✓ Don't use the space heater to dry clothes or for any purpose other than heating the home.
- ✓ Don't allow anyone to lean or sit on the space heater.
- ✓ Don't spray aerosols near the space heater.

8.5.2 Unvented Space Heaters

SWS Detail: 5.05 Combustion Safety

Unvented space heaters include ventless gas fireplaces and gas logs installed in fireplaces previously designed for wood burning or coal burning. The unvented space heaters and fireplaces create indoor air pollution because they deliver all their combustion byproducts to the indoors.

If client is using an unvented space heater as a primary source of heat, replace it with a vented appliance.

DOE forbids unvented space heaters as primary heating units in weatherized homes. However, unvented space heaters may be used as secondary heaters, under these requirements and the requirements outlined in the Indiana Unvented Space Heater form.

1. The heater must conform to the safety standards of ANSI Z21.11.2.
2. The heater must have an input rating less than 40,000 BTUH and be located only in a common area(See #7).
3. The heater must be equipped with an oxygen-depletion sensing shut-off system.
4. The room containing the heater must have adequate combustion air.
5. CO production from unvented space heaters shall not exceed 200 ppm air free or 100 ppm as measured.
6. Home must have adequate ventilation.
7. IHCDA does not allow space heaters to be left in bedrooms and bathrooms.

8.6 GAS BURNER SAFETY & EFFICIENCY SERVICE

Gas burners should be inspected and maintained during a service call. These following specifications apply to gas furnaces, boilers, water heaters, and space heaters.

8.6.1 Combustion Efficiency Test for Furnaces

Perform the following procedures at SSE to verify a furnaces acceptable operation.

Perform combustion testing with an electronic flue gas analyzer that documents accurate combustion air temperature so that net stack temperature is calculated correctly.

- Measure temperature rise (supply minus return temperatures). Temperature rise should be within the manufacturer's specifications for the furnace.

- Recommended flue-gas temperatures depend on the type of furnace and are listed in the table titled.
- Clock the gas meter to verify furnace input and adjust gas pressure as needed to satisfy the requirement of input being within 5% of the rated input. It is not allowable to go over the input rating.

8.6.2 Inspecting Gas Combustion Equipment

Inspect all gas-fired furnaces, boilers, water heaters, and space heaters according to these steps. For more complete information, follow the Indiana Inspection form.

- ✓ Look for soot, melted wire insulation, and rust in the burner and manifold inside and outside the burner compartment. These signs indicate flame roll-out, combustion gas spillage, CO, and incomplete combustion.
- ✓ Inspect the burners for dust, debris, misalignment, flame-impingement, and other flame-interference problems. Clean, vacuum, and adjust as needed.
- ✓ Inspect the heat exchanger for cracks, holes, or leaks.
- ✓ Verify that furnaces and boilers have dedicated circuits with safety shutoffs nearby. Verify that all 120-volt wiring connections are enclosed in covered electrical boxes.
- ✓ Verify that pilot is burning (if equipped) and that main burner ignition is satisfactory.
- ✓ Check venting system for proper diameter and pitch.
- ✓ Check venting system for obstructions, blockages, or leaks.
- ✓ Observe flame characteristics. Flames should be blue and well shaped. If flames are white or yellow, the burner may suffer from faulty combustion.

8.6.3 Testing and Adjustment

The goal of these measures is to minimize carbon monoxide (CO), stabilize flame, and verify the operation of safety controls.

- ✓ Do an electronic combustion analysis and note the oxygen, CO, CO₂, steady state efficiency and flue-gas temperature.
- ✓ Test for spillage and measure draft. Take action to improve the draft if it is inadequate because of improper venting, obstructed chimney, leaky chimney, or depressurization.
- ✓ Adjust gas input as needed
- ✓ For programmable thermostats, read the manufacturer's instructions about how to control cycle length

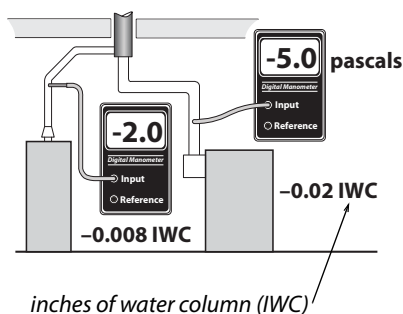

Measuring draft: Measure chimney draft downstream of the draft diverter.

Burner Cleaning

Clean and adjust the burner if any of these conditions exists

- CO is greater than 25 ppm as measured or greater than expected for that brand of furnace.
- You see indicators of soot or flame roll-out.
- Burners are visibly dirty.
- The appliance hasn't been serviced for two years or more.

Maintenance and Cleaning

Gas-burner and gas-venting maintenance should include the following measures.

- ✓ Remove causes of CO and soot, such as over-firing, closed primary air intake, flame impingement, and lack of combustion air.
- ✓ Remove dirt, rust, and other debris that may be interfering with the burners. Clean the heat exchanger if there are signs of soot around the burner compartment.
- ✓ Seal leaks in vent connectors and chimneys.

8.7 OIL BURNER SAFETY AND EFFICIENCY SERVICE

These procedures apply to oil-fired furnaces, boilers, and water heaters.

Oil burners require annual maintenance to maintain acceptable safety and combustion efficiency. Use combustion analysis to evaluate the oil burner and to guide maintenance and adjustment. Use other test equipment as discussed to measure other essential operating parameters and to make adjustments as necessary.

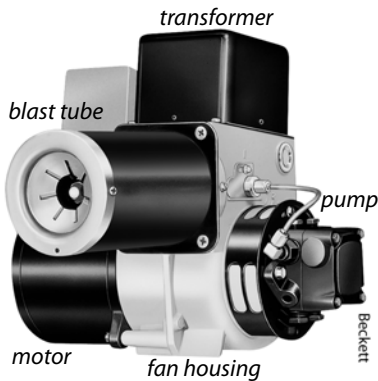

Oil burners: Oil burners are power burners that atomize the oil by pumping it through a nozzle. A blower forces combustion air into the oil mist. Electrodes powered by a transformer light the mixture.

8.7.1 Oil Burner Testing and Adjustment

SWS Detail: 5.05 Combustion Safety

Unless the oil-fired heating unit is very dirty or disabled, technicians should do combustion testing and adjust the burner for safe and efficient operation.

Combustion Testing and Adjustment

Combustion testing is essential to understanding the current oil burner performance and potential for improvement.

- ✓ Sample the undiluted flue gases with a smoke tester, after reading the smoke tester instructions. Compare the smoke smudge left by the gases on the filter paper with the manufacturer's smoke-spot scale to find the smoke number.
- ✓ If the smoke number is higher than 3, take steps to reduce smoke before sampling the gases with a combustion analyzer to prevent the smoke from fouling the analyzer.
- ✓ Sample undiluted flue gases between the barometric draft control and the appliance. Analyze the flue gas for O_2 ,

flue-gas temperature, CO, and steady-state efficiency (SSE).

- ✓ Measure the draft over the fire inside the firebox (overfire draft) through a plug in the heating unit.
- ✓ A flue gas temperature more than 450° F indicates that a clean heating unit is oversized. Exceptions: steam boilers and boilers with tankless coils. If the nozzle is oversized, replace the burner nozzle after selecting the correct nozzle size, spray angle, and spray pattern.
- ✓ Adjust the barometric damper for a negative overfire draft of -0.020 IWC or -5 pascals at a test plug in the heating unit.
- ✓ Adjust the air shutter to achieve the oxygen and smoke values, specified in [Table 8-6](#)
- ✓ Adjust oxygen, flue-gas temperature, CO, and smoke number to match manufacturer's specifications or specifications given here. Smoke number should be near zero on all modern oil-fired equipment.

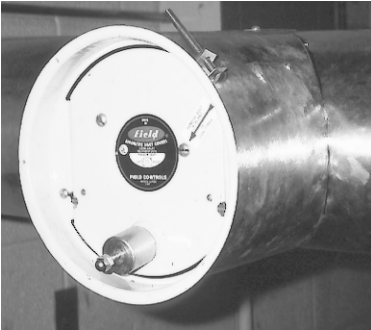

Barometric draft control: This control provides a stable overfire draft and controlled flow of combustion gases through the heat exchanger, when correctly adjusted.

Table 8-6: Minimum Oil Burner Combustion Standards

Oil Combustion Performance Indicator	Non Flame Retention	Flame Retention
Oxygen (% O ₂)	4–9%	4–7%
Stack temperature (°F)	350°–600°	325°–500°
Carbon monoxide (CO) parts per million (ppm as measured)	≤200 ppm	≤ 200 ppm
Steady-state efficiency (SSE) (%)	≥ 75%	≥ 80%
Smoke number (1–9)	≤ 2	≤ 1
Excess air (%)	≤ 100%	≤ 25%
Oil pressure pounds per square inch (psi)	≥ 100 psi	100–150 psi (pmi)*
Natural-draft venting: Overfire draft (negative)	–.020 IWC or –5 Pa.	> –.020 IWC or > –5 Pa.
Positive-pressure burner with natural-draft chimney and barometric control: Over-fire draft (positive)	n/a	0.020 to 0.120 IWC 5 to 30 Pa. or (pmi)*
Positive-pressure burner with horizontal vent and without a barometric control: Over-fire draft (positive)	n/a	0.20 to 0.60 IWC 50 to 150 Pa. or (pmi)*
* pmi = per manufacturer’s specifications		

Other Efficiency Testing and Adjustment

- ✓ Adjust the gap between electrodes and their angle for proper alignment.
- ✓ Measure the control-circuit amperage. Adjust the thermostat’s heat anticipator to match the amperage, or read the thermostat manufacturer’s instructions for adjusting cycle length.

- ✓ Measure the oil-pump pressure, and adjust it to manufacturer's specifications if necessary.
- ✓ Measure the transformer voltage, and make sure it meets manufacturer's specifications.
- ✓ Adjust the airflow or the water flow to reduce high flue-gas temperature if possible, but don't reduce flue-gas temperature below 350°F.

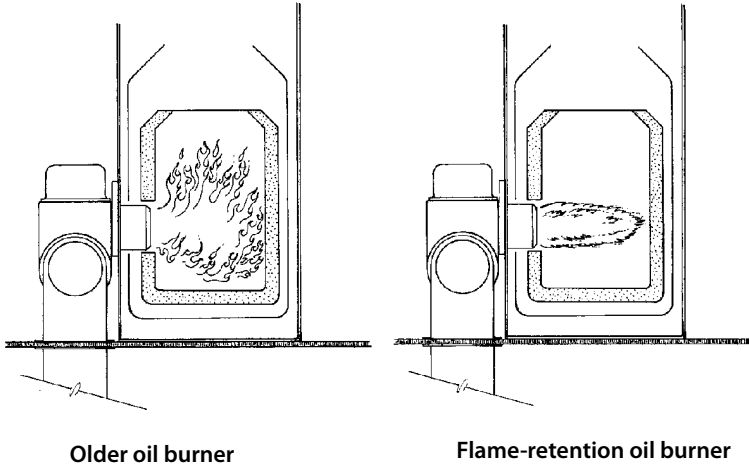

Flame-retention burner: The flame of a flame-retention burner is hotter and more compact than the older burner.

8.7.2 Oil Burner Inspection and Maintenance

SWS Detail: 5.0504.2 Oil Piping

Use visual inspection and combustion testing to evaluate oil burner operation. An oil burner that passes visual inspection and complies with the specifications may need no maintenance. Persistent unsatisfactory test results may indicate the need to replace the burner or the entire oil-fired heating unit.

Safety Inspection, Testing, and Adjustment

- ✓ Inspect burner and appliance for signs of soot, overheating, fire hazards, corrosion, or wiring problems.
- ✓ Inspect heat exchanger and combustion chamber for cracks, corrosion, or soot buildup.
- ✓ If the unit smells excessively of oil, test for oil leaks and repair the leaks.
- ✓ Time the flame sensor control or stack control to verify that the burner shuts off, within either 45 seconds or a time specified by the manufacturer, when the cad cell is blocked from seeing the flame.
- ✓ Measure the high limit shut-off temperature and adjust or replace the high limit control if the shut-off temperature is more than 200° F for furnaces, or 220° F for hot-water boilers.

Oil Burner Maintenance

After evaluating the oil burner's operation, specify some or all of these maintenance tasks as necessary, to optimize safety and efficiency.

- ✓ Clean the burner's blower wheel.
- ✓ Clean dust, dirt, and grease from the burner assembly.
- ✓ Replace oil filter(s) and nozzle.
- ✓ Clean or replace air filter.
- ✓ Remove soot from combustion chamber.
- ✓ Remove soot from heat exchange surfaces.
- ✓ Adjust gap between electrodes to manufacturer's specs.
- ✓ Check if the nozzle and the fire ring of the flame-retention burner is appropriate for the size of the combustion chamber.

- ✓ Repair the ceramic combustion chamber, or replace it if necessary.
- ✓ Verify correct flame sensor operation.

After these maintenance procedures, the technician carries out the diagnostic tests described previously to evaluate improvement made by the maintenance procedures and to determine whether more adjustment or maintenance is required.

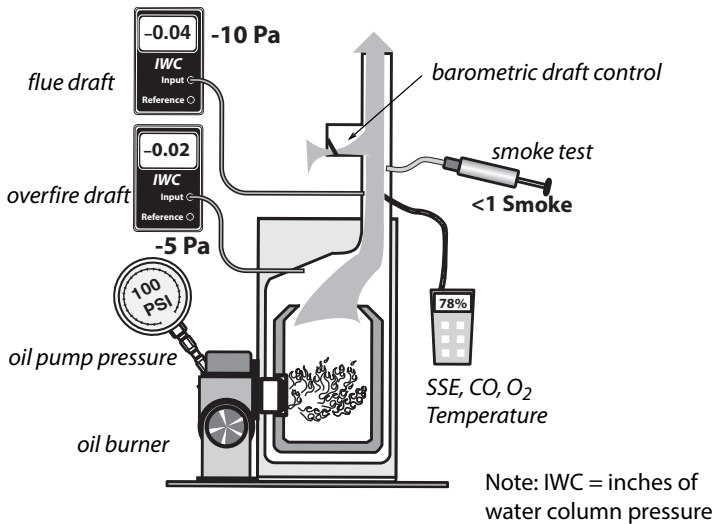

Measuring oil-burner performance: Measuring oil-burning performance requires a manometer, flue-gas analyzer, smoke tester, and pressure gauge.

8.8 INSPECTING FURNACE HEAT EXCHANGERS

All furnace heat exchangers should be inspected as part of weatherization.

Cracks or holes in heat exchangers are a common problem, causing the flue gases to mix with a building's air. Ask occupants about respiratory problems, flu-like symptoms, and smells in the building when the heat is on. Also, check around supply regis-

ters for signs of soot, especially with oil heating. Consider using one or more of these five options for evaluating heat exchangers.

1. Look for rust at exhaust ports and vent connectors.
2. Look for flame impingement on the heat exchanger during firing and flame damaged areas near the burner flame.
3. Observe flame movement when blower activates and deactivates.
4. Measure the flue-gas oxygen concentration before the blower starts and then again just after the blower starts. A change in oxygen level warrants further inspection. Oxygen levels for all types of furnaces should be steady once the appliance has reached Steady State.
5. Examine the heat exchanger visually. Use of lights and mirrors can be helpful.

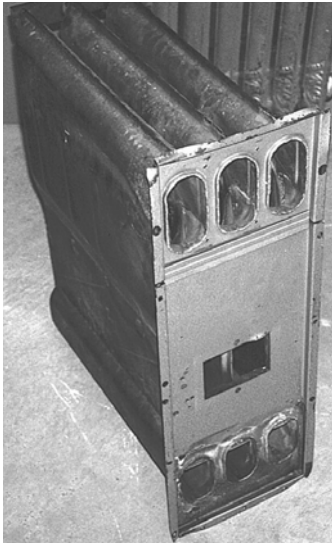

Furnace heat exchangers: Although no heat exchanger is completely airtight, it should not leak enough to display the warning signs described here.

8.9 WOOD STOVES

Step 1: Wood stoves and fireplaces can cause indoor air pollution and fire hazards. Inspect wood stoves to evaluate potential hazards. Solid fuel appliances are to be inspected for venting, depressurization, and installation issues. Use the Indiana Wood Stove form to document information. *See “DOE and IHCDA Health and Safety Plan.”*

8.9.1 Wood-Stove Clearances

Stoves that are listed by a testing agency like Underwriters Laboratory have installation instructions stating their clearance from combustibles. Unlisted stoves must adhere to clearances specified in NFPA 211.

Look for metal tags on the wood stove that list minimum clearances. Listed wood stoves may be installed to as little as 6 inches away from combustibles, if they incorporate heat shields and combustion design that directs heat away from the stove’s rear and side panels.

Unlisted stoves must be at least 36 inches away from combustibles. Ventilated or insulated wall protectors may decrease unlisted clearance from one-third to two thirds,. Refer to NFPA 211 for specific guidance. Always follow the stove manufacturer's or heat-shield manufacturer's installation instructions.

Floor Construction and Clearances

The floor of a listed wood stove must comply with the specifications on the listing (metal tag. Modern listed stoves usually sit on a 1-inch thick non-combustible floor protector that extends 18 inches beyond the stove in front.

The floor requirements for underneath an unlisted wood stove depends on the clearance between the stove and the floor, which depends on the length of its legs. Unlisted wood stoves must have floor protection underneath them unless they rest on a non-combustible floor. An example of a noncombustible floor is one composed of only masonry material.

An approved floor protector is either one or two courses of hollow masonry material (4 inches thick with a non-combustible quarter-inch surface of steel or other non-combustible material on top of the masonry. This floor for a non-listed wood stove must extend no less than 18 inches beyond the stove in all directions.

Vent-Connector and Chimney Clearance

Interior masonry chimneys require a 2-inch clearance from combustibles and exterior masonry chimneys require a 1-inch clearance from combustibles. All-fuel metal chimneys (insulated double-wall or triple wall usually require a 2-inch clearance from combustibles.

Double-wall stove-pipe vent connectors require a 9-inch clearance from combustibles or a clearance listed on the product. Single wall vent connectors must be at least 18 inches from combustibles. Wall protectors may reduce this clearance up to two-thirds.

8.9.2 Wood Stove Inspection

All components of wood stove venting systems should be approved for use with wood stoves. Chimney sections penetrating floor, ceiling, or roof should have approved thimbles, support packages, and ventilated shields to protect nearby combustible materials from high temperatures.

Perform or specify the following inspection tasks.

- ✓ Inspect stove, vent connector, and chimney for correct clearances from combustible materials as listed on stoves and vent assemblies or as specified in NFPA 211.
- ✓ Each wood stove must have its own dedicated flue pipe. Two wood stoves may not share a single flue.
- ✓ Perform CAZ depressurization for the space containing the wood stove. Negative 4 pascals is the maximum allowable depressurization for Indiana weatherization non-direct vent wood stove.
- ✓ Inspect vent connector and chimney for leaks. Leaks should be sealed with a high temperature sealant designed for sealing wood stove vents.
- ✓ Galvanized-steel pipe must not be used to vent wood stoves.
- ✓ Inspect chimney and vent connector for creosote build-up, and suggest chimney cleaning if creosote deposits exist.
- ✓ Inspect the house for soot on seldom-cleaned horizontal surfaces. If soot is present, inspect the wood stove door gasket. Seal stove air leaks or chimney air leaks with stove cement. Improve draft by extending the chimney to reduce indoor smoke emissions.
- ✓ Inspect stack damper and/or combustion air intake damper.

- ✓ Check catalytic converter for repair or replacement if the wood stove has one.
- ✓ Assure that heat exchange surfaces and flue passages within the wood stove are free of accumulations of soot or debris.
- ✓ Wood stoves installed in manufactured homes must be approved for use in manufactured homes.
- ✓ Consider having a qualified chimney inspection professional perform the evaluation on the wood stove.

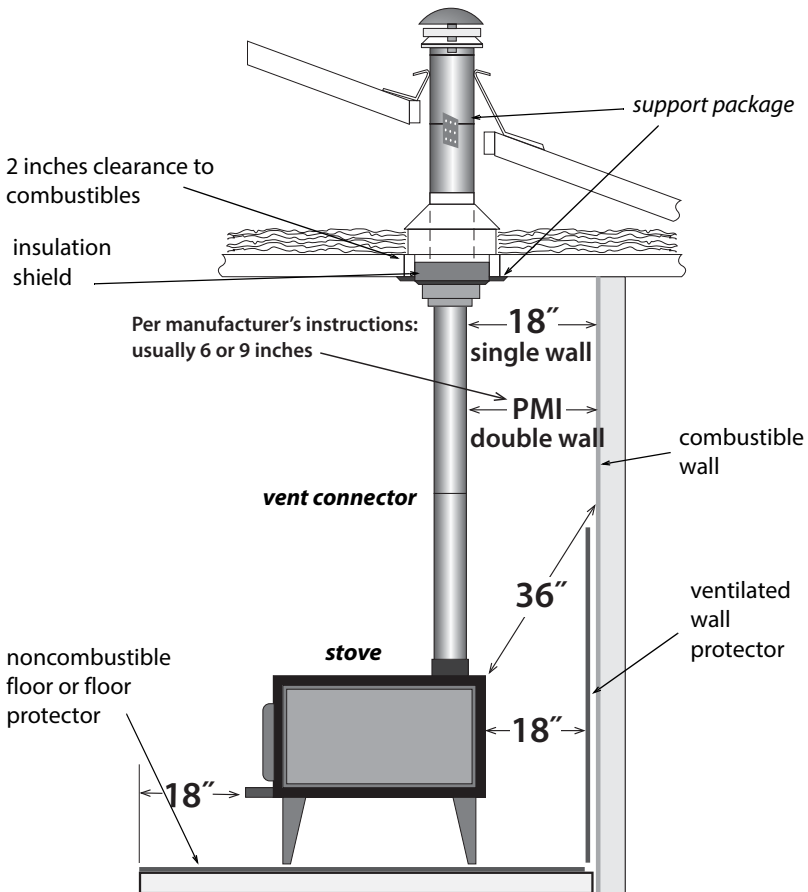

Wood-stove installation: Wood-stove venting and clearances are vitally important for wood-burning safety. Read manufacturer's instructions for the stove and its venting components.

8.10 INSPECTING VENTING SYSTEMS

SWS Detail: 5.0503.1 Fuel Fired Appliance Venting

Combustion gases are vented through vertical chimneys or other types of approved horizontal or vertical vent piping. Identifying the type of existing venting material, verifying the correct size of vent piping, and making sure the venting conforms

to the applicable codes are important tasks in inspecting and repairing venting systems. Too large a vent often leads to condensation and corrosion. Too small a vent can result in spillage. The wrong vent materials can corrode or deteriorate from heat.

NFPA Codes

The National Fire Protection Association (NFPA) publishes authoritative information on material-choice, sizing, and clearances for chimneys and vent connectors, as well as for combustion air. The information in this venting section is based on the following NFPA documents.

- NFPA 54: *The National Fuel Gas Code*
- NFPA 31: *Standard for the Installation of Oil-Burning Equipment*
- NFPA 211: *Standard for Chimneys, Fireplaces, Vents, and Solid-Fuel-Burning Appliances*

8.10.1 Vent Connectors

A vent connector connects the appliance to the vent or to the chimney. Approved vent connectors for gas-fired units are made from the following materials.

- Type-B vent, consisting of a galvanized steel outer pipe and aluminum inner pipe for gas-fired units.
- 26 gauge galvanized steel pipe.

Table 8-7: Single-Wall Galvanized Vent Connector Thickness

Diameter of Vent Connector (inches)	Inches (gauge)
5 and smaller	0.022 (26 gauge)
6 to 10	0.028 (24 gauge)
11 to 16	0.034 (22 gauge)
Larger than 16	0.064 (16 gauge)

From *International Mechanical Code 2009*

Double-wall vent connectors are the best option, especially for appliances with horizontally sloped. A double-wall vent connector can help maintain a sufficient flue gas temperature and prevents condensation.

Anywhere that draft is weak or flue gas temperature is low, use a double-wall vent connector. Gas appliances with draft hoods installed in unconditioned attics or crawl spaces must use a Type-B vent connector.

Use Type-L double-wall vent pipe for oil vent connectors in attics and crawl spaces.

Vent-Connector Requirements

Verify that vent connectors comply with these specifications.

- Vent connectors must be as large as the vent collar on the appliances they vent.
- Single wall vent-pipe sections must be fastened together with 3 screws or rivets at each joint.
- Vent connectors must be sealed tightly where they enter masonry chimneys.
- Vent connectors must be free of rust, corrosion, and holes.
- Maintain minimum clearances between vent connectors and combustibles.

Table 8-8: Clearances to Combustibles for Vent Connectors

Vent Connector Type	Clearance
Single wall galvanized steel vent pipe	6" (gas), 18" (oil)
Type-B double wall vent pipe (gas)	1" (gas)
Type L double wall vent pipe	3" or as listed (oil)
Single-wall stove pipe	18" (wood)
Double-wall stove pipe	9" or as listed (wood)

- The chimney combining two draft-hood vent connectors must have a cross-sectional area equal to the area of the larger vent connector plus half the area of the smaller vent connector. This common vent must be no larger than 7 times the area of the smallest vent connector. For specific vent sizes, see the NFPA codes.

Table 8-9: Areas of Round Vents

Vent diameter	4"	5"	6"	7"	8"
Vent area (square inches)	12.6	19.6	28.3	38.5	50.2

- The horizontal length of vent connectors shouldn't be more than 75% of the chimney's vertical height or have more than 18 inches horizontal run per inch of vent diameter.
- Vent connectors must have upward slope to their connection with the chimney. NFPA 54 requires a slope of at least 1/4-inch of rise per foot of horizontal run so that combustion gases rise through the vent. The slope also prevents condensation from collecting in the vent and corroding it.

Table 8-10: Connector Diameter vs. Maximum Horizontal Length

Diam (in)	3"	4"	5"	6"	7"	8"	9"	10"	12"	14"
Length (ft)	4.5'	6'	7.5'	9'	10.5'	12'	13.5'	15'	18'	21'

From International Fuel Gas Code 2000

- When two vent connectors connect to a single chimney, the vent connector servicing the smaller appliance must enter the chimney above the vent for the larger appliance.

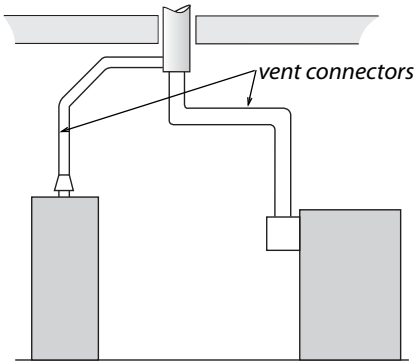

Two vent connectors joining chimney: The water heater's vent connector enters the chimney above the furnace or boiler because the water heater has a smaller input.

8.11 CHIMNEYS

There are two common types of vertical chimneys for venting combustion fuels that satisfy NFPA and ICC codes.

1. Masonry chimneys lined with fire-clay tile.
2. Manufactured metal chimneys, including all-fuel metal chimneys, Type-B vent chimneys for gas appliances, and Type L chimneys for oil appliances.

8.11.1 Masonry Chimneys

Verify the following general specifications for building, inspecting, and repairing masonry chimneys.

- A masonry foundation should support every masonry chimney.
- Existing masonry chimneys should be lined with a fire clay flue liner. There should be a $\frac{1}{2}$ -inch to 1-inch air gap between the clay liner and the chimney's masonry to insu-

late the liner. The liner shouldn't bond structurally to the outer masonry because the liner needs to expand and contract independently of the chimney's masonry structure. The clay liner seal to the chimney cap with a flexible high-temperature sealant.

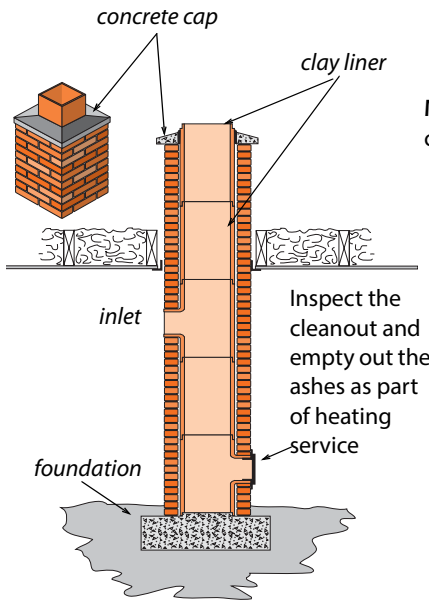

Masonry chimneys: Remain a very common vent for all fuels.

- Masonry chimneys should have a cleanout 12 inches or more below the lowest inlet. Clean mortar and brick dust out of the bottom of the chimney through the clean-out door, so that this debris won't eventually interfere with venting.
- Seal the chimney's penetrations through floors and ceilings with sheet metal and non-combustible sealant as a fire-stop and air barrier.
- Re-build deteriorated or unlined masonry chimneys as specified here or reline them as part of a heating-system replacement or a venting-safety upgrade. Or, install a new metal chimney instead of repairing the existing masonry chimney.

Metal Liners for Masonry Chimneys

Install or replace liners in unlined masonry chimneys or chimneys with deteriorated liners as part of heating system replacement. Water heaters may need a chimney liner because the existing chimney may be too large. Use a correctly sized Type-B vent, a flexible or rigid stainless-steel liner, or a flexible aluminum liner.

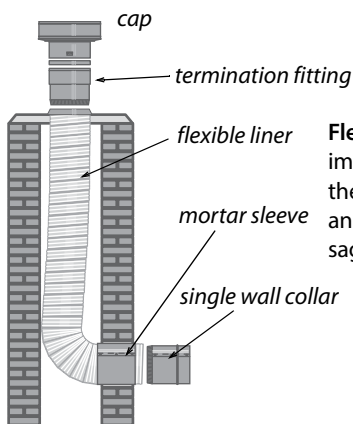

Flexible metal chimney liners: The most important installation issues are sizing the liner correctly along with fastening and supporting the ends to prevent sagging.

Flexible liners require careful installation to avoid a low spot at the bottom, where the liner turns a right angle to pass through the wall of the chimney. Comply with the manufacturer's instructions, which usually require stretching the liner and fastening it securely at both ends, to prevent the liner from sagging and creating a low spot.

Flexible liners are easily damaged by falling masonry debris inside a deteriorating chimney. Use B-vent, L-vent, or single-wall stainless steel pipe instead of a flexible liner when the chimney is significantly deteriorated.

To minimize condensation, insulate the flexible liner — especially when installed in exterior chimneys. Consider fiberglass-insulation jackets if the manufacturer's instructions require this. Wood-stove chimney liners must be stainless steel and insulated.

Sizing flexible chimney liners correctly is very important. Oversizing is common and can lead to condensation and corrosion. The manufacturers of the liners include vent-sizing tables in their specifications. Liners should display a label from a testing lab like Underwriters Laboratories (UL).

Masonry chimneys as structural hazards: A building owner may want to consider reinforcing a deteriorated chimney by re-pointing masonry joints or parging the surface with reinforced plaster. Other options include demolishing the chimney or filling it with concrete to prevent it from damaging the building by collapsing during an earthquake.

Solutions for Failed Chimneys

Sometimes a chimney is too deteriorated to be re-lined or repaired. In this case, abandon the old chimney, and install one of the following.

- A double-wall horizontal sidewall vent, equipped with a barometric draft control and a power venter mounted on the exterior wall. Maintain a 4-foot clearance between the ground and the vent's termination if you live where it snows.
- A new heating unit, equipped with a power burner or draft inducer, that is designed for horizontal or vertical venting.
- A new manufactured metal venting system.
- A new sealed-combustion heating unit, equipped with a combustion-air source from outdoors.

Table 8-11: Clearances to Combustibles for Common Chimneys

Chimney Type	Clearance
Interior chimney masonry w/ fire clay liner	2"
Exterior masonry chimney w/ fire clay liner	1"
All-fuel metal vent: insulated double-wall or triple-wall pipe	2"
Type B double-wall vent (gas only)	1"
Type L double-wall vent (oil)	3"
Manufactured chimneys and vents list their clearances.	

8.11.2 Manufactured Chimneys

Manufactured metal chimneys have engineered parts that fit together in a prescribed way. Parts include: metal pipe, weight-supporting hardware, insulation shields, roof jacks, and chimney caps. One manufacturer's chimney may not be compatible with another's connecting fittings.

All-fuel chimneys (also called Class A chimneys) are used primarily for the solid fuels: wood and coal. All-fuel metal chimneys come in two types: insulated double-wall metal pipe and triple-wall metal pipe. Comply with the manufacturer's specifications when you install these chimneys.



All-fuel metal chimney: These chimney systems include transition fittings, support brackets, roof jacks, and chimney caps. The pipe is double-wall insulated or triple-wall construction.



Type-B vent double-wall pipe is permitted as a chimney for gas appliances. Type BW pipe is manufactured for gas space heaters in an oval shape to fit inside wall cavities.

Type L double-wall pipe is used for oil chimneys.

8.11.3 Chimney Terminations

Masonry chimneys and all-fuel metal chimneys should terminate at least three feet above the roof penetration and two feet above any obstacle within ten feet of the chimney outlet.

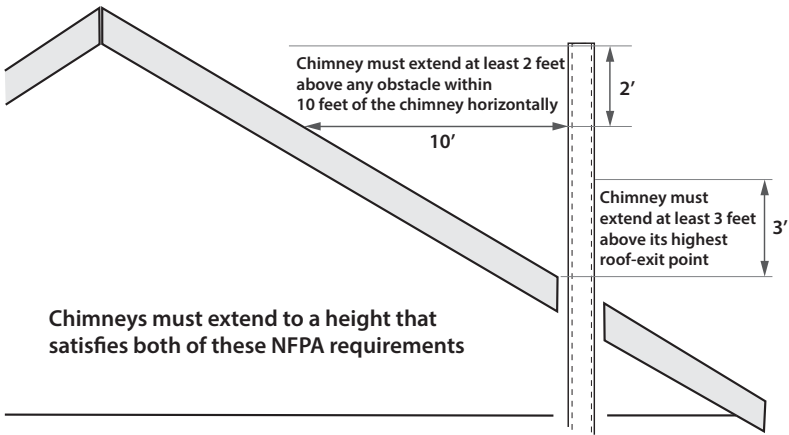

Chimney terminations: Should have vent caps and be given adequate clearance height from nearby building parts. These requirements are for both masonry chimneys and manufactured all-fuel chimneys.

Type B vents can terminate as close as one foot above flat roofs and above pitched roofs up to a $\frac{6}{12}$ roof pitch. As the pitch rises, the minimum required termination height as measured from the high part of the roof slope, rises as shown in this table.

Table 8-12: Roof Slope and B-Vent Chimney Height (ft)

flat-	6/12-	7/12-	8/12-	9/12-	10/12-	11/12-	12/12-	14/12-	16/12-
6/12	7/12	8/12	9/12	10/12	11/12	12/12	14/12	16/12	18/12
1'	1' 3"	1' 6"	2'	2' 6"	3' 3"	4'	5'	6'	7'

From *National Fuel Gas Code 2009*

8.11.4 Decommissioning Chimneys

Exterior:

- Cover chimney top with a chimney cap with an animal screen/guard
- Top of chimney should NOT be permanently disabled/airsealed
- Safety of weatherization professionals is paramount
- If a chimney cap is not a feasible option, sub-grantee must submit meaningful photograph(s) and request waiver to IWX@ihcda.in.gov

Interior:

- Install foam board and drywall with a support structure to ensure durability
- The decommissioned fireplace must be tagged as “Unsafe to Use”
- When a solid fuel open hearth fireplace is present, the blower door must be operated at 300 cfm to simulate a fire in the fireplace. If open hearth fireplace is left operating post weatherization, it must be inspected by a qualified chimney sweep and must be deemed safe to use. A copy of this letter must be placed in the client file.
- The Worst Case CAZ Depressurization limit for a wood stove which obtains combustion air from the home is -4.0 Pascals.
- The Worst Case CAZ Depressurization limit for an EPA approved direct vent wood stove is -10.0 Pascals.
- If either of these limits are met or exceeded, the respective wood stove will require decommissioning. A copy of the Worst Case Testing form for all of the abovementioned systems must be in the client file.

8.12 SPECIAL VENTING CONSIDERATIONS FOR GAS

- The American Gas Association (AGA) publishes a classification system for venting systems attached to natural-gas and propane appliances. This classification system assigns Roman numerals to four categories of venting based on whether there is positive or negative pressure in the vent and whether condensation is likely in the vent.

AGA venting categories:
The AGA classifies venting by whether there is positive or negative pressure in the vent and whether condensation is likely.

	Negative-pressure Venting	Positive-pressure
Non-condensing	<p>I</p> <p>Combustion Efficiency 83% or less</p> <p>Use standard venting: masonry or Type B vent</p>	<p>III</p> <p>Combustion Efficiency 83% or less</p> <p>Use only pressurizable vent as specified by manufacturer</p>
Condensing	<p>II</p> <p>Combustion Efficiency over 83%</p> <p>Use only special condensing-service vent as specified by manufacturer</p>	<p>IV</p> <p>Combustion Efficiency over 83%</p> <p>Use only pressurizable condensing-service vent as specified by manufacturer</p>
American Gas Association Vent Categories		

A majority of gas appliances found in homes and multifamily buildings are Category I. They have negative pressure in their vertical chimneys. We expect no condensation in the vent connector or chimney in a Category I appliance.

Condensing furnaces are usually Category IV, have positive pressure in their vent, and condensation occurring in both the appliance and vent.

Category III vents are rare, however a few fan-assisted furnaces and boilers vent their flue gases through airtight non-condensing vents. Category II vents are very rare and beyond the scope of this discussion.

8.12.1 Venting Fan-Assisted Furnaces and Boilers

Newer gas-fired fan-assisted central furnaces and boilers eliminate dilution air and may have slightly cooler flue gases compared to their predecessors. The chimney may experience more condensation than in the past. Inspect the existing chimney to verify that it's in good condition when considering replacing an

old natural-draft unit. Reline the chimney when you see any of these conditions.

- When the existing masonry chimney is unlined.
- When the old clay or metal chimney liner is deteriorated.
- When the chimney is too large for the smallest Btuh appliance. Refer to NFPA 54 vent sizing guidance.
- When an 80% mid-efficiency furnace is vented into a masonry chimney by itself, regardless of the condition of the chimney.

B-vent chimney liner: Double wall Type-B vent is the most commonly available chimney liner and is recommended over flexible liners. Rigid stainless-steel single wall liners are also a permanent solution to deteriorated chimneys.

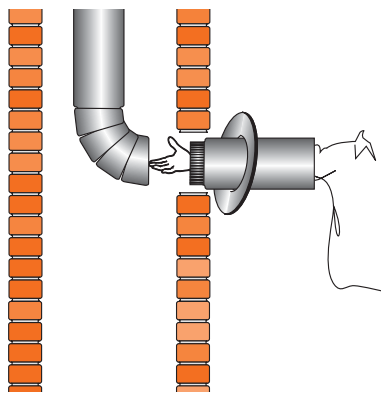

Liner Materials for 80+ Furnaces

For gas-fired 80+ AFUE furnaces, a chimney liner should consist of one of these four materials.

1. A type-B vent
2. A rigid or flexible stainless steel liner (preferably insulated)
3. A poured masonry liner
4. An insulated flexible aluminum liner

Chimney relining is expensive. Therefore consider a power-vented sealed-combustion unit when an existing chimney is inadequate for a new fan-assisted appliance.

8.12.2 Venting Sealed-Combustion Furnaces and Boilers

Some space heaters, furnaces, and boilers use seamless, stainless steel vents for Category III venting (e.g. - AL29-4C) that vent horizontally under positive pressure.

Condensing furnaces usually employ horizontal or vertical plastic-pipe chimneys.

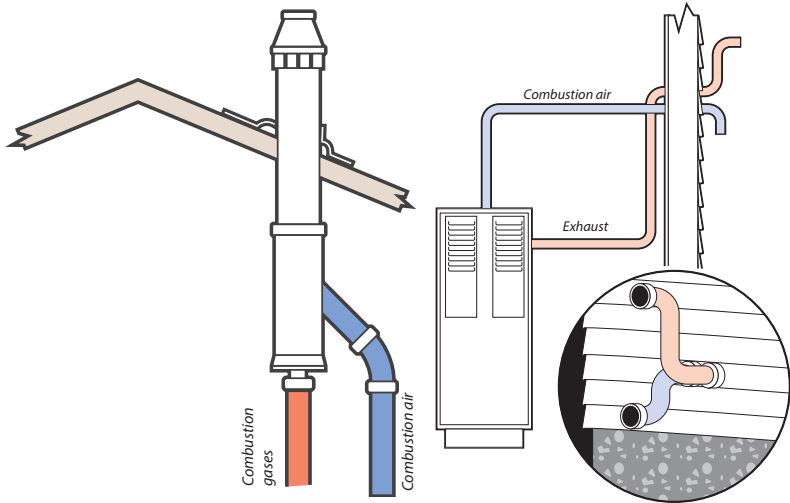

Two types of sealed-combustion vents: On the left is a concentric vent exiting through a roof. On the right is a plastic-pipe vent and combustion-air opens through the wall.

8.12.3 Sidewall Power Venting

Stainless-steel vents powered by fans in gas and oil appliances exit through walls and don't require vertical chimneys.

Table 8-13: Characteristics of Gas Furnaces and Boilers

Annual Fuel Utilization Efficiency (AFUE)	Operating characteristics
70+	Category I, draft diverter, no draft fan, standing pilot, non-condensing, indoor combustion and dilution air.
80+	Category I, no draft diverter, fan-assisted draft, electronic ignition, indoor combustion air, no dilution air.
80+	Category III, horizontal fan-pressurized non-condensing airtight vent, indoor combustion air, no dilution air.
90+	Category IV, no draft diverter, fan-assisted draft, low-temperature plastic venting, positive draft, electronic ignition, condensing heat exchanger, outdoor combustion air is strongly recommended.

8.13 DUCTED AIR DISTRIBUTION

SWS Detail: 5.0104 Duct Installation; 5.0104.1 New Duct Components; 5.0105 Duct Repair; 5.0106 Duct Sealing

The forced-air system consists of an air handler (furnace, heat pump, air conditioner with its heat exchanger along with attached ducts. The annual system efficiency of forced-air heating and air-conditioning systems depends on the following issues.

- Duct leakage
- System airflow
- Blower operation
- Balance between supply and return air

- Duct insulation levels



Video: Duct energy efficiency— An overview of the elements that make up and affect the energy efficiency of duct systems.

8.13.1 Sequence of Operations

The evaluation and improvement of ducts has a logical sequence of steps.

1. Solve the airflow problems. Contractors may need to add or modify the duct system.
2. Determine whether the ducts are located inside the thermal boundary or outside it.
3. Evaluate the ducts' air leakage and decide whether duct-sealing is necessary and if so, find and seal the duct leaks.
4. If ducts are outside the thermal boundary or if condensation is a problem, insulate the ducts.

8.13.2 Solving Airflow Problems

You don't need test instruments to discover dirty blowers or disconnected branch ducts. Find these problems before measuring duct airflow, troubleshooting the ducts, or sealing the ducts. These steps precede airflow measurements.

1. Ask the client about comfort problems and temperature differences in different rooms of the home.

2. Based on the clients comments, look for disconnected ducts, restricted ducts, and other obvious problems.
3. Inspect the filter(s), blower, and indoor coil for dirt. Clean them if necessary. If the indoor coil isn't easily visible, a dirty blower means that the coil is probably also dirty.
4. Inspect for dirty or damaged supply and return grilles that restrict airflow. Clean and repair them.
5. Inspect for closed registers or closed balancing dampers that could be restricting airflow to uncomfortable rooms.
6. Inspect for kinked, or un-stretched flex duct and repair the flex duct as necessary.
7. Inspect for moisture problems like mold and mildew man.

Measuring Total External Static Pressure (TESP)

The blower creates the duct pressure that you can measure in inches of water column (IWC or pascals. The return static pressure is negative and the supply static pressure is positive. Total external static pressure (TESP is the sum of the absolute values of the supply and return static pressures. Absolute value means that you ignore the positive or negative signs when adding supply static pressure and return static pressure to get TESP. This addition represents the distance on a number line as shown in the illustration here.

TESP number line: the TESP represents the distance on a number line between the return and supply ducts.

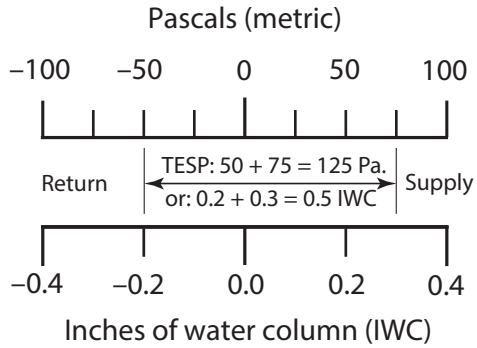

TESP gives a rough indicator of whether airflow is adequate or not. The greater the TESP, the less the airflow. The supply and return static pressures by themselves can indicate whether the supply or the return or both sides are restricted. For example, if the supply static pressure is 0.10 IWC (25 pascals) and the return static pressure is -0.5 IWC (-125 pascals), you can assume that most of the airflow problems are due to a restricted or undersized return.

The TESP gives a rough estimate of airflow if the manufacturer's graph or table for static pressure versus airflow is available.

1. Attach two static pressure probes to tubes leading to the two ports of the manometer. Attach the high-side port to the probe inserted downstream of the air handler in the supply duct. The other tube goes upstream of the air handler in the return duct. The manometer adds the supply and return static pressures to measure TESP.
2. Consult manufacturer's literature for a table of TESP versus airflow for the blower or the air handler. Find airflow for the TESP measured in Step 1.
3. Measure pressure on each side of the air handler to obtain both supply and return static pressures separately. This test helps to locate the main problems as related to either the supply or the return.

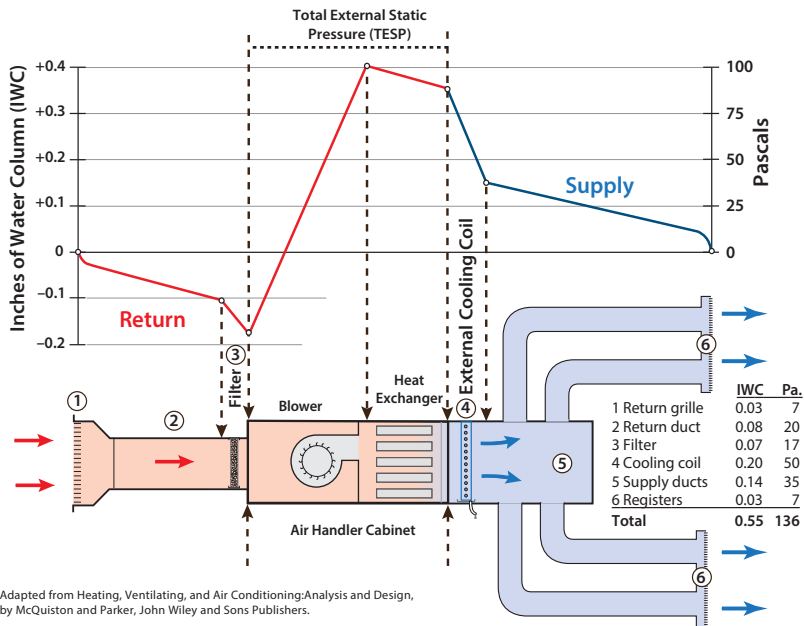

Adapted from Heating, Ventilating, and Air Conditioning: Analysis and Design, by McQuiston and Parker, John Wiley and Sons Publishers.

Visualizing TESP: The blower creates a suction at its inlet and a positive pressure at its outlet. As the distance between the measurement and blower increase, pressure decreases because of the system's lower resistance.

Static Pressure Guidelines

Air handlers deliver their airflow at TESP's ranging from 0.30 IWC (75 Pascals to 1.0 IWC (250 Pascals as found in the small buildings. Manufacturers maximum recommended static pressure is usually 0.50 IWC (125 pascals for standard air handlers. TESP's greater than 0.50 IWC indicate inadequate airflow in standard residential forced-air systems.

The popularity of pleated filters, electrostatic filters, and high-static high-efficiency evaporator coils, prompted manufacturers to introduce premium air handlers that can deliver adequate airflow at a TESP of greater than 0.50 IWC (125 pascals.

Premium residential air handlers can provide adequate airflow with TESP's of up to 0.90 IWC (225 pascals because of their more powerful blowers and variable-speed blowers. TESP's

greater than 0.90 IWC indicate the possibility of inadequate air-flow in these premium residential air handlers.

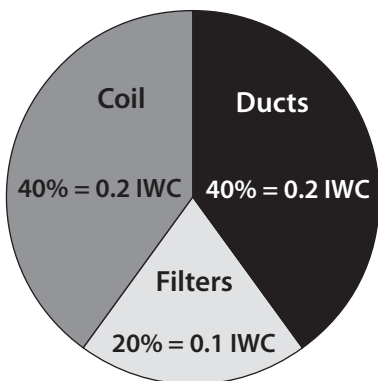

Static pressure budget: Typical static pressures in IWC with percentages for an effective duct system.

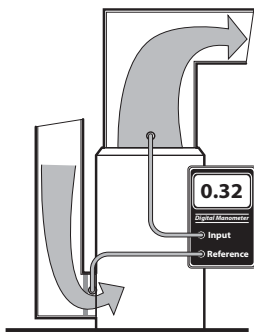

Total external static pressure (TESP): The positive and negative pressures created by the resistance of the supply and return ducts produces TESP. The measurement shown here adds the two static pressures without regard for their signs. As TESP increases, airflow decreases. Numbers shown below are for example only.

Table 8-14: Total External Static Pressure Versus System Airflow for a Particular System

TESP (IWC)	0.30	0.40	0.50	0.60	0.70	0.80
CFM	995	945	895	840	760	670

Example only

8.13.3 Unbalanced Supply-Return Airflow Test

Closing interior doors often separates supply registers from return registers in homes with central returns. A bedroom without a return register and with a closed door restricts the bedroom air from returning to the air handler. This restriction

pressurizes bedrooms and depressurizes the central areas near return registers. These pressures can drive air leakage through the building shell, create moisture problems, and bring pollutants in from the crawl space, garage, or CAZ.

The following tests use only the air handler and a digital manometer to evaluate whether the supply air can flow back to the return registers relatively unobstructed. Activate the air handler and close interior doors.

1. Measure the pressure difference between the home's central living area and the outdoors with a digital manometer.
2. Measure the bedrooms' pressure difference with reference to outdoors.
3. Or, you can measure the pressure difference between the central zone and the bedroom.

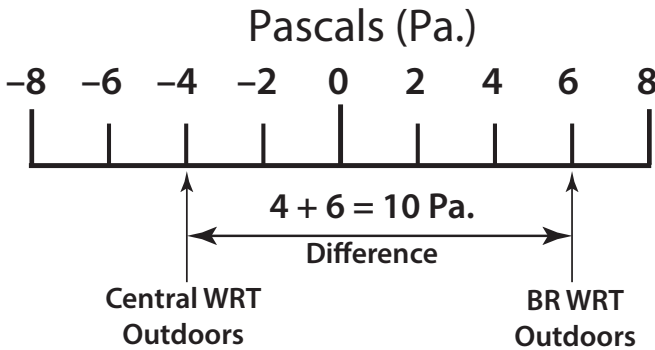

Measuring unbalanced airflow: The distance on a number line represents the difference in pressure between the central zone and the bedroom.

If the difference between the bedroom and central zone is more than 3.0 pascals with the air handler operating, pressure relief is desirable. Like TESP, disregard the positive or negative signs, and add the absolute values.

To estimate the amount of pressure relief needed, slowly open the bedroom door until the pressure difference drops below 3 pascal.

Estimate the surface area of that door opening. This is the area of the permanent opening required to provide pressure relief. Pressure relief may include undercutting the door, installing transfer grilles or installing jumper ducts. Another, more expensive, option would be to install a dedicated return duct directly to the problem room.

In manufactured housing, the desirable 3 pascals of pressure or less is sometimes not practical. Reasonable attempts should be made to pressure relieve to the desirable 3 pascals of pressure.

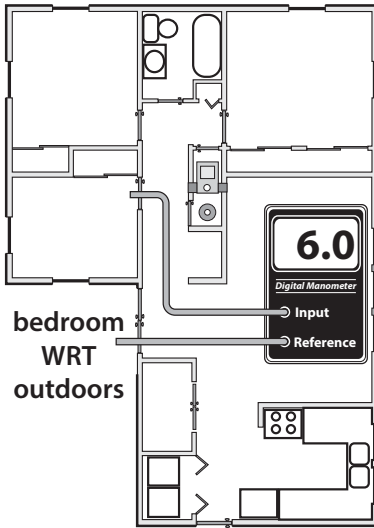

Pressurized bedrooms: Bedrooms with supply registers but no return register are pressurized when the air handler is on and the doors are closed. Pressures this high can double or triple air leakage through the building shell.

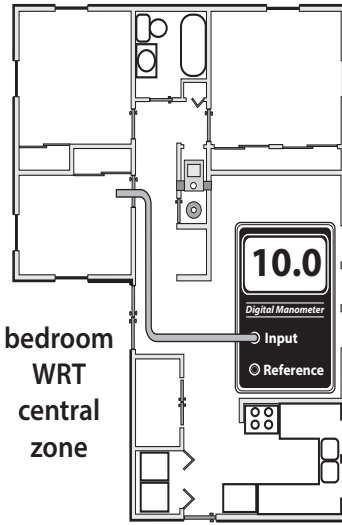

Pressure difference bedroom to central zone: The air handler depressurizes the central zone and pressurizes the bedroom, when the bedroom doors are closed. This test measures the pressure difference.

8.13.4 Evaluating Furnace Performance

The efficiency of a furnace depends on its temperature rise, fan-control temperatures, and combustion properties. For efficiency, you want a low temperature rise. However, the furnace must maintain a minimum flue-gas temperature to prevent corrosion in the venting of 70+ and 80+ AFUE units.

Apply the following furnace-operation standards to maximize the heating system's seasonal efficiency and safety.

- ✓ Perform a combustion analysis as described in *“Gas Burner Safety & Efficiency Service”*
- ✓ Check temperature rise after 5 minutes of operation. Refer to manufacturer’s nameplate for acceptable temperature rise (supply temperature minus return temperature). The temperature rise should be between the minimum and maximum temperature rise on the nameplate. Prefer the lower end of this range for energy efficiency.
- ✓ With temperature-activated controls, verify that the fan-on temperature is 120–140° F. The lower the better.
- ✓ With time-activated fan controls, verify that the fan is switched on with the shortest time delay available if it’s adjustable. The control should switch the fan off when the fan off temperature is 20° to 30° above the measured return-air temperature.
- ✓ Verify that the high-limit controller shuts the burner off before the furnace temperature reaches manufacturer’s maximum outlet temperature.
- ✓ Verify that there is adequate airflow from all supply registers.
- ✓ Adjust fan control to conform to the operating parameters on the diagram or replace the fan control if this adjustment fails. Some fan controls are not adjustable. This is more important in Category I furnaces than in Category IV furnaces as there is not much energy loss in the Category IV furnaces when installed inside the thermal boundary.
- ✓ Test and replace the high-limit control as necessary.
- ✓ All forced-air heating systems must deliver supply air and collect return air only from inside the conditioned rooms of the house. Taking return air from an unheated area of the house such as an unconditioned basement or a crawl space is not acceptable.

Table 8-14: Furnace Operating Parameters

Inadequate temperature rise: condensation and corrosion possible.	Temperature rise OK for both efficiency and avoidance of condensation.	Temperature is excessive: Check fan speed, heat exchanger and ducts.
---	--	--

20° 45° 70° 95°
Temperature Rise = Supply Temperature – Return Temperature

Excellent fan-off temperature if comfort is acceptable.	Acceptable: Consider extending fan delay off time.	Unacceptable range: Consider extending fan delay off time.
---	--	--

+20° +25° +30° °>30
Fan-off Temperature compared to return temperature

--	--	--

8.13.5 Package Units (Air Handlers)

*SWS Detail: 5.0108 Equipment Installation;
 5.0108.2 Air to Air Package Unit*

Package units are air handlers located on roofs or on slabs or platforms outdoors. Package unit may contain one or more of the following.

- A combustion furnace
- All the components of an air conditioner (packaged or unitary air conditioner)
- All the components of an heat pump (packaged or unitary heat pump)

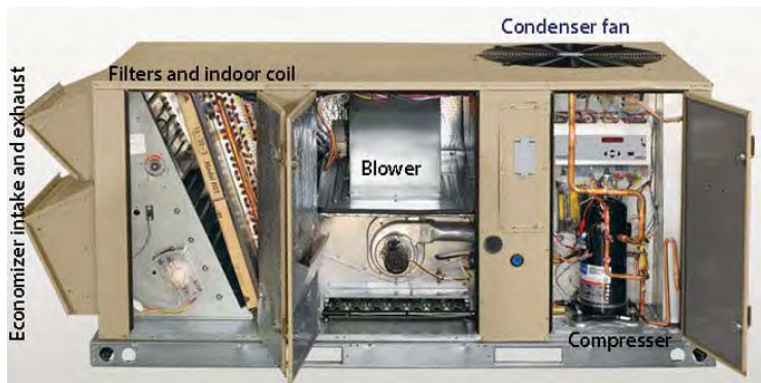

Package Unit: HVAC manufacturers and dealers classify as unitary or packaged central HVAC systems. They may contain all the components for heating, cooling, and ventilation.

- Outdoor-air damper with another damper, called an economizer for ventilation and free cooling.

Economizers

A controller in the economizer measures the temperature (and humidity in humid climates) of the outdoor air. When the outdoor conditions are favorable, the control switches the air conditioning compressor off and cools the building with outdoor air instead. The economizer uses far less cooling energy compared to air conditioning.

Economizers typically operate at night when the outdoor air is cooler than the indoor air in a process known as “free cooling”. Economizers mix enough outdoor air into the indoor air in order to meet the thermostat setpoint (which may be lower than the AC setpoint, without using the compressor).

Fresh air that economizers exchange with indoor air while they save cooling energy at night can also count as ventilation. Therefore the ventilation system can run for fewer hours and avoid operating during the day’s peak electrical load.

Package Unit Maintenance and Improvement

Because Package units are located outdoors, they are even more likely to be neglected compared to indoor air handlers. Fortunately though, the package unit components are more accessible compared to indoor air handlers.

Consider the following maintenance and improvements for package units.

- ✓ Clean or change filters, provide extra filters, and educate the building owner on filter maintenance.
- ✓ Test the combustion furnace as you would an indoor furnace. *See “Combustion-Safety Evaluation”*
- ✓ Clean the evaporator and condenser coils as specified.
- ✓ Test the unit and its ducts for air leakage because many RTUs systems have high duct leakage. *See “Air Filter Effectiveness”*
- ✓ Test and adjust the economizer to maximize its benefit for both free cooling and ventilation.
- ✓ Educate the building owner or operator on economizer function and control. Replace the thermostat, if necessary to accommodate optimal economizer functioning.

8.13.6 Recommended Airflow for Air Handlers

Troubleshooting Temperature Rise (combustion furnace)

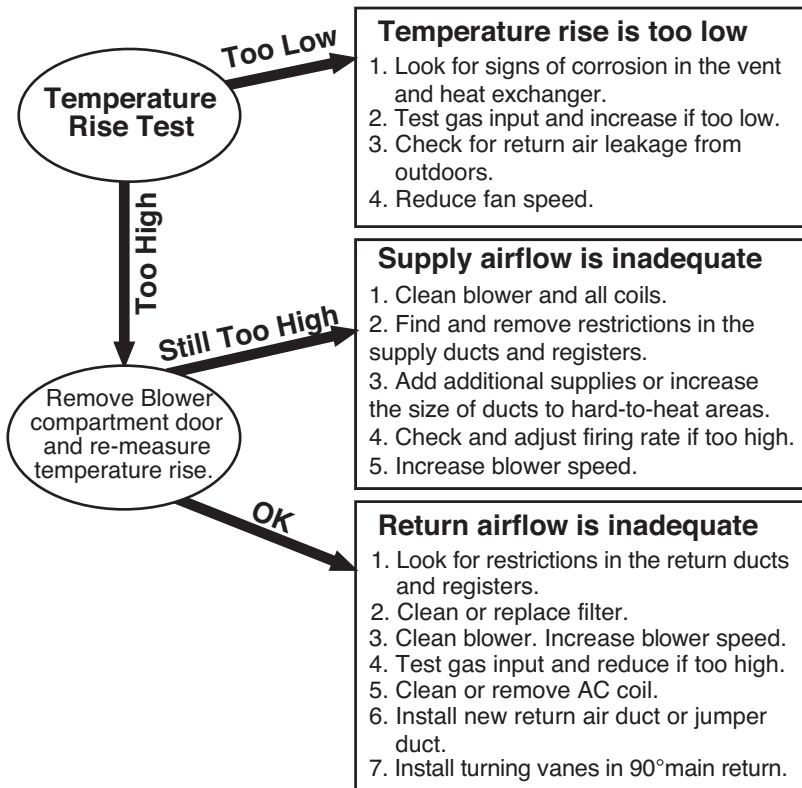

8.13.7 Improving Forced-Air System Airflow

Inadequate airflow is a common cause of comfort complaints. When the air handler is on there should be a strong airflow out of each supply register. Low register airflow may mean that a branch duct is blocked or separated, or that return air from the room to the air handler isn't sufficient.

When low airflow is a problem, consider specifying the following improvements as appropriate from your inspection.

- ✓ Clean or change filter. Select a less restrictive filter (lower MERV rating) if you need to reduce static pressure substantially.
- ✓ Clean air handler's blower.
- ✓ Clean the air-conditioning coil or heat pump coil. If the blower is dirty, the coil is probably also dirty.
- ✓ On a condensing furnace, clean the secondary heat exchanger coil.
- ✓ Increase blower speed.
- ✓ Make sure that balancing dampers to rooms that need more airflow are wide open.
- ✓ Lubricate the blower motor, and check tension on drive belt.

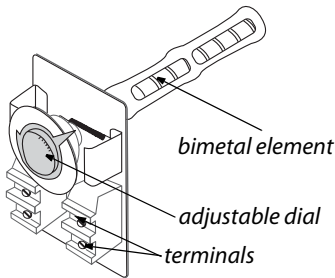

Fan/limit control: Turns the furnace blower on and off, according to temperature. Also turns the burner off if the heat exchanger overheats.

Duct Improvements to Increase Airflow

Consider specifying the following duct changes to increase system airflow and reduce the imbalance between supply airflow and return airflow.

- ✓ Modify the filter installation to allow easier filter changing, if filter changing is currently difficult.
- ✓ Remove obstructions to registers and ducts such as rugs, furniture, and objects placed inside ducts (children's toys and water pans for humidification, for example).

- ✓ Remove kinks from flex duct, and replace collapsed flex duct and deteriorating fiberglass duct board.
- ✓ Remove excessive lengths of slacking flex duct, and stretch the duct to enhance airflow.
- ✓ Perform a Manual D sizing procedure to evaluate whether to replace branch ducts that are too small.
- ✓ Install additional supply ducts, return ducts, and registers as needed to provide heated air throughout the building, especially in additions to the building.
- ✓ Pressure relieve rooms as needed
- ✓ Repair or replace bent, damaged, or restricted registers. Install low-resistance registers and grilles.

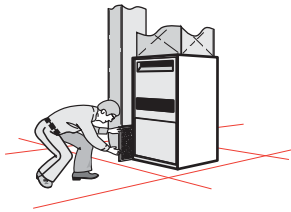

Panel filter installed in filter slot in return plenum

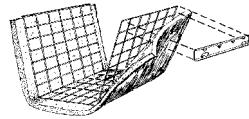

Washable filter installed on a rack inside the blower compartment.

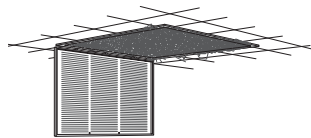

Panel filter installed in return register

Air-handler filter location: Filters are installed on the return-air side of forced air systems. Look for them in one or more of the above locations.

8.13.8 Air Filtration for Air Handlers

SWS Detail: 5.0104 Duct Installation; 5.0105 Duct Repair; 5.0106 Duct Sealing

Manufacturers equip air handlers with air filters at the factory or recommend that installers install air filters in return ductwork. The purpose of these filters is to protect the blower and heat exchangers from fouling by dust and particles.

Air Filter Effectiveness

The most common filter-rating method is the Minimum Efficiency Rating Value (MERV). A higher MERV rating means that the filter removes more particles and a larger fraction of smaller particles.

The MERV rating system divides particles into three size categories: 0.3–1, 1–3, and 3–10 microns. The two smallest categories are the most important for human health, as small respirable particles (PM 2.5) can more easily deposit in the lungs compared to larger particles.

The need for high MERV filters depends on the severity of the particle problem in a building. Particles less than 2.5 microns are the most dangerous because they can lodge themselves deep in the lungs. Filtering air with a long-running central air handler or a portable air cleaner can be energy intensive and it may or may not be effective.

The MERV ratings of available HVAC filters range from MERV 3 to MERV 16, with higher ratings removing more particles at smaller sizes. A MERV 3 filter captures large particles — clothing fibers, pollen, and dust mites, but few smaller respirable particles. A MERV16 filter captures more than 95% of all three particle sizes, including bacteria and tobacco smoke. The minimum MERV rating to remove 50% of the respirable 1–3 microns particle-size range is MERV 10.

Air Filter Pressure and Airflow Effects

Air filters affect the airflow and energy consumption of forced air HVAC systems and balanced ventilation systems. Before choosing the type of air filter, consider its MERV rating and a home's need for particle removal.

HVAC designers designed air handlers for use with low-MERV filters with a small pressure drop. Changing to higher-MERV filters can cause the filter pressure drop to increase and the system airflow to decrease.

Insufficient airflow may cause blowers to fail prematurely as they struggle to overcome system pressures beyond their design specification. For heating systems, the furnaces may overheat and cycle on their high limit switches. Airflow reductions in cooling systems risk coil icing and premature compressor failure.

To reduce the resistance of an high-MERV air filter, consider installing steps to accommodate a larger filter with more surface area and less static-pressure drop compared to the existing filter.

- A slanted filter bracket assembly
- An enlarged filter fitting to allow a filter with more surface area

8.14 EVALUATING DUCT AIR LEAKAGE

Duct leakage is a major energy loss source in buildings where the ducts reside outside the home's thermal boundary in a crawl space, attic, attached garage, or unconditioned basement. When these ducts remain outside the thermal boundary after weatherization, duct sealing is cost effective.

Duct leakage inside the thermal boundary isn't usually a severe energy or comfort problem unless the leaks are causing pressure imbalances in the dwelling or duct zone.

8.14.1 Troubleshooting Duct Leakage

Locate the duct leaks and evaluate their severity using one or more of the following procedures.

Finding duct air leaks: Finding the exact location of duct leaks precedes duct air sealing.

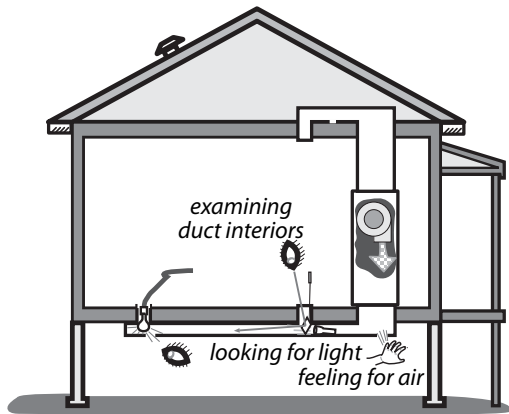

Pressure Pan Testing

Pressure pan tests can identify leaky or disconnected ducts located in intermediate zones. Pressure pan measurements are taken at supply and return registers while using the blower door to depressurize the house to -50 pascals. **Pressure pan testing is required when ducts are located outside the thermal boundary or when returns are part of the building structure such as panned floor joists or wall cavities.**

If the ducts are located within the thermal boundary, typically, pressure pan testing isn't really necessary if the following steps are taken.

- Returns are sealed in the CAZ, basements or crawlspaces for H&S reasons.

- Verify that the duct zone pressure does not change when the air handler is operated.

1. Install blower door and set-up house for winter conditions. Open all interior doors.

2. If the basement is conditioned living space, open the door between the basement and upstairs living spaces.

3. If the basement isn't conditioned living space, close the door between basement and upstairs. Then measure and record the zone pressure of the basement with reference to the conditioned space to confirm that the conditioned space and basement are separate spaces with a substantial pressure difference between them.

Close garages as much as possible to the outdoors so they don't create a secondary air barrier.

4. Turn furnace off at the thermostat or main switch. Remove furnace filter, and temporarily tape filter slot if one exists. Be sure that all grilles, registers, and damp-ers are fully open.

5. Temporarily seal any outside fresh-air intakes to the duct system.

6. Seal supply registers in unoccupied zones that aren't intended to be heated — an unconditioned basement or crawl space, for example.

7. Open attics, crawl spaces, and garages as much as possible to the outdoors so they don't create a secondary air barrier.

8. Connect hose between pressure pan and the input tap on the digital manometer. Leave the reference tap open.

9. With the blower door's manometer reading -50 pascals, place the pressure pan completely over each grille or register one by one to form a tight seal. Leave all other grilles and registers open when making a test. Record each reading, which should give a positive pressure.
10. If a grille is too large or a supply register is difficult to cover with the pressure pan (under a kitchen cabinet, for example), seal the grille or register with masking tape. Insert a pressure probe through the masking tape and record the reading. Remove the tape after the test.
11. Use either the pressure pan or tape to test each register and grille in a systematic way.

Pressure Pan Duct Standards

If the ducts are perfectly sealed with no leakage to the outdoors, you won't measure any pressure difference (0.0 pascals during a pressure-pan test. The higher the measured pressure reading, the more connected the duct is to the outdoors.

- For H&S reasons, seal all returns located in the CAZ, basement or crawlspace.
- Seal any ducts located inside the thermal boundary that are causing a pressure imbalance.
- To the best of your ability, ducts located outside the thermal boundary should be sealed to a pressure pan reading of 1 pa or less.
- The reduction you achieve depends on your ability to find the leaks and whether you can access the leaky ducts.
- After duct sealing, make sure airflow is still adequate for heating and cooling systems. Recheck temperature rise on heating systems and airflow for heat pumps and air conditioners.

Supply and return terminations found outside the conditioned space are to be removed and the ducts sealed. Removal of unnecessary ducts in unconditioned spaces is recommended.

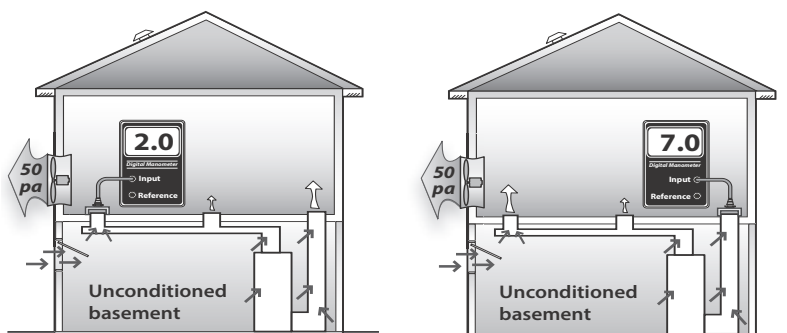

Pressure pan test: A pressure pan reading of 2 indicates moderate duct air leakage in the supply ducts.

Problem return register: A pressure reading of 7 pascals indicates major air leakage near the tested register.

8.14.2 Measuring Duct Air Leakage with a Duct Blower

The duct blower is the most accurate common measuring device for duct air leakage. It consists of a fan, a digital manometer or set of analog manometers, and a set of reducer plates for measuring different leakage levels.

Pressurizing the ducts with a duct blaster measures total duct leakage. Using a blower door with a duct blower measures leakage to outdoors.

Measuring Total Duct Leakage

The total duct leakage test measures leakage to both indoors and outdoors. The house and intermediate zones should be open to the outdoors by way of windows, doors, or vents. Opening the intermediate zones to outdoors insures that the duct blower is measuring only the ducts' airtightness — not the airtightness of

ducts combined with other air barriers like roofs, foundation walls, or garages.

Supply and return ducts can be tested separately, either before the air handler is installed in a new home or when an air handler is removed during replacement.

Follow these steps when performing a duct airtightness test.

1. Install the duct blower in the air handler or to a large return register, either using its connector duct or simply attaching the duct blower itself to the air handler or return register with cardboard and tape.
2. Remove the air filter(s) from the duct system.
3. Seal all supply and return registers with masking tape or other non-destructive sealant.
4. Open the house, basement or crawl space, containing ducts, to outdoors.
5. Drill a $1/4$ or $5/16$ -inch hole into a supply duct a short distance away from the air handler and insert a manometer hose. Connect a manometer to this hose to measure *duct with reference to (WRT) outdoors*. (Indoors, outdoors, and intermediate zones should ideally be opened to each other in this test).
6. Connect an airflow manometer to measure *fan WRT the area near the fan*.

Check manometer(s) for proper settings. Digital manometers require your choosing the correct mode, range, and fan-type settings.

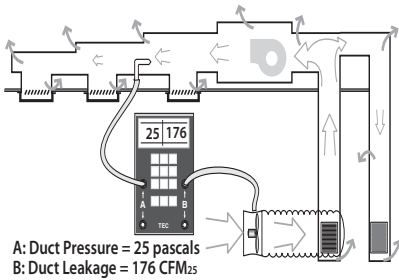

Total duct air leakage measured by the duct blower: All registers are sealed except the one connecting the duct blower to the system. Pressurize the ducts to 25 pascals and measure airflow.

1. Turn on the duct blower and pressurize the ducts to 25 pascals.
2. Record duct-blower airflow.
3. While the ducts are pressurized, start at the air handler and move outward feeling for leaks in the air handler, main ducts, and branches.
4. After testing and associated air-sealing are complete, restore filter(s), remove seals from registers, and check air handler.

Measuring Duct Leakage to Outdoors

Measuring duct leakage to outdoors gives you a duct-air-leakage value that is directly related to energy waste and the potential for energy savings.

1. Set up the home in its typical heating and cooling mode with windows and outside doors closed. Open all indoor conditioned areas to one another.
2. Install a blower door, configured to pressurize the home.
3. Connect the duct blower to the air handler or to a main return duct.
4. Pressurize the ducts to +25 pascals by increasing the duct blower's speed until this value is reached.

5. Pressurize the house until the pressure difference between the house and ducts is 0 pascals (*house WRT ducts*). See "*Blower-Door Test Procedures*" on page 506.
6. Read the airflow through the duct blower. This value is duct leakage to outdoors.

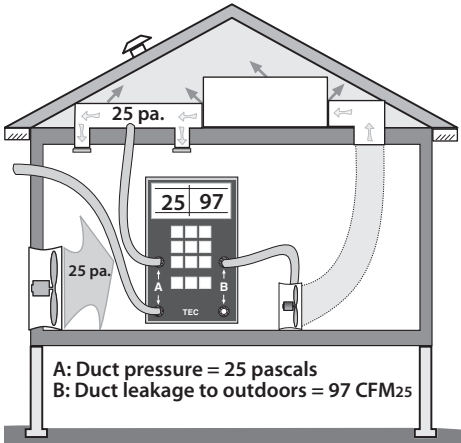

Measuring duct leakage to outdoors: Using a blower door to pressurize the house with a duct blower to pressurize the ducts measures leakage to the outdoors — a smaller number and a better predictor of energy savings. This test is preferred for evaluating duct leakage for specialists in both shell air leakage and duct air leakage whenever a blower door is available.

8.14.3 Measuring House Pressure Caused by Duct Leakage

The following test measures pressure differences between the house and outdoors, caused by duct leakage. Try to correct pressure differences because of the air leakage through the building enclosure that the pressure differences create.

1. Close all windows and exterior doors. Turn-off all exhaust fans.
2. Open all interior doors, including door to basement.
3. Measure the baseline house-to-outdoors pressure difference and zero it out using the baseline procedures
4. Turn on air handler.

5. Measure the house-to-outdoors pressure difference. This test indicates dominant duct leakage as shown here.

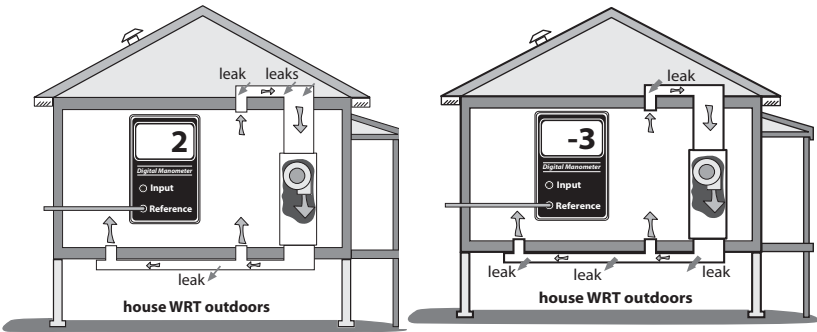

Dominant return leaks: When return leaks are larger than supply leaks, the house shows a positive pressure with reference to the outdoors.

Dominant supply leaks: When supply leaks are larger than return leaks, the house shows a negative pressure with reference to the outdoors.

A positive pressure indicates that the return ducts (which pull air from leaky intermediate zones) are leakier than the supply ducts. A negative pressure indicates that the supply ducts (which push air into intermediate zones through their leaks) are leakier than return ducts. A pressure at or near zero indicates equal supply and return leakage or very little duct leakage.

8.15 SEALING DUCT LEAKS

Seal ducts located outside the thermal boundary or in an intermediate zone like a ventilated attic or crawl space. Leaks nearer to the air handler are exposed to higher pressure and are more important than leaks farther away.

8.15.1 General Duct-Sealing Methods

Duct sealers install duct mastic and fiberglass mesh to seal duct leaks. When they need reinforcement or temporary closure, the

duct sealers use fiberglass mesh, tape, or sheet metal. Observe these three standards.

1. Seal seams, cracks, joints, and holes less than $\frac{1}{4}$ inch, using mastic and fiberglass mesh.
2. Bridge seams, cracks, joints, holes, and penetrations, between $\frac{1}{4}$ and $\frac{3}{4}$ inch, with sheet metal or tape and then cover the metal or tape completely with mastic, reinforced by mesh at seams in the sheet metal or tape.
3. Overlap the mastic and mesh at least one inch beyond the seams, repairs, and reinforced areas of the ducts.

8.15.2 Sealing Return Ducts

SWS Detail: 5.0106 Duct Sealing; 5.0106.1 General Duct Sealing; 5.0106.2 Duct Sealing-SPF; 5.0106.3 Duct Sealing-Proprietary Spray Application

Return leaks are important for combustion safety and for efficiency. Use the following techniques to seal return ducts.

- ✓ First, seal all return leaks within the combustion zone to prevent this leakage from depressurizing the CAZ and causing backdrafting.
- ✓ Seal all return ducts in crawl spaces for indoor air quality.
- ✓ Seal panned return ducts using mastic to seal all cracks and gaps within the return duct and register. Remove the panning to seal cavities containing joints in building materials. A preferable option might be to replace structural returns with dedicated return ducts.
- ✓ Carefully examine and seal leaks at transitions between panned floor joists and metal trunks that change the direction of the return ducts. You may need a mirror to find some of the biggest return duct leaks in these areas.

- ✓ Seal filter slots with a tight-fitting, durable, user-friendly filter-slot cover to allow easy removal for filter-changing.
- ✓ Seal the joint between the furnace and return plenum with silicone caulking or foil tape.

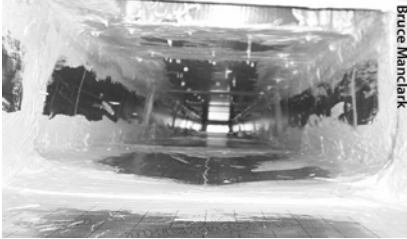

Lining a panned cavity: Foil-faced foam board designed for lining duct cavities is sealed with duct mastic to provide an airtight, insulated return.

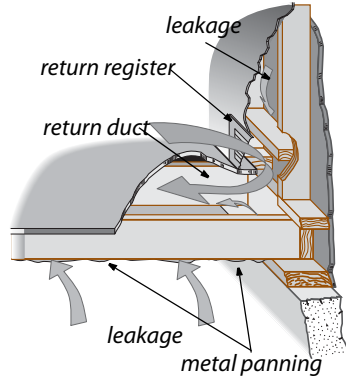

Panned floor joists: These return ducts are often very leaky and may require removing the panning to seal the cavity.



Pedestal return air: These return plenums are often very leaky and may require removing a panel to seal the leaks from inside.

8.15.3 Sealing Supply Ducts

SWS Detail: 5.0106 Duct Sealing; 5.0106.1 General Duct Sealing; 5.0106.2 Duct Sealing-SPF; 5.0106.3 Duct Sealing-Proprietary Spray Application

Inspect these places in the duct system and seal them as needed.

- ✓ *Plenum joint at air handler:* Technicians might have had problems sealing these joints because of a lack of space. Seal these plenum connections thoroughly even if you must cut an access hole in the plenum. Use silicone caulking or foil tape instead of mastic and fabric mesh here for future access — furnace replacement, for example.

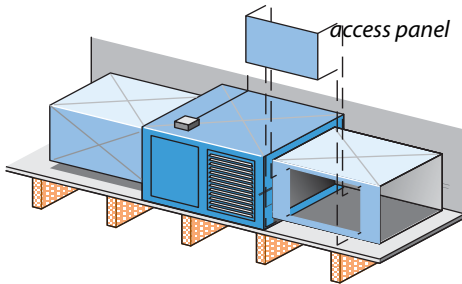

Plenums, poorly sealed to air handler: When air handlers are installed in tight spaces, plenums may be poorly fastened and sealed. Cutting a hole in the duct may be the only way to seal this important joint.

Sectioned elbows: Joints in sectioned elbows, known as gores, are usually leaky and require sealing with duct mastic.

- ✓ *Joints at branch takeoffs:* Seal these important joints with a thick layer of mastic. Fabric mesh tape should cover gaps and reinforce the seal at gaps.
- ✓ *Joints in sectioned elbows:* Known as gores, these are usually leaky and require sealing with duct mastic.
- ✓ *Tabbed sleeves:* Attach the sleeve to the main duct with 3-to-5 screws and apply mastic plentifully. Or better, remove the tabbed sleeve and replace it with a manufactured take-off, which is easier to seal.
- ✓ *Flexduct-to-metal joints:* Apply a 2-inch band of mastic to the end of the metal connector. Attach the flexduct's inner liner with a plastic strap, tightening it with a strap tensioner. Attach the insulation and outer liner with another strap.
- ✓ *Damaged flex duct:* Replace flex duct when it is punctured, deteriorated, or otherwise damaged.

- ✓ *Deteriorating ductboard facing:* Replace ductboard, preferably with metal ducting, when the facing deteriorates because this deterioration leads to excessive air leakage.

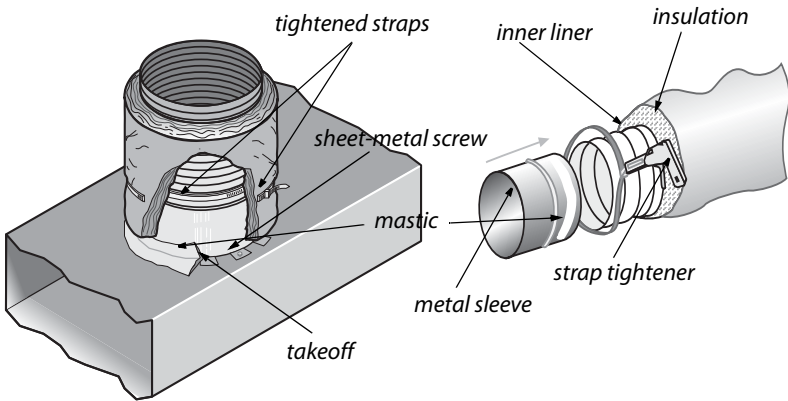

Flexduct joints: Flexduct itself is usually fairly airtight, but joints, sealed improperly with tape, can be very leaky. Use methods shown here to make flexduct joints airtight.

- ✓ Consider closing supply and return registers in unoccupied basements or crawl spaces.
- ✓ Seal the joint between the boot and the ceiling, wall, or floor between conditioned and unconditioned areas.

Duct Support

- ✓ Support rigid ducts and duct joints with duct hangers at least every 5 feet or as necessary to prevent sagging of more than one-half inch.
- ✓ Support duct board or flex duct every 4 feet using a minimum of 1 ½" wide support material.



Sealing register boots: Seal between the boot and floor. Seal joints inside the boot.

8.15.4 Materials for Duct Sealing

Duct mastic is the best duct-sealing material because of its superior durability and adhesion. Apply mastic at least $\frac{1}{16}$ -inch thick, and use reinforcing mesh for all joints wider than $\frac{1}{8}$ -inch or joints that may move. Install screws to prevent joint movement or separation.

Aluminum foil or cloth duct tape aren't good materials for duct sealing because their adhesive often fails. Cover any tape with mastic extending 1" past the edges of the tape to prevent tape's adhesive from drying out and failing. Any tape that is used as part of an assembly it should be UL 181 rated

8.16 DUCT INSULATION

SWS Detail: 5.0104 Duct Installation; 5.0107 Duct Insulation

Insulate supply ducts that are installed in unconditioned areas outside the thermal boundary such as crawl spaces, attics, and attached garages with vinyl- or foil-faced duct insulation. Don't insulate ducts that run through conditioned areas unless they cause overheating in winter or condensation in summer. Use these best practices for installing insulation.

- ✓ Always perform necessary duct sealing before insulating ducts.

- ✓ Duct-insulation R-value must be $\geq R-8$.
- ✓ It is not cost-effective to remove existing R-4 flex ducts and replace them with R-8. If possible, cover with insulation, if added, as appropriate.
- ✓ Insulation should cover all exposed supply ducts, with no significant areas of bare duct left uninsulated.

Duct insulation:
Insulate supply ducts, located in unheated areas, to a minimum of R-8.

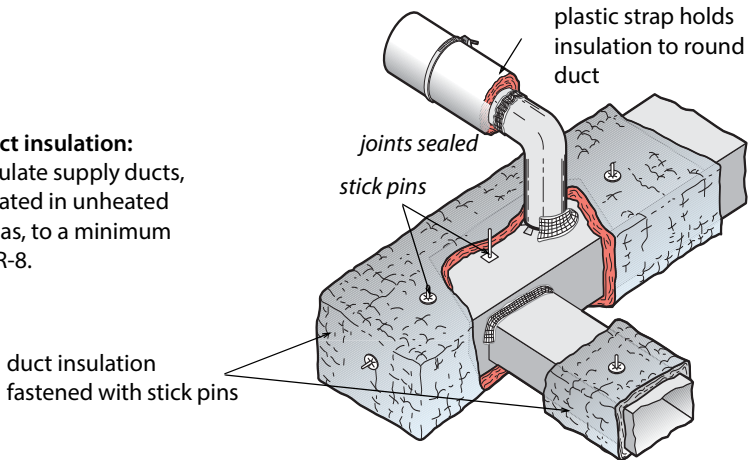

- ✓ Insulation's compressed thickness must be more than 75% of its uncompressed thickness. Don't compress duct insulation excessively at corner bends.
- ✓ Fasten insulation using mechanical means such as stick pins, twine, staples, or plastic straps.
- ✓ Cover the insulation's joints with tape to stop air convection.
- ✓ Install the duct insulation 3 inches away from heat-producing devices such as recessed light fixtures.

Caution: Burying ducts in attic insulation is common in some regions and it reduces energy losses from ducts. However, condensation on ducts in humid climates is common during the air-conditioning season, so don't allow cellulose to touch metal ducts to avoid corrosion from cellulose's ammonium sulfate fire retardant.

Important Note: Tape can be effective for covering joints in the insulation to prevent air convection, but the tape fails when expected to resist the force of the insulation's compression or weight. Outward-clinch staples or plastic straps can help hold the insulation facing and tape together.

8.16.1 Spray Foam Duct Insulation

SWS Details: 5.0107.2 Duct Insulation - SPF

High-density spray foam insulation is also a good duct-insulation option, assuming it is listed as ASTM E-84 or UL 723. Spray foam is particularly helpful in areas where the foam can seal seams and insulate in one application. However, the spray foam application is limited by space around the duct to a greater degree than wrapping with fiberglass blankets.

8.17 HOT-WATER SPACE-HEATING DISTRIBUTION

The most significant energy wasters in hot water systems are poor steady state efficiency, off cycle flue losses stealing heat from the stored water, and boilers operating at a too high water temperature.

8.17.1 Boiler Efficiency and Maintenance

SWS Details: 5.0203.1 Boilers; 5.0204 Clean and Tune; 5.0204.1 Fuel Fired Boilers; Boiler Room Water Drainage

Monitor boiler performance and efficiency by inspecting for these problems.

- Corrosion, scaling, and dirt on the water side of the heat exchanger.

- Corrosion, dust, and dirt on the fire side of the heat exchanger.
- Excess air during combustion from air leaks and incorrect fuel-air mixture.
- Off-cycle air circulation through the firebox and heat exchanger, removing heat from stored water.

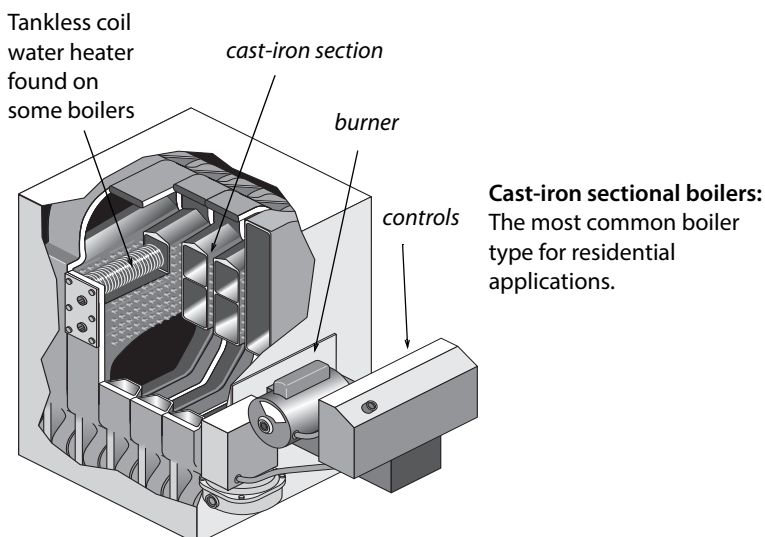

Boiler Efficiency Improvements

Consider the following maintenance and efficiency improvements for both hot-water and steam boilers based on boiler inspection.

- ✓ Check for leaks on the boiler, around its fittings, or on any of the distribution piping connected to the boiler.
- ✓ Clean fire side of heat exchanger of noticeable dirt.
- ✓ Drain water from the boiler drain until the water flows clean. Then add water to refill the system.

8.17.2 Hydronic Distribution System Improvements

SWS Details: 5.02 Hydronic; 5.0201 Controls; 5.0201.1 Thermostat Replacement; 5.0202 Distribution; 5.0202.1 Radiator Reflector; 5.0202.2 Distribution Insulation; 5.0203 Equipment Installation; 5.0204 Clean and Tune

Hydronic distribution systems consist of the supply and return piping, the circulator, expansion tank, air separator, air vents, and heat emitters. A properly designed and installed hydronic distribution system can operate for decades without service. However, many systems have installation flaws or need service.

Note: You can recognize a hot-water boiler by its expansion tank, located somewhere above the boiler. The expansion tank provides an air cushion to allow the system's water to expand and contract as it is heated and cooled. Without a functioning expansion tank excessive pressure in the boiler discharges water through the pressure-relief valve.

Safety Checks and Improvements

Work with contractors and technicians to specify and verify the following safety and efficiency tests and inspections.

- ✓ Verify the existence of a 30-psi-rated pressure relief valve. The pressure relief valve should have a drain pipe that terminates 6 inches from the floor. Replace a malfunctioning valve, or install a pressure relief valve if none exists. Look for signs of leakage or discharges from that valve. Find out why the pressure relief valve is discharging.
- ✓ Verify that the expansion tank isn't waterlogged or isn't too small for the system. A waterlogged expansion tank can make the pressure relief valve discharge. Measure the expansion tank's air pressure. A common pressure for one

and two-story buildings is 12 psi. The pressure in taller buildings should be approximately one (1) psi per 2.3 feet of the distribution system's height.

- ✓ If you observe rust in venting, verify that the return water temperature is warmer than 130°F for gas and warmer than 140°F for oil. These minimum water temperatures prevent acidic condensation.
- ✓ Verify that high-limit control disengages the burner at a water temperature of 200°F or less.
- ✓ Lubricate circulator pump(s) if necessary.

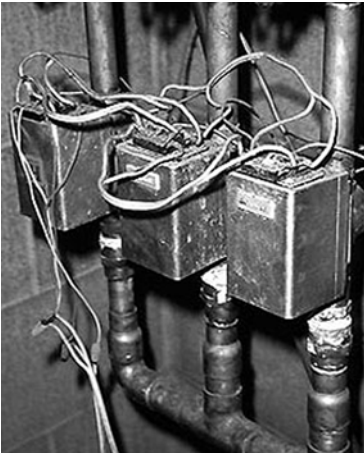

Zone valves: Separate thermostats control each zone valve. Zone valves have switches that activate the burner.

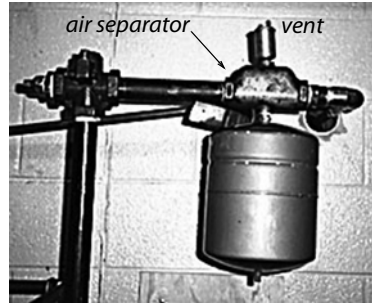

Expansion tank, air separator, and vent: Preventing excessive pressure and eliminating air from the systems are important for hydronic distribution systems.

Simple Efficiency Improvements

Do the following energy-efficiency improvements.

- ✓ Repair water leaks in the system.
- ✓ Remove corrosion, dust, and dirt on the fire side of the heat exchanger.

- ✓ Check for excess air during combustion from air leaks and incorrect fuel-air mixture. *See “Critical Combustion-Testing Parameters”*
- ✓ Bleed air from radiators and piping through air vents on piping or radiators. Most systems fill automatically through a shutoff and pressure-reducing valve connected to the building’s water supply. If there is a shutoff and no pressure-reducing valve, install one and set it to the hydronic-system pressure. Then check the system pressure at the expansion tank, and adjust the pressure as necessary.

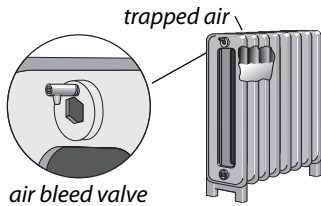

Purging air: Trapped air collects at the hot-water system’s highest parts. Bleeding air from radiators fills the radiator and gives it more heating surface area.

- ✓ Vacuum and clean fins of fin-tube convectors if you notice dust and dirt there.
- ✓ Insulate all supply and return piping, passing through unheated areas, with appropriate pipe insulation, at least one-inch thick, rated for temperatures up to 200° F.

Improvements to Boiler Controls

Consider these improvements to control systems for hot-water boilers.

- ✓ Install outdoor reset controllers to regulate water temperature, depending on outdoor temperature.
- ✓ If possible, operate the boiler without a low-limit control for maintaining a minimum boiler-water temperature. If the boiler heats domestic water in addition to space heating, the low-limit control may be necessary.
- ✓ After control improvements like two-stage thermostats or reset controllers, verify that return water temperature is

high enough to prevent condensation and corrosion in the chimney as noted previously.

- ✓ Install electric vent dampers on natural-draft gas- and oil-fired high-mass boilers.

8.18 STEAM HEATING AND DISTRIBUTION

Steam heating is less efficient than hot-water heating because steam requires higher temperatures than hot water. For single-family homes, consider replacing a steam heating system with a hot-water or forced-air system. Multifamily buildings, especially multi-story buildings, may have little choice but to continue with steam because of the high cost of switching systems.

Note: You can recognize a steam boiler by its sight glass, which indicates the boiler's water level. Notice that the water doesn't completely fill the boiler, but instead allows a space for the steam to form above the boiler's water level.

8.18.1 Steam Pressure Limits

If the steam-heating system remains, operate it at the lowest steam pressure that heats the building adequately. Two psi on the boiler-pressure gauge is a practical limit for many systems although some systems can operate at pressures down to a few ounces per square inch of pressure. Traps and air vents are crucial to operating at a low steam pressure.

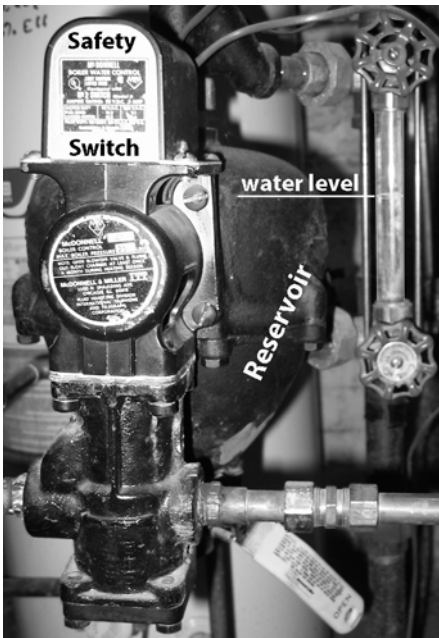

Sight glass & low-water control: The sight glass shows the boiler water level. The low water control adds water to the boiler and extinguishes the burner if the water level is too low.

8.18.2 Steam System Maintenance

Do these safety and maintenance tasks on steam systems.

- ✓ Verify that steam boilers have functioning high-pressure limits and low-water cut-off controls.
- ✓ Verify the function of the low-water cutoff by flushing the low-water cutoff with the burner operating. Combustion should stop when the water level in the boiler drops below the level of the float. If combustion continues, repair or replace the low-water cutoff.

- ✓ Verify that flush valves on low-water cutoffs are operable and don't leak water.
- ✓ Ask owner about instituting a schedule of blow-down and chemical-level checks.
- ✓ Specify that technicians drain mud legs on return piping.

8.18.3 Steam System Energy Conservation

Specify the following efficiency checks and improvements for steam systems.

Electric vent dampers reduce off-cycle losses for both gas- and oil-fired steam systems.

One-Pipe Steam

- ✓ Verify that high-pressure limit control is set at or below 1 (one) psi or as low as acceptable in providing heat to the far ends of the building.
- ✓ Verify that air vents function and that all steam radiators receive steam during every cycle. Air vents release air to make room for steam. Major pipe risers and all radiators should have vents.
- ✓ Unplug air vents or replace malfunctioning vents as necessary. Add vents to steam lines and radiators as needed to get steam to all the registers.
- ✓ Radiator air vents should be open to release air while the system is filling with steam, then closed when steam reaches the vents. Steam need not fill radiators on every cycle. In mild weather, steam partly fills radiators before the boiler cycles off.

- ✓ Replace malfunctioning radiator air vents as necessary. However, don't over-vent radiators because this can cause overheating and water hammer from too much steam condensing.

One-pipe and two-pipe steam systems: Still common in multifamily buildings, one-pipe steam works best when very low pressure steam can drive air out of the piping and radiators quickly through plentiful vents. Vents are located on each radiator and also on main steam lines.

Two-pipe steam systems: Radiator traps keep steam inside radiators until it condenses. No steam should be present at the condensate tank.

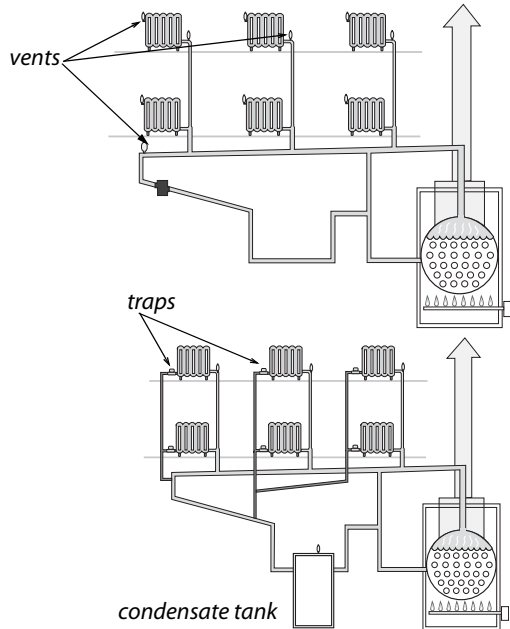

Two-Pipe Steam: General Improvements

- ✓ Consider a modern high-efficiency power burner and electric vent damper as retrofits for steam boilers.
- ✓ Clean fire side of heat exchanger of noticeable dirt.
- ✓ Insulate all steam piping that passes through unconditioned areas to at least R-3 with fiberglass or specially designed foam pipe insulation rated for steam piping.
- ✓ Consider installing remote sensing thermostats that vary cycle length according to outdoor temperature and include night-setback capability.

Two-Pipe Steam: Traps and Orifices

- ✓ Inspect return lines and condensate receiver for steam coming back to the boiler, which is a sign of leaky traps. Check radiator and main line traps for steam leakage.
- ✓ Check steam traps with a digital thermometer or listening device to detect any steam escaping from radiators through the condensate return. Replace leaking steam traps or their thermostatic elements.
- ✓ When you can gain access to all the system's steam traps, repair leaking steam traps or replace them. Replace all failed traps at the same time to prevent new traps failing because of water hammer from steam leakage through neighboring failed traps.
- ✓ The only 100% reliable way to test a steam trap is to connect it to a test apparatus and see if it allows steam to pass. However if you have an accurate thermometer, the temperature on the radiator side of a functioning trap should be more than 215°F and the temperature on the return side of that trap should be less than 205°F when steam occupies the radiator.
- ✓ When you can't gain access to all the system's steam traps at the same time, consider abandoning failed steam traps and installing radiator-inlet orifices in two-pipe steam radiators. The orifices limit steam flow to an amount that can condense within the radiator. Orifices can also reduce steam delivery to oversized radiators by 20% or a little more.

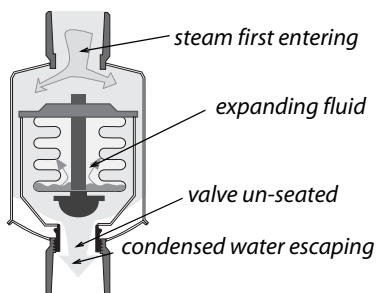

Steam traps: Steam enters the steam trap heating its element and expanding the fluid inside. The expanded element plugs the steam's escape with a valve.

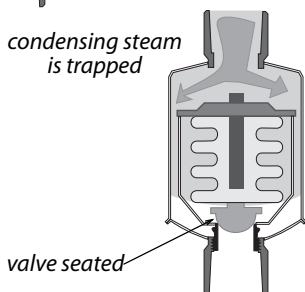

Two-Pipe Steam: Thermostatic Radiator Valves

Consider controlling radiators with thermostatic radiator valves (TRVs) except for radiators in the coolest rooms. TRVs can be used with systems equipped with either traps or orifices.

For effective temperature control, locate the thermostatic element of the TRVs in the path of cool air moving toward the radiator or convector. TRVs are available with sensors located remotely from the valve, which solves the problem of a valve located where the radiator heats a valve-mounted sensor, fooling it into closing.

8.18.4 Converting Steam Distribution to Hot Water

Quite a few steam systems have been converted to hot water distribution over the years by using the existing distribution piping, radiators, or both. Although some of these systems work well, many have problems. Converting steam to hot water has a number of potential problems, including the following.

- The conversion increases the operating pressure of the old pipes by a factor of 10 and this could cause leaks.
- In two-pipe systems, the return may not be large enough and require re-piping.
- In one-pipe steam the return must be installed to every radiator.
- The steam radiators may not be large enough to heat adequately with hot water.
- The existing radiators may be the type that won't work with hot water.

For these reasons, it's better to fix the steam system than to convert the system to hot water.

8.19 PROGRAMMABLE THERMOSTATS

SWS Details: 5.0101.1 Thermostat Replacement

A programmable thermostat may be a big energy saver if the building's occupants understand how to program it. A programmable thermostat won't save any energy if occupants already control day and night temperatures effectively.

If you replace the existing thermostat, as a part of weatherization work, discuss programmable thermostats with occupants. If they can use a programmable thermostat effectively, then install one. Educate occupants on the use of the thermostat and leave a copy of manufacturer's directions with them.

Inside a programmable thermostat:

In addition to the instructions on the exterior of this thermostat are instructions inside for setting the heat anticipator.

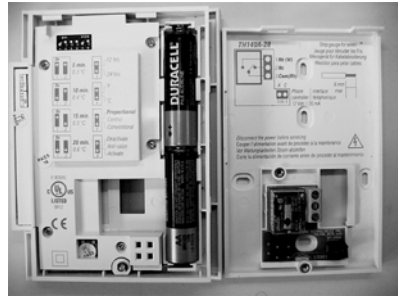

Many models of programmable thermostats have settings that you select from inside the thermostat. These settings include the heat-anticipator setting, which adjusts the cycle length of the heating or cooling system.

Important: Dispose of mercury-containing thermostats according to EPA guidance.

8.20 ELECTRIC HEAT

Electric heaters are usually 100% efficient at converting the electricity to heat in the room where they are located. Electric heat is inherently inefficient because of the low efficiency of fossil fuel electric power plants, which is why electricity is comparatively expensive as a heating option.

8.20.1 Electric Baseboard Heat

Electric baseboard heaters are zonal heaters controlled by thermostats within the zone they heat. Electric baseboard heat can help to minimize energy costs, if residents take advantage of the ability to heat by zones.

Baseboard heaters contain electric resistance heating elements encased in metal pipes. These are surrounded by aluminum fins to aid heat transfer. As air within the heater is heated, it rises

into the room. This draws cooler air into the bottom of the heater.

- ✓ Make sure that the baseboard heater sits at least an inch above the floor to facilitate good air convection.
- ✓ Clean fins and remove dust and debris from around and under the baseboard heaters as often as necessary.
- ✓ Avoid putting furniture directly against the heaters. To heat properly, there must be space for air convection.

The line-voltage thermostats used with baseboard heaters sometimes may not provide good comfort because they allow the room temperature to vary by 2°F or more. Newer, more accurate line-voltage thermostats are available with a positive-off feature that prevents unintentional heating during mild weather.

Programmable thermostats for electric resistance increase and reduce the temperature automatically.

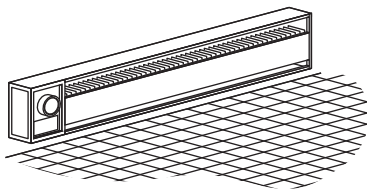

Electric baseboard: Electric baseboard is more efficient than an electric furnace and sometimes even outperforms a central heat pump because it is easily zone-able. The energy bill is determined by the habits of the occupants and the energy efficiency of the building.

8.20.2 Electric Furnaces

An electric furnace is usually the most expensive way to heat a building because electricity is relatively expensive and because of furnace duct losses.

Electric furnaces heat air moved by its fan over several electric-resistance heating elements. Electric furnaces have two to six elements — 3.5 to 7 kW each — that work like the elements in a toaster.

The 24-volt thermostat circuit energizes devices called sequencers that bring the 240 volt heating elements on in stages when the thermostat calls for heat. The multispeed fan switches to higher speeds as more elements engage to keep the air temperature stable.

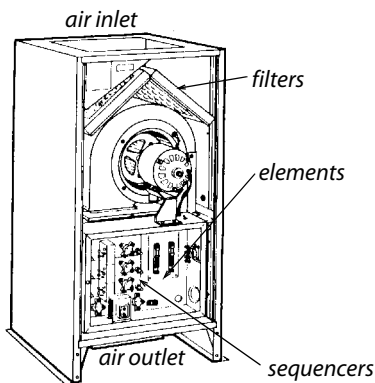

Electric furnace: A squirrel-cage blower blows air over 2 to 6 electric resistance coils and down into the plenum below the floor.

8.20.3 Central Heat-Pump Energy Efficiency

Heat pumps move heat with refrigeration rather than converting it from the chemical energy of a fuel. An air-source heat pump is almost identical to an air conditioner, except for a reversing valve that allows refrigerant to follow two different paths, one for heating and one for cooling.

Like air conditioners, air-source heat pumps are available as centralized units with ducts or as room units. Heat pumps are 1.5 to 3 times more efficient than electric furnaces. Heat pumps can compete with combustion furnaces for comfort and value, but only with proper installation.

Heat pump: The air handler contains a blower, indoor coil, strip heat, and often a filter. Static pressure and temperature rise are two indicators of performance.

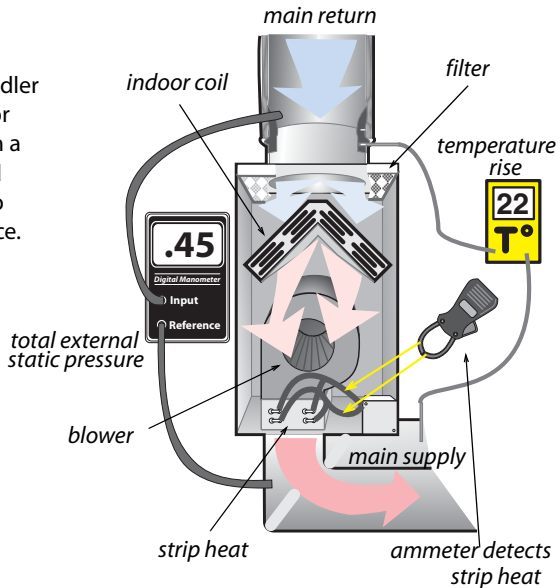

Heat pumps contain auxiliary electric resistance heating coils, known as strip heat. The energy efficiency of a heat pump depends on how much of the heating load the compressor provides compared to the strip heat.

Evaluating Heat Pumps During the Heating Season

Heat pumps should have two-stage thermostats designed for use with heat pumps. The first stage is compressor heating and the second stage is the inefficient strip heat.

Although we can generally evaluate the heat pumps refrigerant charge in the winter, it may be necessary to return in warm weather to more accurately charge the system. This summer verification is required with new heat-pump installations.

Consider these steps to evaluate conventional single-stage heat pumps during the winter.

- ✓ Measure the airflow of the air handler by temperature rise method, flow plate, or flow hood. Heat pumps must have 400 cfm +/- 10% per ton.

- ✓ With only the heat pump operating and the supplemental heat off, look for a temperature rise of approximately 20°F when the outdoor temperature is 32°F. Add or remove 1° of temperature rise for every 3° that the outdoor temperature is over or under 32°F.
- ✓ Check for strip-heat operation by measuring amperage. Then use the chart shown here to find out if strip heat is operating.

Is strip heat activated? Using an ammeter and the nameplate data on the heat pump, a technician can know when and if the strip heat is activated.

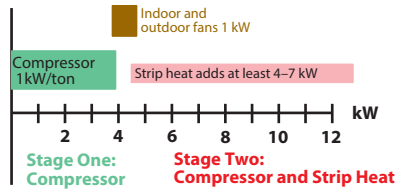

- ✓ External static pressure should be 0.5 IWC (125 pascals) or less for older, fixed-speed blowers and less than 0.7 IWC (200 pascals) for variable-speed blowers. Lower external static pressure promotes higher airflow.
- ✓ Seal supply and return ducts and insulate them after you've verified the airflow as adequate. Measure airflow again after duct sealing if the ducts were very leaky.

Most residential central heat pumps are split systems with the indoor coil and air handler indoors and outdoor coil and compressor outdoors. Individual room heat pumps are more efficient since they don't have ducts, and are factory-charged with refrigerant.

In the summer, use the same procedures to evaluate central heat pumps as to evaluate central air conditioners.

display will indicate when auxiliary or emergency heat are active



emergency heat switch

Heat pump thermostat: These should have two indicator lights, one for auxiliary heat and one for emergency heat.

filter bracket
indoor coil

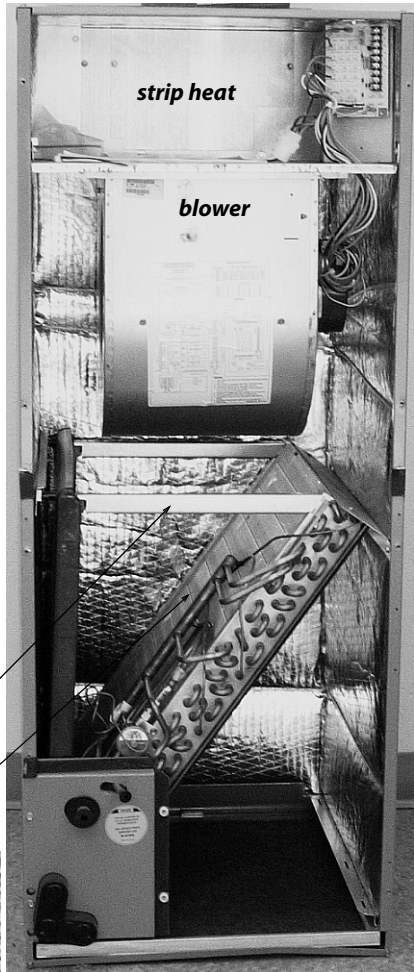

Heat pump: This upflow indoor air handler contains a blower, indoor coil, strip heat, and filter bracket.

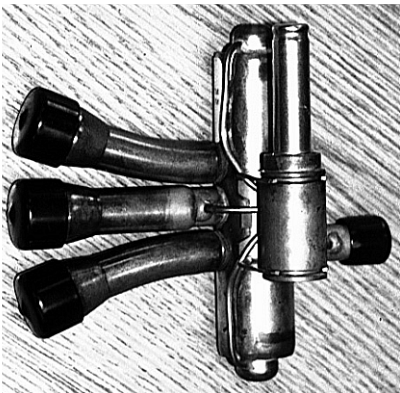

Reversing valve: The outdoor unit contains a reversing valve installed near the compressor.

The illustration shows features of an energy-efficient heat pump installation.

Multiple returns ensure good airflow to all parts of the home.

Outdoor thermostat prevents strip heat from operating until outdoor temperature is less than 40°F. Thermostat stages elements as needed.

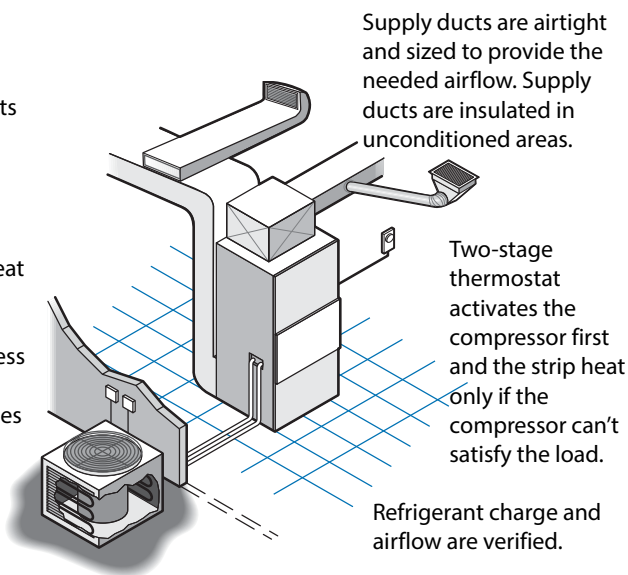

Coil is cleaned every year. Weeds, grass and shrubs shouldn't grow within 3 feet. Verify that no airflow restrictions exist above the outdoor unit.

8.20.4 Room Heat Pumps

SWS Detail: 5.03 Non-Distributed; 5.0301 Room Conditioning; 5.0301.1 Through Wall and Window Unit; 5.0301.2 PTAC/PTHP Units; 5.0301.3 Wall Furnace

Room heat pumps can provide all or part of the heating and cooling needs for small homes and apartments. These one piece room systems (also known as terminal systems) look like a room air conditioner, but provide heating as well as cooling. They can also provide ventilation air when the space requires neither heating nor cooling. They mount in a window or through a framed opening in a wall.

Room (or unitary) heat pumps can be a good choice for replacing existing unvented gas space heaters. Their fuel costs are somewhat higher than gas space heaters, but they are safer than combustion appliances.

Room heat pumps have an efficiency over central furnaces or central boilers because they heat a single zone and don't have the delivery losses. If room heat pumps replace electric resistance heat, they consume only one-half to one-third the electricity to produce the same amount of heat.

Room heat pumps draw a substantial electrical load, and may require 240-volt wiring. Provide a dedicated electric circuit that can supply the equipment's rated electrical input. Insufficient wiring capacity can result in dangerous overheating, tripped circuit breakers, blown fuses, or motor-damaging voltage drops. In most cases, a licensed electrician should confirm that the house wiring is sufficient. Don't operate room heat pumps with extension cords or plug adapters.

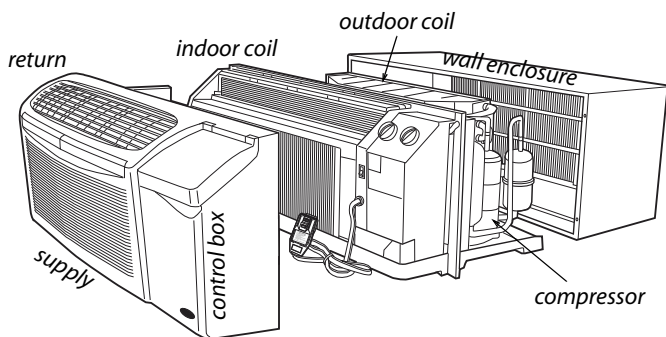

Unitary heat pumps: These unitary ductless heat pumps sit inside an exterior wall. They are a very efficient kind of electric heating and cooling.



8.20.5 Ductless Minisplit Heat Pumps

SWS Detail: 5.03 Non-Distributed

Ductless minisplit heat pumps contain an outdoor condenser and one or more indoor fan-coil units that heat or cool the rooms. Mini-split heat pumps are among the most efficient heating and cooling systems available.

Ducted mini-splits have become popular for retrofitting multi-family buildings. Variable refrigerant flow (VRF) systems employ a computerized valving unit to distribute the correct amount of refrigerant to each terminal unit or head in large buildings.

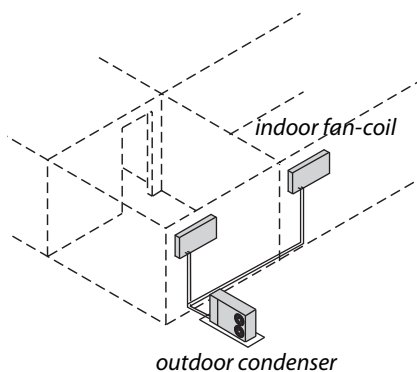

Ductless mini-split heat pumps:
These systems have very high efficiency: 200% to 400%.

Consider minisplits heat pumps or VRF systems as replacement HVAC solutions when they are appropriate, for example.

- Buildings currently having no ducts.
- Buildings with poorly designed or deteriorating ducts outside the thermal boundary or located in areas, such as floor cavities and on roofs.
- Isolated parts of building such as additions or previously unconditioned areas.

- Very well-insulated, airtight, and shaded buildings.
- Rooms needing cooling in buildings with no central air conditioning.
- Masonry buildings, often multifamily, being retrofitted to replace obsolete central space-conditioning systems, for example: steam or obsolete packaged systems.

8.21 EVALUATING DUCTED CENTRAL AIR-CONDITIONING SYSTEMS

An energy-efficient home shouldn't need more than a ton of air-conditioning capacity for every 1000 square feet of floor space depending on climate zone. Window shading, attic insulation, and air leakage should be evaluated together with air-conditioner performance to size an air conditioner.

The following four installation-related problems are characteristic of central air conditioning systems.

1. Inadequate airflow
2. Duct air leakage
3. Incorrect charge
4. Over sizing

Refrigerant-charge testing and adjustment come after duct testing and sealing, which comes after airflow measurement and improvement.

The recommended airflow rate for central air-conditioning systems is between 350 CFM and 450 CFM per ton of refrigeration capacity. Heat pump airflow rate should be between 400 CFM and 450 CFM per ton.

Table 8-15: Compiled Research Results on HVAC Performance^a

Installation-Related Problem	%^b	Savings Potential
Duct air leakage (avg. 270 CFM ₂₅) ^c	70%	17% avg.
Inadequate airflow	70%	7% avg.
Incorrect charge	74%	12% avg.
Oversized by 50% or more	47%	2–10%

- a. Report sponsored by Environmental Protection Agency (EPA) and compiled from research from Multiple Field Studies
- b. Percent of tested homes found with a significant problem.
- c. The number of homes of the duct-leakage studies was around 14,000; the number for the other problems was over 400 each.

8.21.1 Central A/C-Heat Pump Inspection and Maintenance

Air conditioners move a lot of air and that air contains dust. The filter in the air handler catches most large dust particles. However some dust travels around or through the filter, depending on the filter and its mounting assembly. The condenser coil outdoors isn't protected by a filter and is usually quite dirty.

Cleaning the Condenser Coil

Dirt enters the coil from the outside. The goal of this procedure is to drive the dirt out by spraying inside to outside. With high-pressure water, however, you can drive the dirt through the coil and into the cabinet where it drains out through drain holes.

- ✓ Inspect the condenser coil and know that it is probably dirty even if it looks clean on the outside.

- ✓ Use a stiff-bristle brush to remove visible surface dirt from the outside of the condenser coil.
- ✓ Apply a biodegradable coil cleaner to the outside of the coil. Then spray cold water through the coil, preferably from inside the cabinet. Many coils can tolerate a high-pressure spray but others need low-pressure spray to avoid bending the fins.
- ✓ Straighten bent fins with a fin comb.

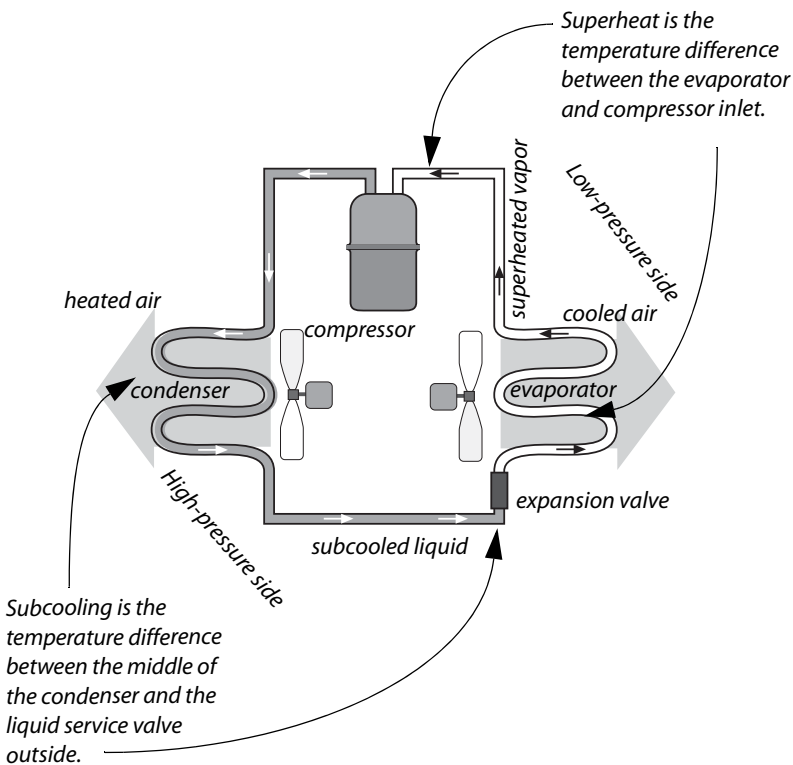

Cleaning the Evaporator Coil

Dirt enters the filter, blower, and coil from the return plenum.

- ✓ Inspect the filter slot in the air handler or the filter grille in the return air registers.
- ✓ Inspect the blower in the air handler after disconnecting power to the unit. Can you remove significant dirt from one of the blower blades with your finger? If the blower is dirty, then the evaporator coil is also dirty.
- ✓ Clean the blower and evaporator. Remove surface dirt and dust off the coil with a brush. Use an indoor coil cleaner and water to clean between the fins.
- ✓ Straighten bent fins with a fin comb.

Air-Conditioning Evaporator Coil Temperatures

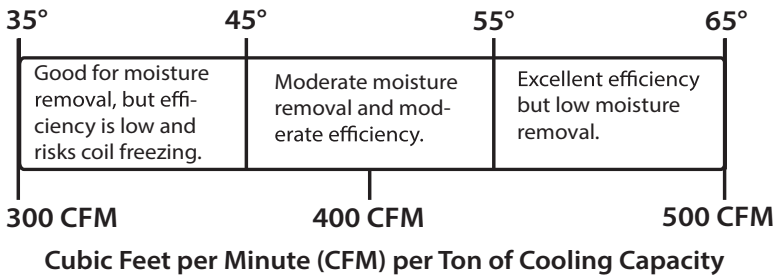

Coil temperature and airflow: The ideal airflow and coil temperature vary by the average relative humidity of a local climate.

8.21.2 Air-Conditioner Sizing

Calculate the correct size of an air conditioner before purchasing or installing it. The number of square feet of floor space that can be cooled by one ton of refrigeration capacity is determined by the home's energy efficiency. Air-conditioners provide cooling most cost-effectively when they are sized accurately and run for long cycles.

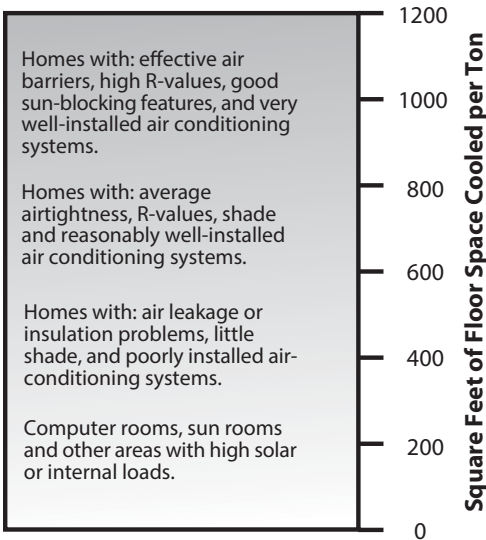

Air-conditioner sizing:
 An energy-efficient home shouldn't need more than a ton of air-conditioner capacity per 1000 square feet of floor area.

The cooling-cost reduction strategy should focus on making the home more energy efficient and making the air conditioner work more efficiently. Making the home more efficient involves shading, insulation, and air-leakage reduction. Making the air conditioner more efficient involves duct sealing, duct insulation, and a quality installation.

8.21.3 Evaluating Air-Conditioner Charge

SWS Detail: 5.01 Forced Air; 5.0102 Condensate Removal; 5.0103 Refrigerant Loop; 5.0103.2 Refrigerant Charge; 5.0103.3 Thermostatic Expansion Valve; 5.0103.4 Compressors

Air-conditioning replacement or service includes refrigerant charge-checking. HVAC technicians evaluate refrigerant charge by two methods depending on what type of restrictor the air conditioner has.

1. If the restrictor has a fixed orifice, the technician performs a superheat test.
2. If the restrictor is a thermostatic expansion valve (TXV), the technician performs a sub cooling test.

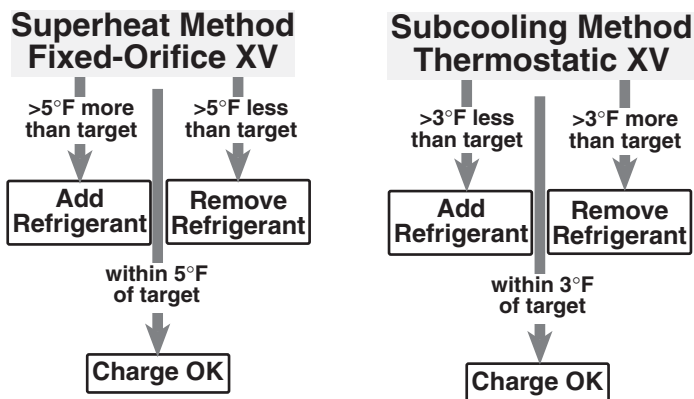

Charge-checking: Two methods help technicians judge whether the charge is correct. The remedy for incorrect charge is to either add or remove refrigerant.

These two tests indicate whether the amount of refrigerant in the system is correct.

Perform charge-checking after the airflow tests, airflow adjustments, and duct-sealing are complete. Do charge-checking during the cooling season while the air conditioner is operating.

CHAPTER 9: VENTILATION

This chapter discusses ventilation, fans, termination fittings, ducts, and passive vents.

This chapter covers these 4 types of ventilation.

1. Local ventilation
2. Whole-dwelling ventilation
3. Attic and crawl space ventilation
4. Ventilation for cooling

9.1 POLLUTANT CONTROL

Controlling pollutants at the source is the highest priority for good indoor air quality. Mechanical ventilation dilutes pollutants. Ventilation is ineffective against prolific sources of moisture and pollutants. Ask these questions to evaluate pollution sources.

- Do the occupants have symptoms of dwelling-related illnesses?
- Do sources of moisture like ground water, humidifiers, water leaks, or unvented space heaters cause indoor high relative humidity or moisture damage?
- Are there combustion appliances in the dwelling?
- Do the occupants smoke?
- Do the occupants use plug-in air fresheners, scented candles or other chemical fragrances?

- Are there paints, cleaners, pesticides, gas or other chemicals stored in the home?
- Deferral must be considered when there are pollutant sources that cannot be controlled.

9.1.1 Pollution-Control Checklist

SWS Details: 6.02 Local Ventilation; 6.02 Whole Building Ventilation

Survey the home for pollutants before air sealing or ventilating the home. Perform the following pollutant control measures.

- ✓ Repair roof and plumbing leaks.
- ✓ Install a ground moisture barrier over bare soil.
- ✓ Verify dryer ducts and exhaust fans exhaust to the outdoors.
- ✓ Verify that combustion appliance vent systems operate properly.
- ✓ Move paints, cleaning solvents, and other chemicals out of the conditioned space.
- ✓ Air seal between attached garages and a dwelling's conditioned areas.
- ✓ Weatherization cannot be performed on a dwelling with an unvented combustion heater as its primary heat source.

The dwelling occupants are often the source of many home pollutants. Educate the residents about minimizing pollutants in their dwelling. [See WPN 17-7](#).

9.2 ASHRAE STANDARD 62.2–2016

VENTILATION

Refer to ASHRAE 62.2-2019 Standard: SWS Details: 6.0201 Local Ventilation; 6.03 Whole Building Ventilation

Many dwellings rely on air leakage for ventilation. The American Society of Heating, Refrigerating, and Air Conditioning Engineers (ASHRAE) publishes ventilation standards for dwellings.

ASHRAE 62.2–2016, defines the roles and **minimum** requirements for mechanical and natural ventilation systems.

9.2.1 ASHRAE 62.2–2016 Components

During weatherization, you may need to install a whole dwelling mechanical ventilation system.

There are 3 types of mechanical ventilation that can be installed to meet the ASHRAE 62.2-2016 Standard. They are as follows:

1. Exhaust ventilation
2. Balanced ventilation
3. Supply ventilation

9.2.2 Whole-Dwelling Ventilation Requirement

SWS Details: 6.03; Refer to ASHRAE 62.2-2016

To comply with ASHRAE 62.2–2016, one can use the formula shown here to determine the whole-dwelling ventilation airflow requirement. Indiana weatherization energy auditors are required to take the ASHRAE 62.2 course at INCAA.

Note: If the ventilation airflow requirement is less than 15 CFM, ASHRAE 62.2–2016 exempts the mechanical ventilation requirement.

Option 1: Finding the Airflow Requirement Using the Formula

If you want to install the minimum ventilation capacity, you can use these 3 steps to follow the formula option.

1. Determine the floor area of the conditioned space of the home in square feet (A_{floor}).
2. Determine the number of bedrooms (N_{br}).
3. Insert these numbers in the formula below.

$$\text{FAN AIRFLOW(CFM)} = 0.03\text{AFLOOR} + 7.5(\text{NBR} + 1)$$

From ASHRAE Standard 62.2-2016

Option 2: Use the ASHRAE 62.2 Ventilation Sizing calculator located at [Intelligentweatherization.org](http://intelligentweatherization.org) (Retro App A) to determine the continuous ventilation CFM requirement.

<http://intelligentweatherization.org/weatherization-forms/>

<http://redcalc.com>

Either form may be utilized, however, the QCI must utilize the same form that the energy auditor utilized.

Refer to the *ASHRAE Standard* for full details.

9.2.3 Local Exhaust Ventilation Requirement

SWS Detail: 6.02 Local Ventilation; 6.0302 Exhaust Ventilation; 6.0302.1 Individual Exhaust Fan Serving Entire Dwelling; 6.0302.2 Multiport Exhaust Fan Serving Multiple Dwellings

There are two options for complying with the local ventilation for kitchens and bathrooms when applicable.

1. For demand-controlled exhaust specify a minimum of 100 CFM for the kitchen and 50 CFM for each bathroom.
2. For continuous exhaust specify a minimum of 20 CFM for each bathroom and 5 ACH for the kitchen (based on volume).

Local Exhaust Deficit

If the existing kitchen or bathroom ventilation does not meet the requirements stated above, you may adjust the whole-dwelling ventilation rate to compensate for the local airflow deficits. Utilize the *Intelligent Weatherization ASHRAE Calculator* or the *RED Calc Free* to determine ventilation needs.

1. Determine the total local exhaust ventilation requirement for all kitchens and bathrooms.
2. Measure the exhaust airflow of existing kitchen and bathroom exhaust fans using flow hood.
3. Enter data into digital ASHRAE calculator to determine ventilation compliance requirement.



Measuring fan airflow: Use an exhaust-fan flow meter or a flow hood to verify the airflows through local exhaust fans and whole-building ventilation fans.

9.2.4 Infiltration Credit

ASHRAE 62.2–2016 allows for infiltration to contribute to the dwelling’s ventilation airflow.

Calculating the infiltration credit without software is complicated. To determine the infiltration credit utilize the [Intelligent Weatherization ASHRAE Calculator](#) or the [RED Calc Free](#) online tool and select “yes” for the “Use the infiltration credit” option.

9.3 FAN AND DUCT SPECIFICATIONS

This section covers fan and duct specifications for both local ventilation and whole-dwelling ventilation. Duct sizing, materials, and installation determine whether airflow meets the design airflow rate (CFM). Many existing ventilation systems do not achieve their design airflow because of installation flaws. Follow all manufacturer's specifications for the installation of mechanical ventilation.

9.3.1 Fan Specifications

SWS Detail: 6.01 Infrastructure; 6.0101 Components; 6.0101.1 Ventilation Ducts; 6.0101.2 Exhaust Terminations; 6.0101.3 Exterior Intakes; 6.0101.4 Fan Controls; 6.0101.5 Airflow Control Devices; 6.0101.6 Variable Frequency Drives and ECMs

We highly recommend continuous ventilation. Continuous ventilation simplifies design and control.

General Fan and Ventilator Specifications

Exhaust fans, installed as part of weatherization work, must vent to outdoors and must meet the ASHRAE Standard and other AHJs.

Table 9-1: Fan Noise Limits ASHRAE 62.2–2016

Fan	Noise Rating (sones)
Whole-dwelling fans	1 sone or less
Local ventilation up to 400 CFM	3 sones or less

Fan Installation

- ✓ Install the fan or ventilation as close as possible to its termination except for in-line fans.
- ✓ Orient the housing so that the exit fittings face toward their termination fittings.
- ✓ Ensure proper operation of the back draft damper.
- ✓ Repair or replace the backdraft damper on an existing fan, if the damper doesn't open and close freely.
- ✓ Install in-line fans and multi-port ventilation in remote areas such as attics and crawl spaces and connect the fans to intake grilles in rooms.
- ✓ Install all ventilation in compliance with ASHRAE standards and manufacturer's specifications.
- ✓ Measure the fan airflow to verify compliance with ASHRAE 62.2–2016.
- ✓ It is not a good idea to install ASHRAE fans with air intake at the floor level.
- ✓ Ventilation must be installed as designed by manufacturer.



Two- or variable-speed fan: An occupancy sensor toggles between speeds. A 6-inch outlet provides airflow for whole-building ventilation.



Advanced 4-speed range fan: Lower speeds for continuous ventilation and higher ones for spot ventilation.



In-line fan in attic: A Y exhausts airflow from two bathrooms for both local exhaust and whole-building ventilation.

9.3.2 Termination Fittings

SWS Detail: 6.0101.2 Terminations

Termination fittings for intake and exhaust ducts must exclude pests and water. Termination fittings must comply with these specifications.

- ✓ The hole in the building shell shall be no greater than 1/4” larger than the size of the hole required to accommodate the termination fitting.
- ✓ Termination fitting must direct water away from its opening.
- ✓ Flash or weather-seal termination fittings.
- ✓ Termination fittings must have insect screens over the openings. Insect screen openings must be between 1/4” and 1/2” in size.
- ✓ The termination-fitting collar must be the same diameter as the exhaust or intake fitting on the fan.



PVC elbow: This screened PVC elbow is an intake fitting for an HRV.

- ✓ If the fan has no backdraft damper and the fan operates intermittently, install a termination fitting with a backdraft damper, to operate in the direction of airflow.
- ✓ Fasteners must not interfere with backdraft-damper operation.

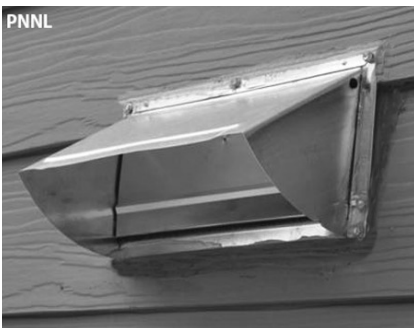

Termination fitting: If the fan operates intermittently, the termination fitting or the fan must have a backdraft damper.

Locating Termination Fittings

Locate termination fittings using these specifications.

- ✓ As directed by manufacturer specifications
- ✓ Must be installed in compliance with **SWS 6.03 - Whole Building Ventilation**
- ✓ Above local snow or flood line
- ✓ As required by local building authority
- ✓ Exhaust terminations must be at least 3 feet away from an operable opening to houses and the property line.

9.3.3 Duct Sizing

Fans often fail to deliver their rated airflow capacity. Bends, un-straight flex duct, dirty grills, and backdraft dampers can reduce design airflow by 50% or more.

If you follow the sizing in this table, you may achieve the fan's rated airflow for short duct runs with a maximum of two elbows.

For more detailed duct-sizing recommendations, see "[ASHRAE 62.2 Duct Sizing](#)".

Table 9-2: Round Duct Diameters (inches) for Desired Airflows

Desired CFM	25	50	75	100	150	200
Rigid	4	5	6	7	8	9
Flex duct	5	6	7	8	9	10
Friction rate = 0.05; maximum equivalent length = 100 feet						

9.3.4 Duct Materials and Installation

SWS Detail: 6.0201 Local Ventilation; 6.03 Whole Building Ventilation

This sections covers SWS requirements and best practices for installing ventilation ducts connected to exhaust fans, ventilators, and air handlers.

Rigid Duct Installation

SWS- 6.0101.1-Ventilation Ducts

Follow manufacturer's installation instructions and SWS guidance, which include, but are not limited to the following:

- ✓ Flame spread no greater than 25
- ✓ Rigid ducts of 28 gauge or thicker
- ✓ Select duct insulation with a flame spread/smoke development index of 25/50 or less when tested according to ASTM E84 or UL 723,
- ✓ Seal seams with UL 181B or 181B-M listed materials (e.g., mastic, tape)
- ✓ Support flexible and duct board ducts every 4' or less using a minimum of 1-1/2" wide material
- ✓ Install support materials in a way that does not crimp ductwork or cause the interior dimensions of the ductwork to be less than specified
- ✓ Support metal ducts every 10' or less using 1/2" or wider material, using 18 gauge or greater strapping or 12 gauge or greater galvanized wire
- ✓ Insulate all ducts installed outside of the thermal boundary to a minimum of R-8
- ✓ Insulate all ductwork exposed to the exterior of the building to a minimum of R-12

9.4 COMMISSIONING VENTILATION SYSTEMS

Commission new, retrofitted and serviced whole-dwelling ventilation systems to verify that the systems function according to design and the ASHRAE 62.2 standard.

- ✓ Verify that all the required ventilation-system components are present and connected correctly.
- ✓ Use airflow and pressure manometers that are appropriate for the operating range.
- ✓ Measure total airflow, room airflows, and total static pressure to verify that these measurements are within design specifications.
- ✓ Adjust fan speed bring airflow into conformance with design specifications.
- ✓ Verify that all sensors and controls function correctly.
- ✓ Provide required compliance documentation with ASHRAE 62.2 2016.

9.5 WHOLE-DWELLING VENTILATION SYSTEMS

This section discusses three options for design of whole-building ventilation systems.

- ✓ Exhaust ventilation
- ✓ Supply ventilation
- ✓ Balanced ventilation

9.5.1 Exhaust Ventilation

SWS Detail: 6.0302 Exhaust Ventilation

Exhaust ventilation systems employ an exhaust fan to remove indoor air, which infiltrating outdoor air then replaces.

Installing a two-speed bathroom fan is a common ventilation strategy. The new fan runs continuously on low speed for whole-building ventilation. A built-in occupancy sensor switches the fan automatically to a high speed to remove moisture from the bathroom quickly.

A remote fan that exhausts air from several rooms through ducts (4-to-6 inch diameter) may provide better ventilation for larger more complex dwellings.

Exhaust ventilation systems create a negative house pressure, drawing outdoor air in through leaks in the shell. This keeps moist indoor air from traveling through building cavities. The negative building pressure reduces the likelihood of moisture accumulation in the building during the winter months in cold climates. In hot and humid climates, however, this depressurization can draw moist outdoor air into the home through building cavities.

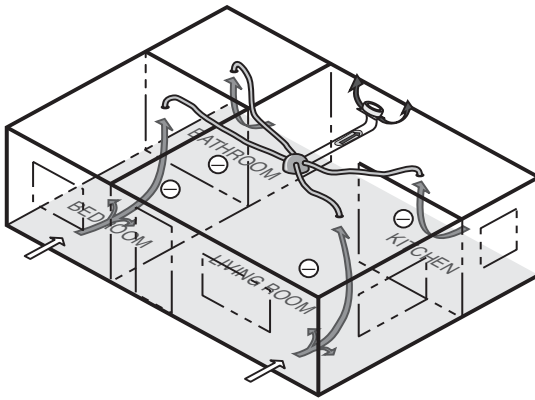

Multi-port exhaust ventilation: A multi-port ventilator creates better fresh-air distribution than a single central exhaust fan.



Passive intake vent: Exhaust ventilation systems often use passive vents to supply make-up air. This vent is close-able for very cold weather

Single-Family Exhaust-Ventilation-System Specifications

- ✓ Exhaust systems must conform to *the ASHRAE 62.2 - 2016 and the SWS Standards for Indiana weatherization.*
- ✓ Use passive intake vents only if you can air seal the building to 1 ACH₅₀ or less. Otherwise the ventilation fans may draw their makeup air from air leaks rather than the passive vents.

Multi-room Exhaust-Ventilation-System Specifications

- ✓ Exhaust systems must conform to the ASHRAE 62.2 - 2016 and the SWS Standards for Indiana weatherization.
- ✓ Evaluate the seal between the roof-mounted ventilator and the its ducts and the roof.
- ✓ Evaluate ventilation-duct chases for air leakage.

- ✓ Install backdraft dampers on intermittently operating systems.
- ✓ Measure airflow through registers to ensure a correct airflow rate.
- ✓ Adjust ventilator airflow if building ventilation airflow is either excessive or insufficient.
- ✓ Insulate ducts outside the thermal boundary to R-8.
- ✓ Fire dampers must be accessible for inspection and testing.
- ✓ Educate occupants or building manager on maintenance procedures.

9.5.2 Supply Ventilation

SWS Detail: 6.0301 Supply Ventilation: 6.0301.1 Fresh Air Intake in Forced Air System; 6.0301.2 Dedicated Air Handler for Multiple

Supply ventilation, using the home's air handler, is never operated continuously as with exhaust ventilation because the furnace or heat-pump blower is too large and would over-ventilate the home and waste electrical energy. Supply ventilation may not be appropriate for tight dwellings in cold climates because supply ventilation can push moist indoor air through exterior walls, where moisture can condense on cold surfaces.

Supply ventilation: A furnace or heat pump with an outside air duct intake is used for ventilation with a control that ensures sufficient ventilation.

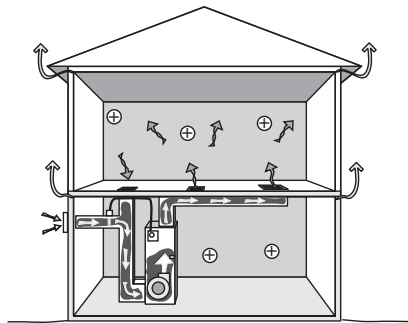

Motorized Outdoor-Air Damper

A motorized damper that opens when the air-handler blower operates must control outdoor-air supply. The furnace/air conditioner heats or cools the outdoor air as necessary before delivering it to the living spaces.

The damper control estimates how much ventilation air is needed. The damper closes after the required amount of ventilation air has entered during heating or cooling. The control also activates the damper and the blower for additional ventilation air as needed without heating or cooling the air during mild weather.

Supply-Ventilation System Requirements

Supply ventilation typically uses the furnace or heat pump as a ventilator. A 5-to-10 inch diameter duct connects the furnace's main return duct to a termination outdoors.

- ✓ The existing duct system must leak less than 10% of the air handler flow when measured at 25 Pa. WRT outside.
- ✓ The outdoor air must flow through a MERV 6 or better air filter before flowing through heating and cooling equipment.
- ✓ Supply systems must conform to the ASHRAE 62.2 - 2016 and the SWS Standards for Indiana weatherization.

9.5.3 Balanced Ventilation

SWS Detail: 6.0303 Balanced Ventilation; 6.0303.1 HRV/ERV Installation

Balanced ventilation systems exhaust stale air and provide fresh air through a ducted distribution system. Of the three ventila-

tion systems discussed here, balanced systems do the best job of controlling pollutants in the home.

Balanced systems move equal amounts of air into and out of the home. Most balanced systems incorporate heat-recovery ventilators or energy-recovery ventilators that reclaim heat and moisture from the exhaust air stream.

Centralized balanced ventilation:

Air is exhausted from areas most likely to contain pollutants and fresh air is supplied to living areas.

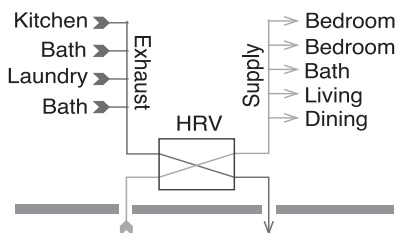

Balanced ventilation systems can improve the air quality and comfort of a home, but they require a high standard of care. Testing and commissioning are vital during both the initial installation and periodic service calls.

Heat-Recovery and Energy-Recovery Ventilators

The difference between heat-recovery ventilators (HRVs) and energy-recovery ventilators (ERVs) is that HRVs transfer heat only, while ERVs transfer both sensible heat and latent heat (moisture) between air streams.

HRVs are often installed as balanced whole-building ventilation systems. The HRV core is an air-to-air heat exchanger in which the supply and exhaust air streams pass one another and exchange heat without mixing.

✓ Balanced systems must conform to ASHRAE 62.2 - 2016 and the SWS Standards for Indiana weatherization.

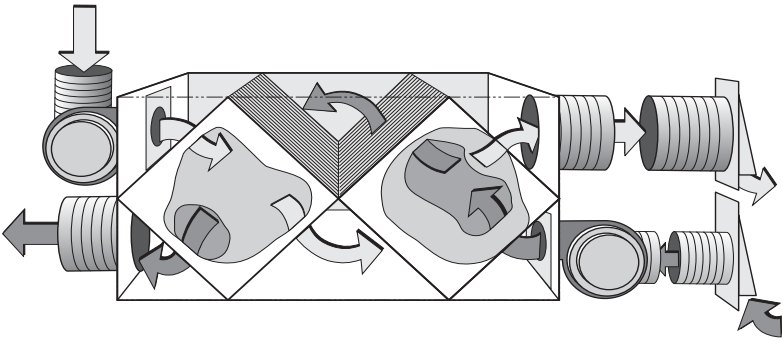

Heat-recovery ventilator: Heat from the exhaust air heats a plastic or aluminum heat exchanger, which in turn heats the fresh intake air. Two matched fans provide balanced ventilation.

9.5.4 Rooftop-Unit (RTUs) Economizer Ventilation

SWS Detail: 6.03 Whole Building Ventilation

Many buildings, particularly those with RTUs use economizers as their ventilation system. Economizers don't normally have heat recovery or energy recovery function, so ventilating with an economizer can have an energy penalty compared to a heat recovery ventilators.

Mild climates are ideal for ventilating with an economizer. When buildings use an economizer for ventilation, its dampers are open a small amount while the HVAC system is heating, cooling, or operating on the fan-only option. The fan-only option is for when you need ventilation but not heating or cooling.

To run optimally, the economizer requires a programmable thermostat that tracks the amount of ventilation air delivered

during the free cooling mode and during the ventilation mode.
See “RTU Maintenance and Improvement”

For information on cooling with an economizer, see
“Economizers”

9.6 GARAGE EXHAUST VENTILATION

SWS Detail: Garage Exhaust Fans

Attached garages, particularly garages beneath living areas, may require exhaust ventilation to prevent indoor CO contamination. Only consider garage exhaust ventilation when all attempts to air-seal the garage from the house have been insufficient.

- Use pressure diagnostics to assist in determining the level of connection from the garage to the house and in making the determination for the need to add garage ventilation.
- Provide requests for garage ventilation to IHCD and they will evaluate the request on a case-by-case basis.
- Garage ventilation systems must comply with the SWS.
- Make sure the fan doesn't cause an unacceptable depressurization in a nearby CAZ. \
- Provide pressure relief if necessary.
- For larger multifamily garages, do thorough air sealing and then provide exhaust ventilation necessary to reduce indoor CO to a negligible level.
- See also "Garages Underneath Living Areas/Tuck Under Garage

9.7 MULTIFAMILY VENTILATION

Exhaust-only ventilation is the most common ventilation strategy for multifamily buildings. Vertical chases surround the ventilation ducts and installers cut holes in the chase for the ventilation registers.

Forced-air HVAC systems also provide ventilation to multifamily buildings. The HVAC system delivers a portion of heated and cooled air as outdoor ventilation air.

See the following sections for more information on multifamily ventilation.

- *“ASHRAE Standard 62.2–2016 Ventilation”*
- *“Whole-Dwelling Ventilation Systems”*
- *“Air Filtration for Indoor Air Quality”*
- *“Rooftop-Unit (RTUs) Economizer Ventilation”*
- *“Air Filtration for Air Handlers”*

Roof-mounted ventilator

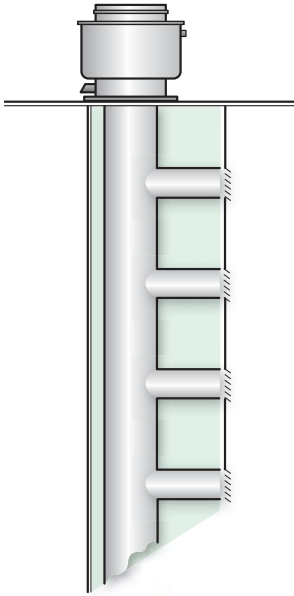

Multifamily exhaust ventilation system: Many multifamily buildings have vertically ducted exhaust ventilation systems with registers opening to kitchens and bathrooms on each floor.

9.8 AIR FILTRATION FOR INDOOR AIR QUALITY

Efficient air filters can reduce particle pollution in homes where particles are an air-quality problem. Ventilation isn't effective at removing small particles. Suggest that clients run their air handlers during heavy air pollution in cities, proximity to dirt roads, seasonal forest fires, and other particle-generating events.

You can run an air-handler fan using the “fan only” setting on a thermostat. You can even program the fan to run for a period each day using a programmable thermostat.

The best places for filters are in forced-air HVAC systems or in balanced ventilation systems. Room air cleaners can also be effective particle removers.

Air filters affect the airflow and energy consumption of forced air HVAC systems and balanced ventilation systems. Before

choosing the type of air filter and deciding to use the filter to remove particles, consider the filter's MERV rating and a home's need for particle removal. For more information on MERV ratings.

9.8.1 Installing Filters for Outdoor Air

Provide filters for outdoor supplied through ducted ventilation systems and observe these specifications.

- ✓ Select a filter with a MERV rating of 6 or greater.
- ✓ The filter's pressure drop must not result in insufficient ventilation airflow.
- ✓ Install the filter on the inlet side of the fan.
- ✓ Make the filter accessible for changing or cleaning.
- ✓ Instruct the occupants or building manager on how and when to service the filter.

9.8.2 Adaptive Ventilation

SWS Detail: 6.0304 Passive Ventilation; 6.0304.1 Multistory Passive Ventilation

The dwelling's residents can maintain good indoor air quality by using spot ventilation together with opening windows and doors. Depending on climate and season, residents can control natural ventilation to provide clean air, comfort, and energy efficiency.

- ✓ Choose windows and screen doors in strategic locations to ventilate using prevailing winds.
- ✓ Make sure that windows and screen doors, chosen for ventilation, open and close and have effective insect screens.

- ✓ Open windows to provide make-up air when an exhaust fan or the clothes dryer is operating.
- ✓ Understand that dust and pollen may enter through windows or screen doors and consider the consequences.

9.9 ATTIC VENTILATION

SWS Detail: 4.0188.2 Attic Ventilation

Attic ventilation has the following functions.

- To keep the attic insulation and the attic's other building materials dry by circulating air.
- To help prevent ice dams in cold weather by preventing snow melt and keeping the roof deck cold during the winter.
- To help remove solar heat from the attic during the summer.

9.9.1 Attic Ventilation as a Solution for Moisture Problems

The best way to keep attic insulation dry is to air-seal the attic floor to block moist indoor air from entering the attic. Adding attic vents may help to solve certain attic moisture problems.

- Seasonal moisture deposition.
- Ice damming in areas that currently lack high and low vents.

Adding attic vents won't solve these attic moisture problems.

- Moisture deposited by air leaks between the living space and the attic.
- Rain driven through attic vents.

- Roof leaks that dampen building materials beyond the capacity of the vents to dry.

9.9.2 When to Install Attic Ventilation

Install more attic ventilation only if you believe that the home needs one of the attic-ventilation functions listed above. Consider the following discussion points.

- Don't increase attic ventilation without first sealing attic air leaks and testing the attic air barrier for adequate airtightness.
- Avoid cutting new vents through the roof to avoid the possibility of roof leaks.
- Attic ventilation may not provide a useful function in some climates, such as persistently damp climates or windy, rainy climates.

Important note: The IRC offers an outright exception to ventilating attics if a code official determines that “atmospheric or climatic conditions” aren't favorable to attic ventilation.

9.9.3 Attic Ventilation Requirements

Always vent exhaust fans directly to outdoors (through a soffit, gable, or wall) and never into a ventilated attic.

Net free area is the area of the vent minus the vent's solid obstructions such as screens and louvers. The net free area is typically 50% to 75% of the gross vent area.

The IRC states these requirements for attic ventilation.

- ✓ Provide a maximum ratio of one square foot of net free vent area to 150 square feet of attic area.
- ✓ The IRC requires only one square foot of net free area per 300 square feet of attic area for cool-climate ceilings, that have an interior vapor barrier, or well distributed ventila-

tion (high and low), or with thorough air-sealing of the ceiling.

- ✓ Vents must have screens, with $\frac{1}{4}$ -to- $\frac{1}{16}$ inch or less opening, to prevent the entry of pests and to reduce the entry of snow and rain.
- ✓ Vertical vents must have louvers to deflect rain.

Soffit chute or baffle: Install a maximum amount of insulation that the baffle allows. The chute prevents wind-washing and conveys the ventilation air over the insulation. The distributed vents ventilate the whole surface of the insulation and cool the whole roof in winter, preventing ice damming.

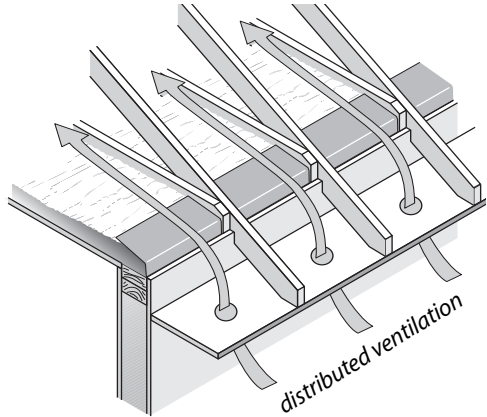

- ✓ Install vent chutes or baffles to prevent blown insulation from entering the space between soffit vents and the attic. The baffles should allow the maximum amount of insulation to be installed over top plates without restricting ventilation paths. Vent chutes or baffles also help prevent the wind-washing of insulation caused by cold or hot air entering soffit vents. T
- ✓ Don't install power ventilators to increase attic ventilation.

High and Low Vents

A combination of high and low vents is the best way to move ventilating air through the attic. Soffit vents and ridge vents are an ideal combination for high-low attic ventilation. However,

gable vents and roof vents, located high or low, also create acceptable ventilation.

Low and high attic ventilation: Distributed ventilation — high and low — is more effective than vents that aren't distributed.

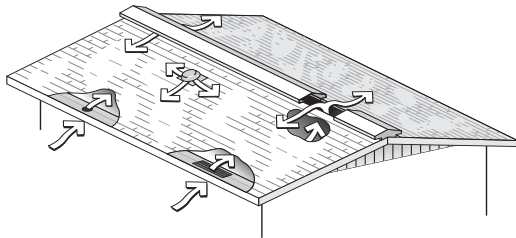

9.9.4 Power Ventilators

Power ventilators have limited value ventilating attics for air-conditioning energy savings or moisture mitigation.

- Power ventilators typically run longer than necessary.
- Power ventilators often consume more electricity than they save in reduced air conditioning.
- Power ventilators can pull conditioned air out through ceiling air leaks, counteracting their ventilating or cooling benefit.
- Existing power attic ventilators will no longer be needed if the attic floor is well sealed and insulation is sufficient. Try to convince the client to allow Wx to disable the fan to save energy.

9.9.5 Unventilated Attics

According to the IRC, new attics may be unventilated if the two conditions listed here are both met.

1. There is no vapor barrier installed in the ceiling.
2. The roof assembly is insulated with an air-impermeable insulation, such as high-density sprayed polyurethane,

to the bottom of the roof sheathing or foam board on the top side of the roof sheathing.

9.10 CRAWL SPACE VENTILATION

Before taking steps to improve crawl-space ventilation, comply with these requirements.

- ✓ The crawl space should have an access hatch or door that is adequate for a worker or resident to enter or exit.
- ✓ Correct grading, drainage, and gutter-and-downspout problems related to crawl-space moisture problems.
- ✓ Install a ground moisture barrier as specified in *“Crawl Space Moisture and Safety Issues”*.
- ✓ Install a sump pump with its discharge drained compliant to code or a French drain to drain.

9.10.1 Naturally Ventilated Crawl Spaces

When insulating the floor, the crawl space is usually ventilated naturally through passive vent openings in the foundation wall. A ground moisture barrier protects the floor insulation and other building materials from moisture. The vent openings can remove small amounts of moisture from the crawl space. Two specifications apply to ventilated crawl spaces.

1. A crawlspace with a ground-moisture barrier may have vent openings equal to 1 square foot of vent area to 300 square feet of crawlspace floor area. A minimum of two vents should be installed on opposite corners of the crawlspace.
2. In a dry crawl space with a ground-moisture barrier, ventilation openings may be minimized to one square foot of net free ventilation area for every 1500 square feet of crawlspace floor area, according to the 2012 IRC.

9.10.2 Conditioned Crawl Spaces

SWS Details: 4.04 Conditioned Subspaces

The IRC requires 1 CFM per 50 square feet of crawl space floor area in conditioned supply air from a forced-air system. The IRC requires openings from the crawl space into the home for this option. The conditioned option requires code-compliant level of foundation insulation appropriate for the home's climate.

9.11 VENTILATION FOR COOLING

Ventilation cooled dwellings for centuries before the invention of air conditioning. Ventilation is still an effective method for clients who can't afford air conditioning. Ventilate with fans during the coolest parts of the day and night, and close the windows during the hottest periods.



Modern whole-house fans:
Modern models feature multiple speeds, tight-sealing insulated enclosures, and quiet operation.



9.11.1 Whole-House Fans

SWS Detail: 3.0103.3 Whole House Fan-Operable

Whole-house fans range in diameter from 24 inches to 42 inches, with capacities ranging from 3,000 to 10,000 cubic feet per minute (cfm). The capacity of the fan in cfm is rated for two different conditions: 1) free air; and 2) air constricted by 1 inch of static pressure. The second condition is closer to the actual operating conditions of the fan in a home, and the cfm rating at 1 inch of static pressure may still be 10 to 30 percent higher than the actual volume of air moved by the installed whole-house fan. This means you should probably install a fan with a greater capacity than the sizing recommendations that follow.

Whole-house fans require 2 to 4 times the normal area of attic vent openings. Install a minimum of 1 square foot of net free area for every 750 cfm of fan capacity. However, more vent area is better for optimal whole-house-fan performance because the extra vent area increases airflow.

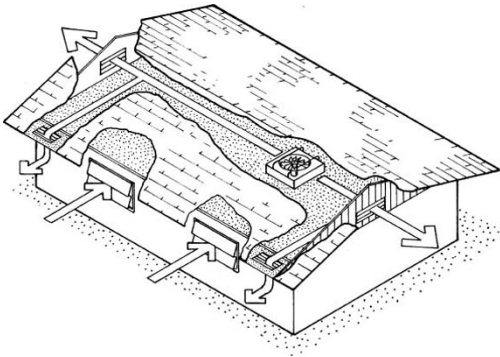

Whole-house fan circulation: the whole-house fan sucks air out of the house and exhausts it into the attic or through a gable wall. Cooler air enters the windows as make-up air for the fan.

To estimate the suitable size of a whole-house fan in cubic feet per minute,

1. First determine the volume of the building in cubic feet. Multiply the square footage of the floor area in your building that you want to cool by the height from floor to ceiling.
2. Take that volume and multiply by 15 to 40 air changes per hour, depending on how much ventilation you want.
3. Then, divide by 60 minutes to get cubic feet per minute of capacity for the whole-house fan.

$$\text{Fan Airflow(CFM)} = \frac{\text{Building volume X 15-40 ACH}}{60}$$

Some fans come with a tight-sealing winter cover. If the fan doesn't have such a cover, or if the attic access doesn't allow you to cover the fan easily, then you can fabricate a cover for the grille on the ceiling. A seasonal cover, held in place with rotating clips or spring clips and sealed with foam tape, works well. If the clients switch between air conditioning and cooling with a whole-house fan as the summer weather changes, build a tightly-sealed, hinged door for the fan opening that is easy to open and close when they switch cooling methods.

Air-sealed and dammed whole-house fan: The whole-house fan must be dammed like an attic access hatch with air sealing and insulation to prevent excessive heat loss or gain.



CHAPTER 10: BASELOAD MEASURES

SWS Detail: Section 7-Baseload

Baseload energy consumption accounts for a large part of home energy use. This chapter discusses energy savings for refrigeration, entertainment, lighting, laundry, and water heating.

Table 10-1: Levels of Household Electric Baseload Consumption

Indicator	Low	Medium	High
kWh per Year	<4500	4500–8500	>8500
kWh per Month	<375	375–700	>700
kWh per Day	<12	12–23	>23
kWh per Person (Annual)	<1900	1900–3500	>3500

Doesn't include heating, cooling, or water heating. Assumes 2.4 persons per household and average annual consumption of 6500 kWh per household.

Baseload Energy Consumption: These baseload usage percents are, of course, different for every dwelling unit. However this chart gives an idea of a typical distribution. Miscellaneous electrical loads or MELs can be up to half of total baseload consumption.

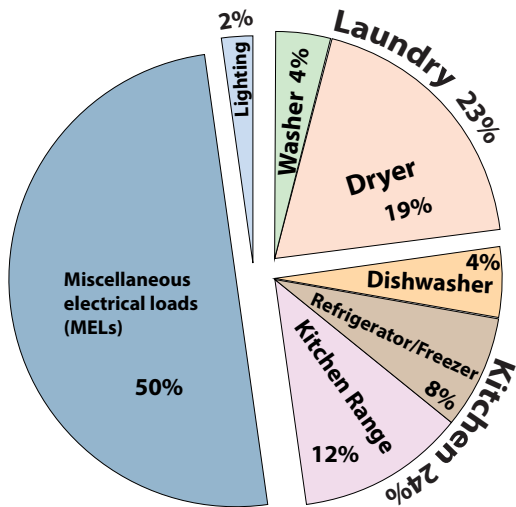

Table 10-2: Electrical Consumption of Typical Appliances

Appliance	Annual usage (kWh)	Annual cost
Ten-year-old refrigerator or freezer	1250	\$150
New ENERGY STAR refrigerator or freezer	500	\$60
Television	100–1000	\$12–\$120
Clothes dryer	1200	\$144
Well pump	500	\$60
Furnace fan	500	\$60
Computer	50–400	\$6–\$48
Hot tub, spa	2300	\$276
Water bed	1000	\$120

Based on Indiana 2020 fuel cost analysis the average cost is 12¢ per kilowatt-hour for electricity.

10.1 REFRIGERATOR REPLACEMENT AND MAINTENANCE

Refrigerators built after 1993 use less electricity than refrigerators built before that year. Another efficiency increase occurred in 1999 in the refrigerator industry.

10.1.1 Refrigerator Replacement

SWS Detail: 7.0101.1 Refrigerator and Freezer Replacement; 7.0101.2 Refrigerator/Freezer Clean and Tune

Refrigerator replacement is an allowable DOE and LIHEAP cost. Indiana requires comprehensive metering of the existing unit and a NEAT/MHEA/Multeia audit must be performed; or using the Koubacavallo database. Comply with the following requirements when replacing refrigerators:

Please see the IHCD Weatherization Policy and Procedure Manual for a comprehensive list of requirements when replacing refrigerators.

Some clients use two or more refrigerators in their homes, and this practice results in high electricity usage. Suggest to these clients to consolidate food storage into a large single refrigerator.

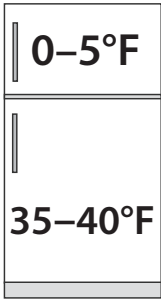

Refrigerator clean and tune: Clean coils and check temperatures. Adjust temperatures that are out of range.



10.1.2 Refrigerator Cleaning and Tuning

SWS Detail: 7.0101.2 Refrigerator/Freezer Clean and Tune

Cleaning and tuning an existing refrigerator can increase its efficiency. Follow these procedures:

- ✓ Clean dirt off clogged coils
- ✓ Move objects that block airflow around the refrigerator
- ✓ Measure refrigerator temperature and verify that it is between 35° and 40° F. Otherwise reset the thermostat to this temperature range
- ✓ Measure the freezer temperature, and verify that it is more than or equal to 0° F. If it is colder than 0°, reset the freezer's thermostat to 0° F
- ✓ Check the condensation-control switch. If the condensation control is on, the refrigerator door or door frame is being heated. Try turning the switch to “energy saver” which turns the heating elements off. If frost forms on the door, turn the control back on
- ✓ Explain the function of the condensation control to clients. If the energy-saver setting isn't adequate for very humid weather, the occupants could toggle setting

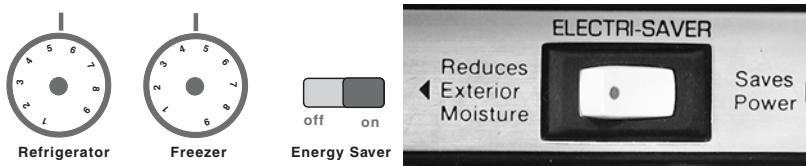

Refrigerator energy controls: Refrigerator and freezer temperatures aren't typically labeled in degrees, so there might be some trial and error in getting the setting within range. The condensation control is either on and heating the door perimeter or off and not heating the door perimeter.

10.1.3 Refrigerator Metering Protocol

You must meter a refrigerator for a minimum of two hours to accurately measure refrigerator energy consumption using a watt-hour meter.

Metering Accuracy Issues

A number of unusual circumstances could reduce the accuracy of the metering, including the following.

- A quantity of warm food recently placed in the refrigerator.
- Abnormally high or low ambient temperature.

Recording watt-hour meter:
Measures energy consumption over time. The better units can also calculate monthly consumption, or record maximum current draw to help identify the defrost cycle.

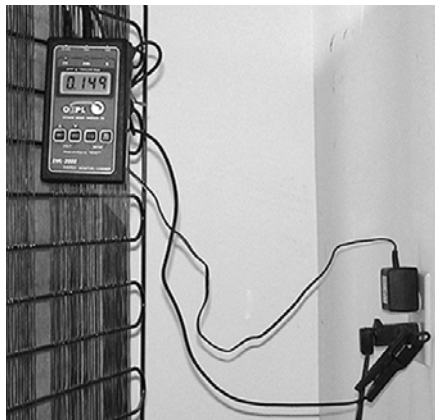

Refrigerator Metering Procedure

1. Connect the refrigerator to a recording watt-hour meter. Run the test for at least two hours. A longer time measurement is more accurate. During the test, avoid opening the refrigerator.
2. At the end of the test, read the kilowatt/hours of consumption measured by the meter. Divide this number by the number of hours in the test. This gives you the number of kilowatt-hours consumed each hour. Multiply this number times the total number of hours in a year (8760 hours per year). The product of this calculation is the annual kilowatt-hours of electrical usage.
3. **Remove the meter and plug the refrigerator back into its outlet.**

$$\begin{array}{ccc} \begin{array}{l} \text{length of test} \\ \text{in hours} \end{array} \swarrow & & \nwarrow \begin{array}{l} \text{number of} \\ \text{hours in a year} \end{array} \\ \mathbf{0.32 \div 2 = 0.16 \times 8760 = 1402} & & \\ \nearrow \begin{array}{l} \text{kilowatt-hours} \\ \text{consumed} \end{array} & \uparrow \begin{array}{l} \text{hourly} \\ \text{consumption} \\ \text{in kilowatt-hours} \end{array} & \nwarrow \begin{array}{l} \text{predicted annual} \\ \text{consumption in} \\ \text{kilowatt-hours} \end{array} \end{array}$$

Refrigerator consumption example: In this example, a 2-hour measurement was performed. During this time, the appliance consumed 0.32 kilowatt-hours of electricity, or 0.16 kilowatt-hours per hour. The annual total of 1402 kilowatt-hours, calculated above, is well beyond the 450 kilowatt-hours per year consumed by today's most efficient refrigerators.

Table 10-3: Kilowatt-Hours per Hour & Kilowatt-Hours per Year

kWh/hour	kWh/year	kWh/hour	kWh/year
0.23	2000	0.16	1400
0.22	1900	0.15	1300
0.21	1800	0.14	1200
0.19	1700	0.13	1100
0.18	1600	0.11	1000
0.17	1500	0.10	900

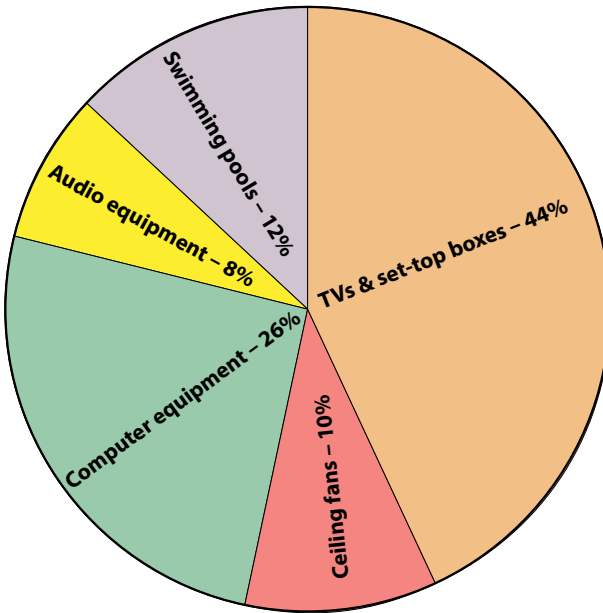

Miscellaneous Electrical Loads (MELs): MELs consume from 1000 to 3000 kWh per household, a huge increase over households 20 or even 10 years ago. The explanation is more TVs with set-top boxes, computers, and electronic entertainment.

10.2 ELECTRONIC ENTERTAINMENT AND COMPUTERS

SWS Detail: 7.1002.1 Consumer Electronics Replacement

The purpose of this section is to help clients conserve electricity and identify major electricity users among their computer and entertainment systems. Use this section as part of your client education.

- ✓ Advise clients to buy equipment labeled ENERGY STAR.
- ✓ Advise clients to buy electronic equipment that doesn't need to be left on when not being used.
- ✓ Recommend power strips be turned off when electronic equipment is not being used or installation of a smart strip
- ✓ Standby losses for electronic equipment should be one watt or less.
- ✓ Read the operating manual and enable all energy-saving features of an appliance. Explain the energy-saving features to the client. Verify that clients have operating instructions for their electronic equipment or that they know how to access instructions using the Internet.
- ✓ Recycle or dispose of equipment using principles of the Environmental Protection Agency (EPA) Responsible Recycling (R2) Initiative.



Smart plug strips: A variety of plug strips with built-in controls are now available. The plug strips interrupts power to appliances by remote control, on a time schedule, or by sensing occupancy.

10.3 LIGHTING-EFFICIENCY IMPROVEMENTS

SWS Detail: 7.0103 Lighting; 7.0104 Lighting Controls

Lighting efficiency improvements include bulb (lamp replacement, daylighting, fixture replacement, and energy efficient lighting controls.

10.3.1 LEDs versus CFLs

Indiana is approved to use LEDs by DOE. CFLs may not be installed.

10.3.2 Light Color

Some clients are sensitive to light color. Manufacturers design and label commercial lamps with a color temperature (°K-Kelvin, depending on their coolness or warmth.

Light color is a complex topic of color measurement by degrees Kelvin (°K through a range of 1000°K (very warm to 10,000°K (very cool. Light bulbs in the 2000-3000°K range are typically best suited for living areas in the home and emit a warm, yellow-white color. Light bulbs in the 3100-4500°K range emit a neutral, white light. This range is best suited to area where bright light is desired. Light bulbs in the 4600-6500°K emit a daylight type of light. These bulbs are a great choice for task lighting and for outdoor security lighting.

10.3.3 Daylighting

SWS Detail: 7.0103,7 Daylighting

Use daylighting as appropriate to save electricity.

- ✓ Educate clients to replace, adjust, or repair window coverings to maximize useful daylight where appropriate.

10.3.4 Home Lighting Retrofit Equipment

SWS Detail: 7.0103.1 Lighting Replacement; 7.0103.3 Ballast Replacement; 7.0103.5 Emergency Lighting Replacement

Consider The following specifications when retrofitting lighting equipment.

- ✓ Ask the client about their lighting usage, and explain the electrical savings potential for switching to LEDs.
- ✓ Select the type of LED and its wattage, according to its use and the client's accustomed light level.
- ✓ Consider the Kelvin temperature of the LED — warm versus cool.
- ✓ Turn on each LED after installation to ensure that it operates. Make sure that the client is satisfied with the light level.



LED recessed-light replacement



LED bulb

LED lamps and fixtures: LEDs now dominate the lighting-retrofit market because of their superior energy efficiency and long life.

- ✓ Replace a halogen-torchiere lamp holder with an LED conversion kit for the torchiere.
- ✓ Replace incandescent bulbs in candelabra fixtures with LEDs designed for this purpose.

- ✓ Install bulbs, fixtures, and controls designed for their intended application (for example: enclosed, dimmable, indoor, outdoor).
- ✓ Select bulbs, fixtures, and controls to provide the brightness and light quality required in that application.
- ✓ All bulbs, fixtures, and controls must be ENERGY STAR® rated where applicable.
- ✓ Bulb wattage must not exceed rated wattage of the light fixture.
- ✓ Select bulb replacements based on expected life span, light quality, and lifetime energy use.
- ✓ Install occupancy sensing controls when appropriate.
- ✓ All bulbs, fixtures, and controls will be UL-approved and installed according to local code(s) and *NFPA 70 National Electric Code*.
- ✓ Upgrading outdoor lights bulbs if they are frequently utilized.
- ✓ Inform clients about recycling of fluorescent bulbs .
- ✓ Replace fluorescent light ballasts containing polychlorinated biphenyls (PCBs) according to the EPA's *Healthy Indoor Environment Protocols for Home Energy Upgrades*.
- ✓ Replace outdoor bulbs that are on a dawn to dusk timer if the bulbs have not been upgraded to LEDs.

10.3.5 Reducing Fixture Wattage in Over-Lit Areas

SWS Detail: 7.0103.2 Lighting Reduction

Many rooms and common areas of multifamily buildings are unnecessarily over lit. Areas that require between 2 and 15 footcandles sometimes measure 20 to 60 footcandles. Measure light levels before and after lighting retrofits.

General Fixture Retrofit

- Clean lenses and fixtures as part of the retrofit.
- Replacing incandescent and CFL bulbs with LEDs.
- Retrofit fixtures in over-lit areas with the same bulb type of a lower wattage and reduced lumen output.
- Replace existing fixtures in intermittently occupied areas with fixtures equipped with integral occupancy sensors if available.



Footcandle meter: Measure light levels in rooms and outdoor areas before and after lighting retrofits.

Multifamily Fluorescent Fixtures

Multifamily stairs, parking garages, hallways, and lobbies are some of the most over lit areas. Fluorescent fixtures light many of these areas. Consider these retrofits depending on the building's budget and the cost of electricity.

- Clean lenses and fixtures as part of the retrofit.
- Replace T-12 lamps with T-8 lamps.
- Remove up to two tubes from 4-lamp fixtures or 1 lamp from a 2-lamp fixtures.
- Modernize existing magnetic-ballast fixtures to the Super T-8 standard.
- Replace fluorescent fixtures with LED fixtures.

Table 10-4: Recommended Horizontal Light Levels (FC)

Building Area	Recommended Footcandles (FC)
Corridors and stairways	5-10
Kitchens and work areas	25-50
Dining rooms and bedrooms	10-20
Common bathrooms	5-10
Parking garages	1-2
Lobbies	5-10
Outdoor walkways	1-2
Outdoor building entrance	2-5



LED candle



LED torchiere

LED lamps: These advanced lamps use about one-third of the electricity of the incandescent lamps they usually replace, and they last about ten times as long.

10.4 CLOTHES DRYERS SERVICE AND VENTING

SWS Detail: 7.0105 Laundry: 7.0105.1 Washing Machines: 7.0105.2 Clothes Dryers

Vinyl flexible dryer vent isn't an approved dryer vent material. To reduce energy cost and improve safety, replace vinyl flex duct with metal dryer vent in compliance with the SWS and manufacturer's requirements.

Service Procedures

As part of the client education process, recommend servicing clothes dryers to prevent fires, reduce drying time, save energy and reduce lint build-up. Service as recommended by the manufacturer.

Dryer Exhaust Venting Requirements

Follow these venting requirements for clothes dryers when servicing dryers.

- ✓ Clean lint from the dryer and vent system when making modifications or improvements to the dryer vent system.
- ✓ Primary dryer duct must have a smooth, metal interior and not be less than 28 gauge.
- ✓ If necessary, the dryer transition ducting material must be UL 2158 A approved and less than 8' in length.
- ✓ Use the shortest practical installation path possible.
- ✓ Don't use screws or rivets to join rigid pipe sections because they collect lint.
- ✓ Exhaust venting duct must be supported at maximum 4-foot intervals.
- ✓ Use short, stretched pieces of flexible metal dryer vent, labeled UL 2158A, to connect the dryer to the rigid vent through difficult framing or to allow dryer to be moved in and out. Make connections using rigid fittings installed male-to-female in the direction of exhaust flow to prevent lint build-up.
- ✓ Fasten UL listed foil-type vent or semi-rigid sheet metal with clamps.
- ✓ Fasten other specialized duct fittings according to manufacturer's specifications.
- ✓ Seal duct connection with foil tape labeled UL 181B or 181B-M.
- ✓ Insulate all dryer vents that run through unconditioned spaces to a minimum R-8.
- ✓ Install a booster fan for dryer ducts exceeding 35 feet in duct equivalent length. When calculating duct length, add 5 feet for each 90° bend and 2.5 feet for each 45° bend, unless otherwise recommended by manufacturer.

- ✓ Dryer terminations will not have a pest screen or other obstruction which could catch lint and hinder air flow.

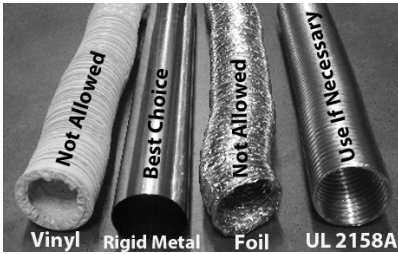

Dryer vent types: Clothes dryer energy-efficiency depends on the type of vent material and the equivalent length of the vent.

10.5 WATER-HEATING ENERGY SAVINGS

SWS Detail: 7.02 Water Heating

For safety information on combustion water heaters.

The most important tasks in evaluating hot water energy savings are determining the water heater’s insulation level, measuring the shower’s flow rate, and measuring the water temperature.

Table 10-5: Water Heating Consumption According to Family Size

Number of Residents	Annual kWh	Annual Therms	Gallons Per Day
1	2700	180	25
2	3500	230	40
3	4900	320	50
4	5400	350	65
5	6300	410	75
6	7000	750	85

Author’s interpretation of data from single-family homes with existing water heaters from Energy Information Administration, Lawrence Berkeley Laboratory, *Home Energy Magazine*, and others.

10.5.1 Water-Saving Shower Heads and Faucet Aerators

SWS Detail:7.02 Water Conservation

Most families use more hot water in the shower than for any other use. A low-flow shower head reduces this consumption.

- ✓ Water-saving shower heads must be rated for a flow of 2.5 gallons per minute or less.
- ✓ Water-saving aerators must be rated for a flow of 2.2 gallons per minute or less.
- ✓ Consider installing a WaterSense rated faucet aerators with a flow rate of 1.5 gpm or less.
- ✓ Consider using a WaterSense rated showerhead with a flow rate of 2.0 gpm or less
- ✓ Measure flow if you are not certain of the flow of an existing fixture. It is not necessary to replace aerators or shower heads that currently meet the standards above.
- ✓ Use caution in removing the existing shower head or aerator from old, fragile plumbing fixtures.
- ✓ The shower or faucet flow rate must be satisfactory to the occupants.
- ✓ Select features that meet any special needs of the occupant: swivel head, hand-held shower.
- ✓ Use a non-hardening thread sealant when installing the device.
- ✓ Check the fixtures after installation for adequate tightness to prevent leakage at the connection.
- ✓ Recycle replaced shower heads and aerators.

Water-saving shower heads: Two styles of water-saving shower heads give consumers a choice between steamy showers and less steamy ones.

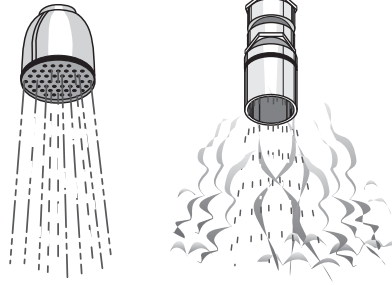

Measuring Shower or Faucet Flow Rate

You can determine flow rate by measuring the time needed to fill a one-gallon plastic container. If the one-gallon container fills in less than 20 seconds, your flow rate is more than 3 gallons per minute.

1. Start the shower and set it to the maximum showering rate.
2. Start a stopwatch at the same time you move the container underneath the shower, capturing its entire flow.
3. Record the number of seconds and divide 60 by that number to find gallons per minute.

Measuring shower flow rate: If you divide 60 by the number of seconds needed to fill a gallon container, you will calculate flow in gallons per minute.

$$\frac{1 \text{ gal}}{15 \text{ sec}} \times \frac{60 \text{ sec}}{1 \text{ min}} = 4 \frac{\text{gal}}{\text{min}}$$

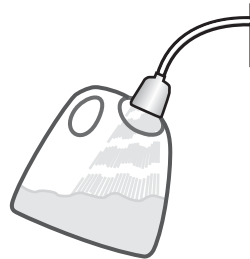

10.5.2 Water Heater Blankets

SWS Detail; 7.0301.2 Tank Insulation

Install a minimum R-10 insulation blanket when cost effective **unless the manufacturer's label prohibits it**. Follow these guidelines to avoid fire hazards and to simplify future service. Water heater insulation must have a flame spread and smoke development index of 25/450 or less when tested in accordance with ASTM E84 or UL723.

Gas Water Heaters

When you install insulation on gas water heaters, use these specifications.

- ✓ Keep insulation at least 2 inches away from the gas valve and the burner access panel. Don't install insulation below the burner access panel.
- ✓ Don't cover the pressure relief valve or discharge line with insulation.
- ✓ Don't insulate the tops of gas-fired water heaters because the insulation can obstruct the draft diverter.
- ✓ Don't insulate Flammable Vapor Ignition Resistant (FVIR) water heaters.

Electric Water Heaters

When you install insulation on electric water heaters, use these specifications.

- ✓ Mark the blanket to locate the thermostat and heating element access plates and cut the blanket at these locations.
- ✓ When you cut the blanket for the thermostats, cut the bottom and sides but not the top. This creates a hinge that allows the door in the insulation to swing open and closed.
- ✓ Cover the top of the water heater with insulation.
- ✓ Don't cover the pressure relief valve and discharge line with insulation.
- ✓ If you specify insulation for an existing water heater which has a relief valve but no discharge line, install a discharge line outside the insulation to within 6 inches of the floor.

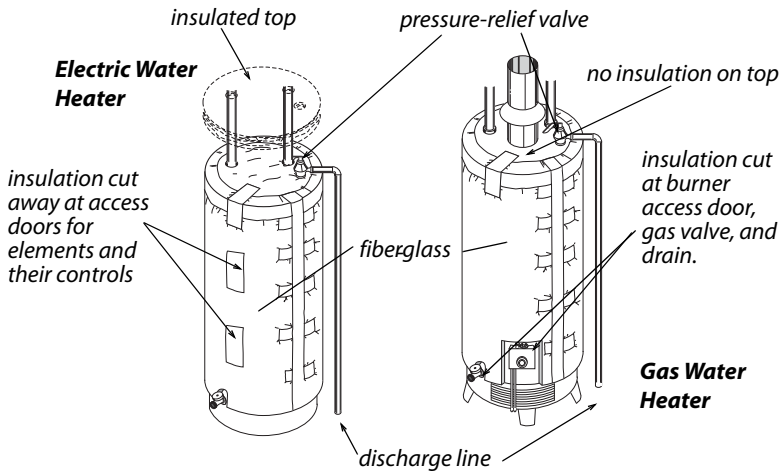

Water heater insulation: Insulation should be installed carefully so it doesn't interfere with the burner, elements, draft diverter, FVIR combustion intake, or pressure relief valve and discharge line.

10.5.3 Measuring and Adjusting Hot Water Temperature

SWS Detail: 7.02 Water Conservation

Use the following instructions to adjust water temperature.

- ✓ Shut off power to an electric water heater before opening thermostat access panels.
- ✓ Measure the water temperature at the nearest faucet to the water heater. Reduce the temperature to no less than 120° F with the client's permission.
- ✓ On electric water heaters, set both upper and lower thermostats to the same temperature.



Setting hot-water temperature: Getting the temperature correct can take a few measurements and re-adjustments.

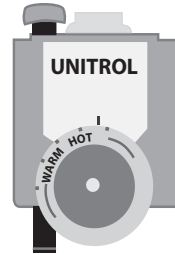

Gas water heater control

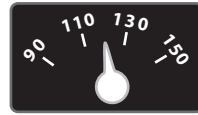

Electric water heater control

10.5.4 Heat Traps and Water-Heater Pipe Insulation

SWS Detail: 7.03 Water Heating: 7.0301.1 Pipe Insulation

Heat traps are piping loops or valves that prevent thermo-siphoning of water in and out of the piping near the water heater. If thermo-siphoning appears to be a problem, install heat traps or some other method to stop hot water from leaving the tank.

Install pipe insulation to slow convection of hot water into the water lines near the tank.

- ✓ Interior diameter of pipe sleeve must match exterior diameter of pipe.
- ✓ Insulate the first 6 feet of hot and cold water pipe from the water heater.
- ✓ Use pipe wrap with a minimum thickness of 1 inch or a minimum R-value of 3. Cover elbows, unions and other fittings with the same insulation thickness as the pipe.

- ✓ Corners must be mitered, tight fitting, sealed and secured with appropriate material to prevent failure.
- ✓ Keep pipe insulation 6 inches away from single-wall vent pipe and 1 inch away from Type B vent.
- ✓ Fasten pipe insulation with zip ties, tape, or other approved method.

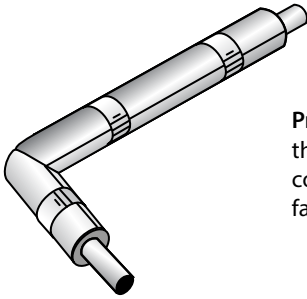

Properly installed pipe insulation: Will be the right size for the pipe, will completely cover the pipe, including bends, and will be fastened tightly to the pipe.

10.6 SELECTING STORAGE WATER HEATERS

SWS Detail: 7.0302 Water Heater Installation

Storage water heaters are the most common water heaters found in homes.

10.6.1 Determining a Storage Water Heater's Insulation Level

Common storage water heaters consist of a tank, insulation surrounding the tank, and an outer shell. There is typically either 1 or 2 inches of insulation surrounding the tank. The insulation is either fiberglass or polyisocyanurate.

Follow this procedure to determine the water heater's insulation level.

- ✓ Look for a listing of R-value on a label on the water heater.

- ✓ Find a hole in the outer shell where the flue pipe emerges or where plumbing connects. Look around the hole for either fiberglass or polyisocyanurate insulation.
- ✓ If the hole isn't large enough to see the insulation level on an electric water heater, try removing the access panel for the heating element after disconnecting power from the unit.
- ✓ You may just be able to see the gap between the tank and outer shell. If you can't see this gap, use a ruler or probe to push through the insulation along side of a pipe connecting to the tank until the probe hits the steel tank to determine thickness. Make sure that the probe is against the tank and not against a nut welded to the tank.
- ✓ If additional tank insulation is installed, it must be at least R-10. **Don't install insulation if the manufacturer's label on the water heater prohibits it.**

Identifying Tank Insulation

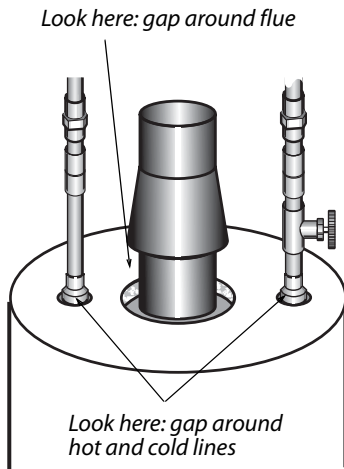

Table 10-6: Insulation R-Values

Insulation/thickness	R
Fiberglass 1 inch	3
Fiberglass 2 inches	6
PIC1 inch	6.5
PIC 2 inches	13
PIC 3 inches	19.5

10.6.2 Storage Water-Heater Selection

Existing gas water heaters, including propane, typically use 200 to 400 therms per year. New gas water heaters use as little as 175 therms per year, resulting in a savings of between 25 and 225 therms per year. Similar savings are possible by replacing electric water heaters. Consider the following recommendations for specifying water heaters.

- A replacement gas or oil storage water heater must be Energy Star rated and be insulated with at least 2 inches of foam insulation.
- A replacement electric water heater should have an energy factor of at least 0.93 and be insulated with at least 2.5 inches of foam insulation.

10.7 ALTERNATIVE WATER-HEATERS

Weatherization programs sometimes choose alternative water-heating products to improve efficiency and safety.

10.7.1 Sidewall-Vented Gas Storage Water Heaters

When gas storage water heaters cause persistent venting problems, specify a sidewall-venting water heater. Two common types of these water heaters are shown here.

- ✓ Choose a sealed-combustion sidewall-vented gas water heater, if possible. Next best is a fan-assisted unit.

- ✓ Install the replacement water heater in accordance with manufacturer specifications and IRC.

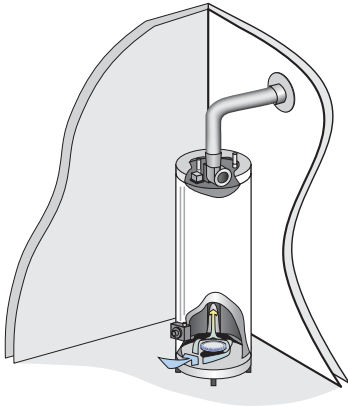

Fan-assisted water heater: The fan allows horizontal venting. The water heater may be open combustion or sealed combustion.

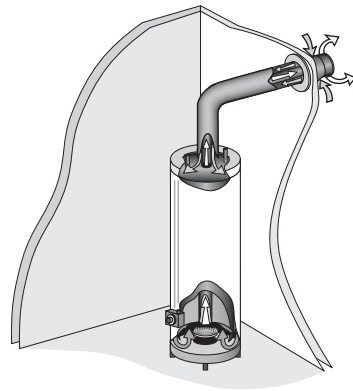

Direct-vent water heater: Moves combustion air and flue gases through a concentric pipe system without a draft fan.

10.7.2 On-Demand Gas Water Heaters

SWS Detail: 7.0302.5 Tankless On-Demand/Point of Use Appliances

On-demand gas water heaters are more efficient and cost less to operate compared to conventional gas storage water heaters. However, on-demand gas water heaters are more expensive to install and may have shorter lifespans compared to storage water heaters.

Choose a sealed combustion on-demand gas water heater, if possible. A fan-assisted on-demand gas water heater is the next best choice.

10.7.3 Heat Pump Water Heaters

SWS Detail: 7.0302.3 Heat Pump Storage Water Heater

Heat pump water heaters can heat water at up to 2.3 times more efficiently than electric-resistance storage water heaters. Heat pump water heaters use heat from surrounding air to heat water. They cost more than conventional electric water heaters but are less costly to operate.



Heat pump water heater: This heat pump water heater has the heating coil (condenser) surrounded by the domestic water.

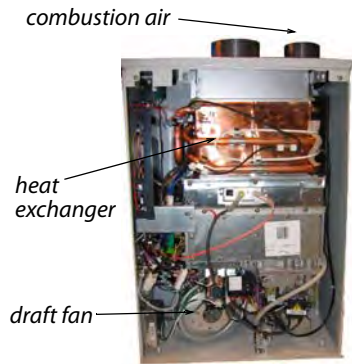

Sealed-combustion tankless water heater: These expensive water heaters have a tiny market share and save around one-third of energy used by the best storage water heaters.

Table 10-7: Comparison of Advanced Water Heaters

Advanced Water Heater Type	\$ Savings*	Expected Lifespan	Major Advantages
High-efficiency storage tank (Oil, gas, electric)	≤\$500	8–15 years	Lowest first cost
Instantaneous Tankless (direct fired)	≤\$1800	5-15 years	Unlimited hot water
Heat pump	≤\$3000	5-15 years	Most efficient electric option
From information supplied by ENERGYSTAR.gov by the Environmental Protection Agency. * Lifetime savings compared to conventional water-heater models and same fuel.			

10.8 WATER HEATER INSTALLATION

SWS Detail: 7.0302 Water Heater Installation

Follow these procedures when installing a storage water heater or an alternative water heater.

- ✓ Replacement water heater must have a pressure-and-temperature relief valve with a discharge line that terminates less than 6 inches from the floor into a floor drain or drain pan.
- ✓ The discharge pipe should be made of rigid metal pipe or approved high-temperature plastic pipe.
- ✓ Install dielectric unions as required.
- ✓ Install an expansion tank for storage water-heater replacements when needed.

- ✓ If leakage would cause damage to the home, install an emergency drain pan.
- ✓ Install a $\frac{3}{4}$ -inch drain line to the tapping on drain pan. Terminate the drain line in a floor drain or outdoors, at least 6 inches above grade.
- ✓ Install heat traps on the water heater's inlet and outlet piping if the manufacturer hasn't provided traps.
- ✓ Adjust water temperature to 120° F.

10.9 COMPARING WATER HEATERS

Fuel switching requires prior approval from the Grantee. Refer to IHCD Policy and Procedures Manual and WPN 19-4 for complete guidance/requirements on fuel switching proposals.

10.9.1 Safety Comparison

Conventional direct-fired gas water heaters vent their combustion by-products to a gravity vented chimney. They can spill products of combustion into the living space. Sharing of a main chimney with another combustion appliance can cause venting problems. If the furnace or boiler is replaced with a sealed-combustion or horizontal-vented model, the chimney may then be too big for the remaining combustion water heater.

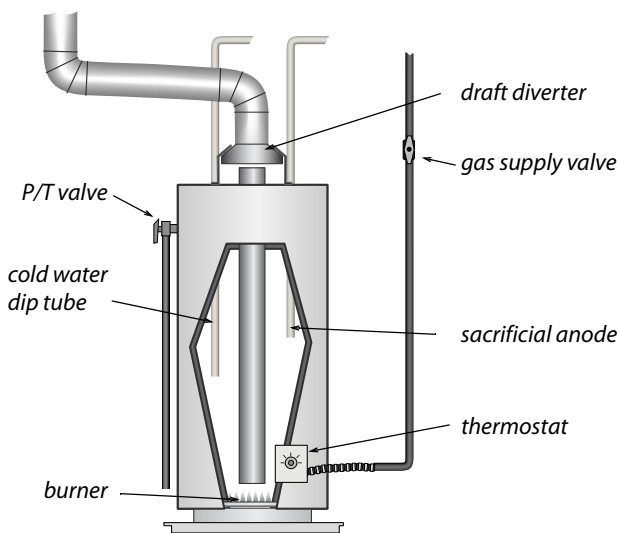

Standard gas water heater: These open combustion appliances are often troubled by spillage and backdrafting.

Electric water heaters have no chimney and need no combustion air.

10.9.2 Reliability Comparison

Storage water heaters are popular because they are inexpensive and reliable. The lifespan of storage water heaters depends on local water quality and the quality of the water heater's storage tank.

10.9.3 Efficiency and Energy Cost Comparison

Conventional gas storage water heaters are rated at about 80% steady-state efficiency. Whenever a storage water heater isn't firing, it's losing heat up the chimney. This off-cycle heat loss reduces annual efficiency. The exact EF for a particular storage water heater is difficult to estimate because of many factors including: chimney height, chimney diameter, wind, the home's air-tightness, outdoor temperature, and water heater temperature set point. Gas storage water heaters cost less to operate than electric water heaters with the same insulation level.

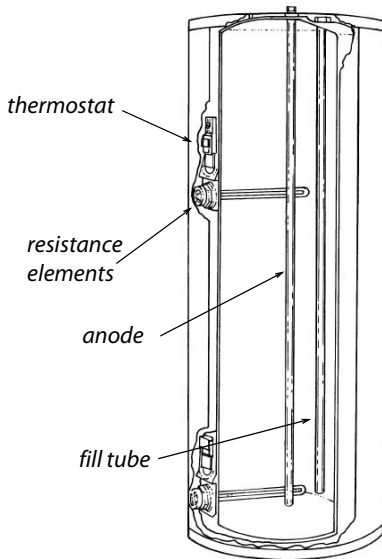

Standard electric storage water heater: Electric water heating is more expensive than gas or oil but safer. Electric water heaters should have at least 2 inches of foam insulation.

As a heating fuel, electricity is more expensive than natural gas. Electric water heaters no chimney losses. Electric water heaters do lose heat through the insulation jacket. Heat-pump water heaters have an operating efficiency of over 200% (COP = 2.3) because they heat water with heat from the surrounding air.

CHAPTER 11: MOBILE HOMES

Manufactured/mobile homes are covered by their own details and outcomes in the SWS. In this chapter, we cover manufactured home air sealing, insulation, windows, doors, and heating systems.

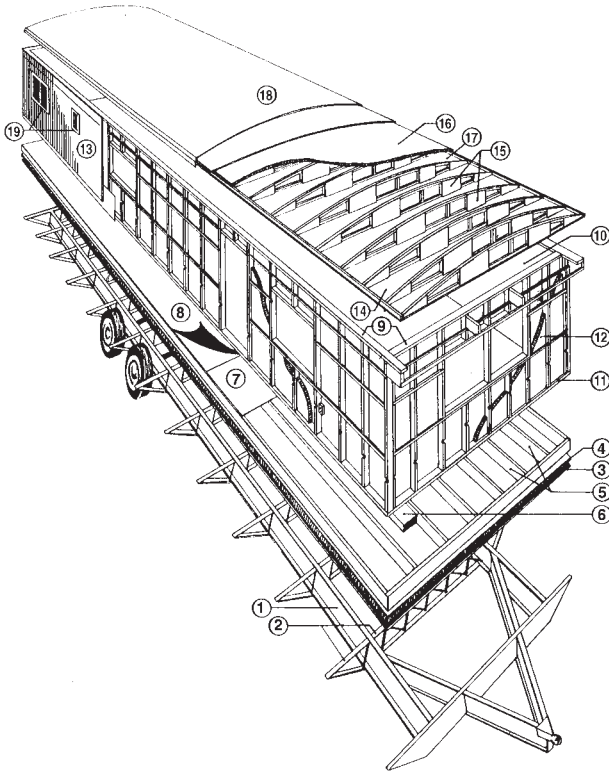

Typical components of a manufactured home: 1–Steel chassis. 2–Steel outriggers and cross members. 3–Underbelly. 4–Fiberglass insulation. 5–Floor joists. 6–Heating/air conditioning duct. 7–Decking. 8–Floor covering. 9–Top plate. 10–Interior paneling. 11–Bottom plate. 12–Fiberglass insulation. 13–Metal siding. 14–Ceiling board. 15–BOWSTRING trusses. 16–Fiberglass insulation. 17–Vapor barrier. 18–Galvanized steel one-piece roof. 19–Metal windows.

11.1 MOBILE HOME HEATING

Mobile home combustion furnaces have been sealed-combustion since the early 1970s. Gas furnaces are either the atmospheric sealed-combustion type or the newer fan-assisted mid-efficiency type. Some older less efficient sealed-combustion furnaces have draft fans. For information on electric furnaces, see *“Electric-furnaces and electric baseboard heat”*

Mobile-home oil furnaces are a close relative to oil furnaces in site-built homes. They should have a housing that fits around the burner’s air shutter and provide outdoor air directly to the burner. See *“Oil-burner safety and efficiency”* and *“Direct combustion air supply to oil-fired heaters”*

Mobile-home furnaces are different from conventional furnaces in the following ways.

- Most are equipped with down flow furnaces, designed specifically for mobile homes.
- Mobile home combustion furnaces are sealed-combustion units that use outdoor combustion air. They don’t have draft diverters or barometric draft controls.
- Gas-fired furnaces have kits attached containing alternative orifices to burn either propane or gas.
- Return air enters the furnace through a large opening in the furnace rather than through return ducts.

Important Note: Install only furnaces—**designed for mobile homes**—in mobile homes.

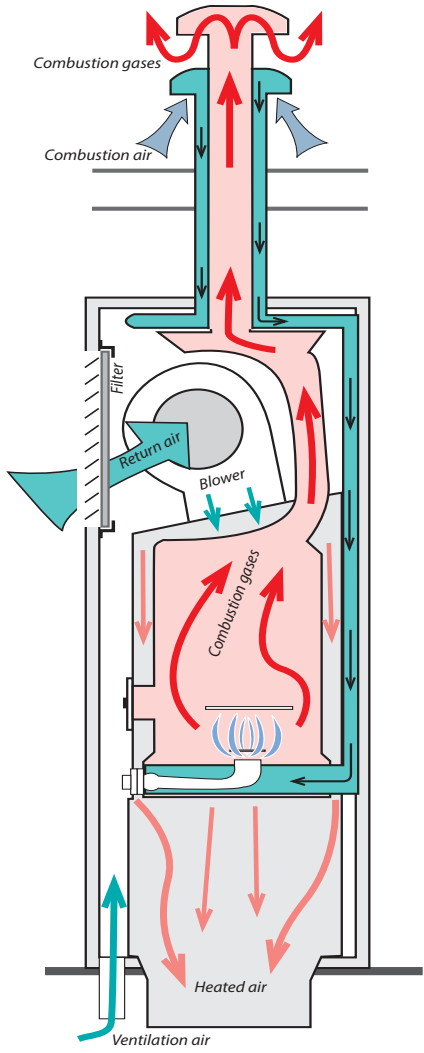

Mobile home furnace airflow: Return air flows from the hallway through the furnace grill. The air is heated and distributed through the ducts.

Mobile home furnace combustion: Combustion air enters through the flue assembly on the roof and feeds the flame through a sealed passageway.

11.1.1 Furnace Maintenance and Energy Efficiency

Mobile home furnaces should comply with this guidebook's combustion safety and efficiency standards. See "[Gas burner safety and efficiency testing](#)" and "[Oil-burner safety and efficiency](#)"

11.1.2 Furnace Replacement

Mobile home furnaces must be replaced with furnaces designed and listed for use in mobile homes.

Consider replacing the existing furnace with a high efficiency furnace.

Replace or repair a mobile home furnace when you observe any of the following.

- The furnace has a cracked heat exchanger.
- Repair and retrofit exceed half of the replacement cost.
- The furnace is not operating and not repairable.
- Existing furnace is not approved for manufactured homes.

Mobile home furnaces require outdoor combustion air. Mobile home furnaces have a manufactured chimney that includes a passageway for combustion air or a combustion air chute connecting the burner with the crawl space.

- ✓ Install a new furnace base unless you are sure that the existing base matches the new furnace.
- ✓ Attach the furnace base firmly to the duct and seal all seams between the base and duct with manufacturer approved sealant.
- ✓ Support the main duct underneath the furnace with additional strapping if necessary.

- ✓ Install a new chimney that is manufactured specifically for the new furnace or install the vent system per manufacturer's instructions.
- ✓ Often the old chimney opening doesn't exactly line up with the new furnace's flue. In these cases either use an off-set pipe, provided by the manufacturer or cut the opening larger so that the new chimney can be installed.

11.2 MOBILE HOME COOLING SYSTEMS

SWS Detail: 5.01 Forced Air

11.2.1 Air-Conditioning Systems

Mobile home central air-conditioning (A/C systems are very similar to those of single-family homes. Mobile home split-system central A/C systems have the condenser and compressor outdoors and the air handler indoors. Packaged A/C systems have all the components in one cabinet.

Consult the following field guide topics as necessary.

- **“Central A/C-Heat Pump Inspection and Maintenance”**
- **“Air-Conditioner Sizing”**
- **“Duct Leakage and System Airflow”**
- **“Evaluating Air-Conditioner Charge”**

11.2.2 Mobile Home Ventilation Systems

SWS Detail: 6.01 Infrastructure; 6.02 Local Ventilation; 6.03 Whole Building Ventilation

Consult the SWS or information on mobile home ventilation systems.

- “Whole-Dwelling Ventilation Requirement”
- “Exhaust Ventilation”
- “Adaptive Ventilation”

11.3 MOBILE HOME AIR SEALING

SWS Detail: 2.02 Moisture; 3.01 General Airsealing

A duct blower, which pressurizes the ducts and measures their air leakage, is the best way to measure and evaluate duct air sealing; however a duct blower does not tell you where the leaks are. It only provides a total cfm measurement of leakage. For locating duct leaks, the blower door used in conjunction with a pressure pan. See *“Pressure Pan Testing”*. Most mobile home duct sealing is performed at the registers, although there are areas that can only be accessed through the belly. Duct repairs should be made prior to patching and insulating the belly. The *desired* goal for ducts are pressure pan readings of 1 or less.

Air Sealing Procedure

Table 11-1: Air Leakage Locations & Typical CFM₅₀ Reduction
Patching large air leaks in the floor, walls and ceiling 200–900

Sealing floor cavity used as return-air plenum (See <i>“Floor return air”</i> on page 478.)	300–900
Sealing leaky water-heater closet	200–600
Sealing leaky supply ducts	100–500
Installing tight interior storm windows	100–250
Caulking and weatherstripping	50–150

Mobile home shell air leakage is often reduced when insulation combined with air-sealing is installed in roofs, walls, and belly cavities. Prioritize your efforts by performing these tasks.

1. Evaluate the insulation levels. If adding insulation is cost-effective, perform air sealing measures.
2. Seal the ducts.

3. Re-check the air leakage with blower door.
4. Perform additional air sealing as needed.

11.3.1 Shell Air Leakage Locations

SWS Detail: 3.01 General Pressure Boundary

Blower doors have pointed out the following shell locations as air leakage sites.

- ✓ Plumbing penetrations in floors, walls, and ceilings.
- ✓ Water heater closets with exterior access.
- ✓ Torn or missing underbelly.
- ✓ Gaps around furnace and water heater vents.
- ✓ Deteriorated floors in water heater compartments
- ✓ Gaps around the electrical panel box, light fixtures, and fans.
- ✓ Holes in interior/exterior sheeting materials.
- ✓ Joints between the halves of double-wide mobile homes and between the main dwelling and additions

11.3.2 Duct Leak Locations

SWS Detail: 3.01 General Pressure Boundary: 5.0105 Duct Repair; 5.0106 Duct Sealing

Blower doors, pressure pan and duct blowers have pointed out the following duct locations as the energy loss problems.

- ✓ Floor cavities used as return-air plenums — These floor return systems should be eliminated and replaced with

return-air through the hall or a large grille in the furnace-closet door.

- ✓ Joints between the furnace and the main duct — The main duct may need to be cut open from underneath to access and seal these leaks between the furnace, duct connector, and main duct. With electric furnaces you can access the duct connector by removing the resistance elements. For furnaces with empty A-coil compartments, you can simply remove the access panel to seal the duct connector.
- ✓ Joints between the main duct and the short duct sections joining the main duct to a floor register
- ✓ Joints between register boots and floor
- ✓ The poorly sealed ends of the duct trunk, which often extend beyond the last supply register
- ✓ Disconnected, damaged or poorly joined crossover ducts
- ✓ Supply and return ducts for outdoor air conditioner units
- ✓ Holes cut in floors.
- ✓ New ductwork added to supply heat to room additions

Seal floor penetrations and ductwork before performing belly repair. Pollutants in the crawl space such as mold and dust will be disturbed by repair work and can be drawn into the home by duct depressurization. *See “Pressure Pan Testing”, “Sealing Supply Ducts”*

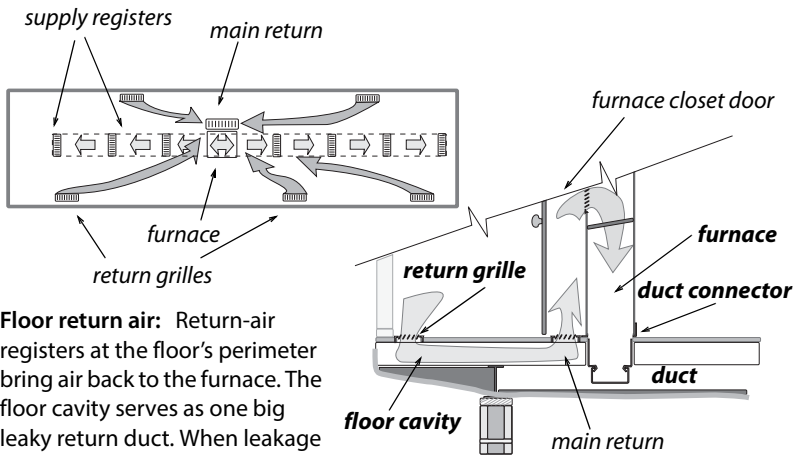

Floor return air: Return-air registers at the floor's perimeter bring air back to the furnace. The floor cavity serves as one big leaky return duct. When leakage is serious, the floor return system should be eliminated.

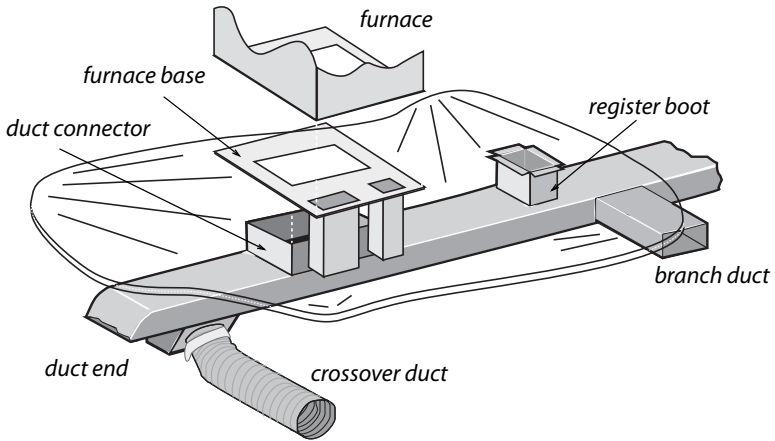

Mobile home ducts: Mobile home ducts leak at their ends and joints — especially at the joints beneath the furnace. The furnace base attaches the furnace to the duct connector. Leaks occur where the duct connector meets the main duct and where it meets the furnace. Branch ducts are rare, but easy to find, because their supply register is not in line with the others. Crossover ducts are found only in double-wide and triple-wide homes.

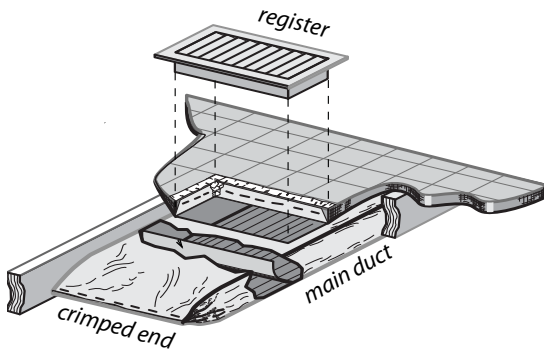

Sealing the end of the main duct: The main duct is usually capped or crimped loosely at each end, creating a major air leakage point. Seal this area by accessing the last register from inside the duct. Seal with approved materials.

11.4 MOBILE HOME INSULATION

Address all significant moisture problems before insulating.

11.4.1 Insulating Mobile Home Roof Cavities

SWS Details: 4.01 Attics; 4.0102.3 Inaccessible Ceiling

Blowing a closed mobile home roof cavity is similar to blowing a closed wall cavity except the insulation doesn't have to be as dense. Use fiberglass blowing wool because cellulose is too heavy and can absorb water.

If existing insulation is attached to the underside of the roof, blow the insulation below it. If existing insulation lays on the ceiling, blow the insulation above it. If you find insulation at both the ceiling and roof, blow the new insulation in between the two existing layers of insulation.

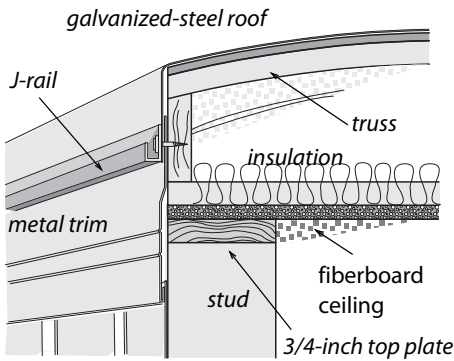

Bowstring roof details:

Hundreds of thousands of older mobile homes were constructed with these general construction details.

There are three common and effective methods for blowing mobile home roof cavities.

1. Cutting a hole in the metal roof and blowing fiberglass through a flexible fill-tube.
2. Blowing fiberglass through holes drilled in the ceiling.
3. Tube filling from the gable ends of the mobile home.

Preparing to Blow a Mobile Home Roof

Perform these steps before insulating mobile home roofs.

- ✓ Reinforce weak areas in the ceiling.
- ✓ Seal all penetrations.
- ✓ Broken mushroom vents will be replaced or removed and sealed.
- ✓ Maintain safe clearances to combustibles.
- ✓ Verify that gas, water, and electrical lines are secured at least every 4 feet to a floor joist or framing member.

Blowing Through the Top

Blowing through the roof top does a good job of filling the critical edge area with insulation. Patches are easy to install.

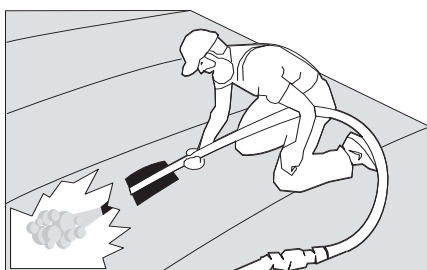

Roof-top insulation: Blowing fiberglass insulation through the roof top is effective at achieving good coverage and density on almost any metal roof. Use walk boards to avoid damaging the roof.

If the roof contains a strongback running the length of the roof, the holes should be centered over the strongback, which is usually near the center of the roof's width. A strongback is a 1-by-4 or a 1-by-6, installed at a right angle to the trusses near their center point, that adds strength to the roof structure.

1. Cut holes to an adequate size for installing insulation. Consider cutting holes above roof framing on bow string construction to allow access to multiple cavities reducing roof patching.
2. Use a 2-inch or 2- $\frac{1}{2}$ -inch diameter fill-tube. Insert the fill-tube and push it out toward the edge of the cavity to ensure complete coverage.
3. Blow fiberglass insulation into each cavity.
4. Fill the area under each square hole with a piece of unfaced fiberglass batt.
5. Patch the hole with a galvanized metal patch 2" larger than the original hole in all directions and sealed with an appropriate sealant and screwed into the existing metal roof. Do not to fasten the patch to any roof framing.
6. Cover the first patch with a second patch, consisting of an 18-inch-square piece of foil-faced butyl rubber. Roll

the adhesive patch with a roofing roller to ensure adhesion.

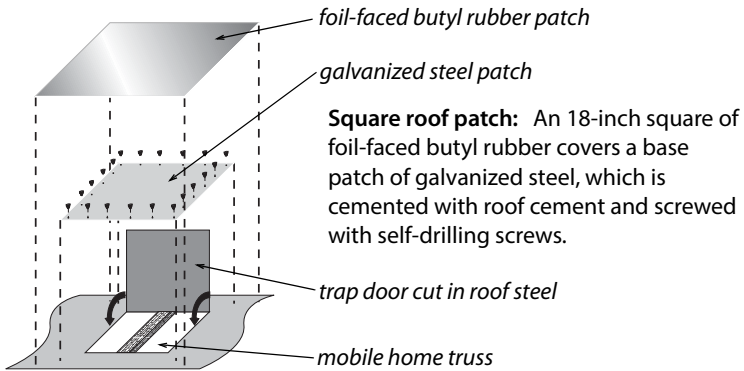

Blowing Through a Round Hole on the Roof

Consider this alternative to cutting a square hole as suggested above.

1. Drill a 3-inch or larger hole between each truss.
2. Use a 2-inch or 2- $\frac{1}{2}$ -inch diameter fill-tube. Insert the fill-tube, and push it out toward the edge of the cavity.
3. Blow fiberglass insulation into each cavity to fill the entire cavity.
4. Patch the holes with galvanized steel, plastic caps, and roofing material compatible with the existing roof.

Blowing a mobile home roof from the gable end

When a mobile home has a truss framed roof system, tube filling the attic from the gable end may be an option. This method requires access through the entire attic system so mobile homes with bow string construction are not a candidate for this option.

As this is a blind blow method, care must be taken if there are furnace vent pipes or non IC rated light fixtures in the attic area. These items will need to maintain clearance to combustibles.

Access the gable end of the mobile home by cutting through the exterior siding. Making the access hole the size of a gable end vent is advisable. If there is a strong back running down the center of the mobile home, then an access hole will need to be cut on each side of the strong back. As most mobile homes are between 50' and 70' long this insulation process will be performed at each end of the home.

Electrical conduit or muffler pipe are two tubing options for blowing the insulation. These types of pipe have bell ends which allow multiple section to be connected together. This segmented install is helpful both for transporting the pipe and for allowing 30+ feet of pipe to be slid into the attic.

- Cut an appropriate size hole in gable end – using an 8x8 or 8x10 gable end vent is adequate.
- Insert the tubing sections into the attic .
- Using two installers makes this process easier.
- One installer will feed the tubing into the attic while the other holds up the other end allowing the sections to be fastened together.
- Using a 45 degree fitting on the end of the tubing allows it to slide in over the ceiling joist much like a sled runner.
- Care should be taken with the density of the insulation depending on the integrity of the mobile home ceiling.
- Allowing the insulation machine to push the tubing out of the attic as it fills will generally yield a good density without over filling the cavity.
- Once the attic has been filled use a section of batt insulation at the access hole to prevent the blown fiberglass from falling from the hole.

- Install the correct sized gable end vent into the access hole and screw and caulk in place.

Blowing a Mobile Home Roof from Indoors

The advantage to this method is that you are indoors, out of the weather. The disadvantages include being indoors where you can make a mess or damage something.

Blowing the roof cavity from indoors requires the drilling of straight rows of 3-inch or 4-inch holes and blowing insulation into the roof cavity through a fill tube.

Follow this procedure.

1. Drill a 3-inch or 4-inch hole in an unseen location to discover whether the roof structure contains a strongback that would prevent blowing the roof cavity from a single row of holes.
2. Devise a way to drill a straight row of holes down the center of the ceiling. If a strongback exists, drill two rows of holes at the quarter points of the width of the ceiling.
3. Insert a flexible plastic fill tube into the cavity, and push it as far as possible toward the edge of the roof.
4. Fill the cavity with tightly packed fiberglass insulation.
5. Patch/cover the holes in compliance with SWS.



Blowing through the ceiling: The contractor pushes the fill-tube into the cavity and out near the edge of the roof. The holes are drilled in a straight line for appearance sake.

11.4.2 Mobile Home Sidewall Insulation

SWS Details: 4.02 Walls

The sidewalls of many mobile homes are not completely filled with insulation. Only install additional wall insulation when cost effective. Consider the following steps for adding insulation to partially filled mobile home walls.

1. Check the interior paneling and trim to make sure they are securely fastened to the wall. Repair holes in interior paneling and caulk cracks at seams to prevent indoor air from entering the wall. Note the location of electrical boxes and wire to avoid hitting them when you push the fill tube up the wall.
2. Remove the bottom horizontal row of screws from the exterior siding. If the vertical joints in the siding inter-

lock, fasten the bottom of the joints together with $1/2$ -inch sheet metal screws to prevent the joints from coming apart. Pull the siding and existing insulation away from the studs, and insert the fill tube into the cavity with the point of its tip against the interior paneling.

3. Push the fill tube up into the wall cavity until it hits the top plate of the wall. The tube should go in to the wall cavity 7-to-8 feet. It is important to insert the tube so that its natural curvature presses its tip against the interior paneling. When the tip of the fill tube, cut at an angle, is pressed against the smooth paneling, it is least likely to snag the existing insulation on its way up the wall. If the fill tube hits a belt rail or other obstruction, twisting the tube will help its tip get past the obstruction.
4. Stuff a piece of fiberglass batt into the bottom of the wall cavity around the tube to prevent insulation from blowing out of the wall cavity. Leave the batt in-place at the bottom of the wall, when you pull the fill tube out of the cavity. This piece of batt acts as temporary gasket for the hose and insulates the very bottom of the cavity after the hose is removed. This batt also eliminates the need to blow fiberglass insulation all the way to the bottom, preventing possible spillage and overfilling. If you happen to overfill the bottom of the cavity, reach up inside the wall to pack or remove some fiberglass insulation, particularly any that lies between the loose siding and studs.
5. Draw the tube down and out of the cavity about 6 inches at a time. Listen for the blower fan to indicate strain from back-pressure in the wall. Watch for the fiberglass insulation to slow its flow rate through the blower hose at the same time. Also watch for slight bulging of the exterior siding. These signs tell the installer when to pull the tube down.

- Carefully refasten the siding using the same holes. Use screws that are slightly longer and thicker than the original screws.

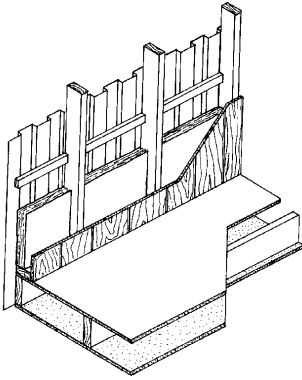

Standard mobile home construction: 2-by-4 walls and 2-by-6 floor joists are the most common construction details.

Adding insulation to mobile home walls: A contractor uses a fill tube to install more insulation in a partially filled mobile home wall.



11.4.3 Mobile Home Floor Insulation

SWS Details: 4.03 Floors

The original insulation is usually fastened to the bottom of the floor joists, leaving much of the cavity uninsulated and subject to convection currents. This reduces the insulation R-value.

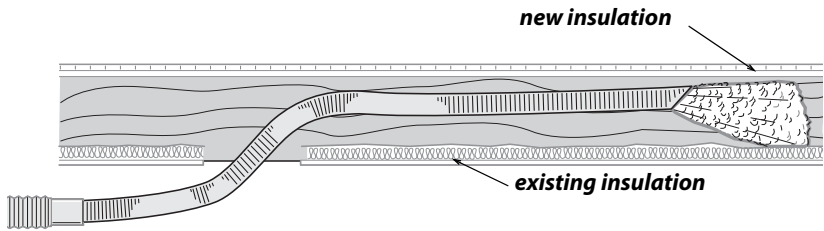

Blowing bellies: A flexible fill-tube, which is significantly stiffer than the blower hose, blows fiberglass insulation through a hole in the belly from underneath the home.

Preparing for Mobile Home Floor Insulation

Prior to installing floor insulation, always perform these repairs.

- ✓ Repair plumbing leaks.
- ✓ Attach sagging plumbing to bottom of floor framing.
- ✓ Seal all holes in the floor.
- ✓ Inspect and seal ducts.
- ✓ Repair the rodent barrier.
- ✓ When required, install a ground-moisture barrier.

Patching the Belly

Mobile homes have two common types of belly covering: rigid fiber board and flexible paper or fabric. The fiberboard is normally stapled to the bottom of the floor joists. To patch a rigid belly, simply screw or staple plywood or another rigid material over the hole.

Flexible belly material may have no solid backing behind the hole or tear because the material forms a bag around the main duct, which is installed below the floor joists. Depending on the size of the home, installers may need to use adhesive, stitch staples, and other mechanical fasteners to bind the flexible patch to the flexible belly material.

Insulating the Floor



Patching a flexible belly: The technician uses both adhesive and stitch staples to fasten a patch.

Blowing a floor through the belly:

The contractor inserts a rigid fill tube through the belly to blow insulation into the floor cavity and underbelly.



Two methods of insulating mobile home floors are common. Blown fiberglass insulation will be used. Do not insulate mobile home floors with cellulose insulation.

1. Drilling through the 2-by-6 rim joist and blowing fiberglass through a rigid fill tube into the belly.
2. Blowing fiberglass insulation through a flexible fill tube or a rigid fill tube into the underbelly.

First repair all holes in the belly. Use mobile home belly-paper or flex mend tape, sealant, or flex mend belly patch tape and cinch staples. Attach patches using outward clinch staples ("cinch staples") spaced no more than 2" apart. Use these same patches over the holes cut for fill-tubes. Screw wood lath over weak areas if needed.

When blowing through holes from underneath the home, consider blowing through damaged areas before patching them. Clean insulation from the top side of the ground cover if it was installed before insulating the belly.

Identify any plumbing lines and avoid installing insulation between them and the living space if freezing could be an issue.

Unfaced fiberglass batts may also be used to insulate floor sections where the insulation and belly are missing. The insulation should be supported by lath, twine, or insulation supports. The belly board should then be replaced under the area where the batts are installed. This is a good approach when it isn't cost-effective to insulate the entire belly.

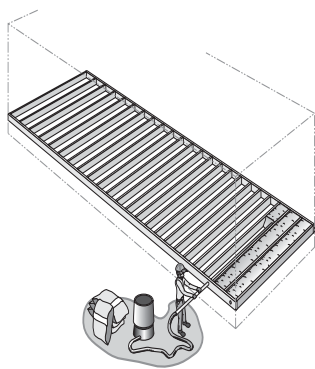

Blowing crosswise cavities:
Blowing insulation into belly is easy if the floor joists run crosswise. However, the dropped belly requires more insulation than a home with lengthwise joists.

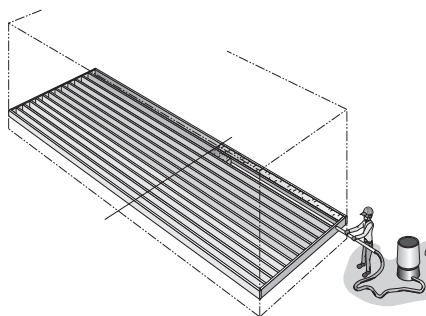

Blowing lengthwise cavities:
Floors with lengthwise joists can rarely be filled completely from the ends because of the long tubing needed. The middle can be filled from underneath.

11.5 MOBILE HOME WINDOWS AND DOORS

SWS Detail: 3.0201 Windows; 3.0202 Doors

Repairing or replacing mobile home windows and doors is often part of a mobile home weatherization job. Installing storm windows or replacing existing windows is expensive per square foot and isn't as cost-effective as insulation. Storm windows

and replacement windows are all energy conservation measures for mobile homes that are worth considering.

11.5.1 Mobile Home Storm Windows

SWS Detail: 3.0201 Windows

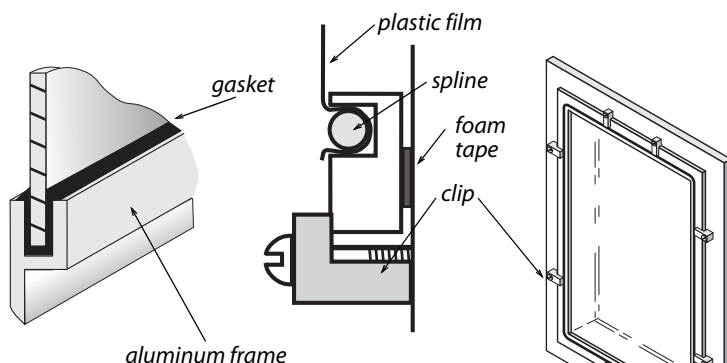

Glass interior storms:
Traditional mobile home storm windows have aluminum frames glazed with glass.

Plastic storms: Some newer Storm window designs use a lightweight aluminum frame and flexible or rigid plastic glazing.

Interior storm windows are common in mobile homes. These stationary interior storms serve awning and jalousie windows. Sliding interior storm windows pair with exterior sliding prime windows.

- ✓ Interior storm windows double the R-value of a single-pane window. They also reduce infiltration, especially in the case of leaky jalousie prime windows.
- ✓ Interior storm windows must be operable and egress-rated in egress locations. *See “Fire Egress Windows”*
- ✓ Consider repairing existing storm windows rather than replacing them unless the existing storm windows can't be re-glazed or repaired.

- ✓ When sliding primary windows are installed, use a sliding storm window that slides from the same side as the primary window. Sliding storm windows stay in place and aren't removed seasonally, and are therefore less likely to be lost or broken.

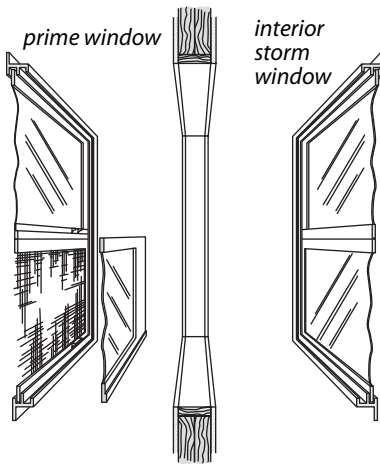

Mobile home double window: In mobile homes, the prime window is installed over the siding outdoors, and the storm window is installed indoors.

11.5.2 Replacing Mobile Home Windows

SWS Details: 3.0201 Windows

Replacement windows should have lower U-factors than the windows they are replacing. Inspect condition of rough opening members before replacing windows. Replace deteriorated, weak, or waterlogged framing members.

Prepare the replacement window by lining the perimeter of the inner lip with $\frac{1}{8}$ -inch thick putty tape. Caulk exterior window frame perimeter to wall after installing the window.

11.5.3 Mobile Home Doors

SWS Detail: 3.0202 Doors

Mobile home doors come in two basic types: the mobile home door and the house-type door. Mobile home doors swing outwardly, and house-type doors swing inwardly. House-type doors are available with pre-hung storm doors included.

Existing or replacement mobile home doors should be air-tight, water-tight, and easy to operate.

- ✓ Replace missing or damaged weatherstripping, drip cap, or flashing to ensure that water or air can't penetrate the opening.
- ✓ Properly adjust the door so that it closes securely, but does not crush or deform its weatherstripping.

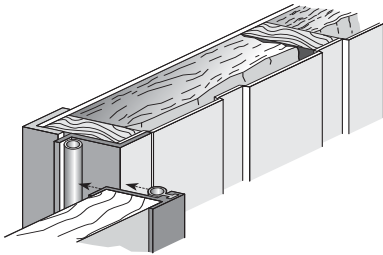

Mobile home door: Mobile home doors swing outwardly and have integral weatherstrip.

11.6 MOBILE HOME SKIRTING

SWS Detail: 4.0388.1 Foundation Skirting

The primary purpose of skirting is to keep animals out of the crawl space. Skirting must be vented to reduce moisture accumulation in many climate.

CHAPTER 12: AIR LEAKAGE DIAGNOSTICS

This chapter focuses on pressure-testing homes, to determine their airtightness and to guide air-sealing during weatherization. The air barrier and insulation must be aligned. The airtightness of the air barrier has a substantial effect on comfort, energy efficiency, and performance of the insulation.

12.1 SHELL AIR-LEAKAGE FUNDAMENTALS

Controlling air leakage is a concern for successful weatherization. The decisions you make about sealing air leaks affect the building performance. Air leakage has these impacts.

- Increased heat loss.
- Reduction of the R-value of insulation.
- Increased moisture migration through building assembly.
- House pressurization imbalance.

Air Leakage and Ventilation

Homes depend on ventilation to provide outdoor air for diluting pollutants and admitting fresh air. Air leaks can also bring pollutants into the home. Mechanical ventilation is an efficient way to provide fresh air.

“ASHRAE Standard 62.2–2016 Ventilation”

12.1.1 Goals of Air Leakage Testing

- Air-leakage and pressure testing measures the home’s airtightness level.
- It evaluates the home’s ventilation requirements.
- It helps determine the most cost effective air leakage and duct-leakage reductions.
- It helps determine the more effective air barrier, e.g, ceiling vs roof deck, floor vs foundation wall, etc

*Where is the primary air barrier:
at the rafter or ceiling joist?*

*Are the intermediate
zones connected?*

*Are the floor cavities
connected to
outdoors?*

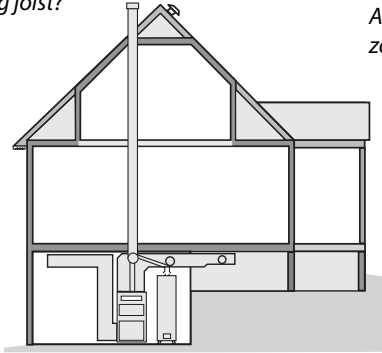

*Do ducts supply
heated air to the
addition?*

*Is the half-basement inside or outside the air
barrier? Is this space heated?*

*Are the crawl space ducts inside or
outside the air barrier?*

Questions to ask during an air-leakage evaluation: Your answers help determine the most efficient and cost-effective location for the air barrier.

Air Sealing with Air Leakage Testing

Prioritize air sealing tasks. Seal large air leaks that pass directly through the thermal boundary first. Refer to the IHCDCA blower door guidance to aid in determination for cost effective sealing.

- ✓ Perform blower door testing.
- ✓ Utilize IHCDCA blower door guidance and energy modeling software for cost effectiveness.
- ✓ Locate and seal the air leaks using blower door directed air sealing.
- ✓ Refer to the ASHRAE Standard for air sealing garages attached to living space.
- ✓ It highly recommended that the auditor, the crew leader and the QCI each complete the "Open a Door" form on dwellings with attached garages.

12.2 SINGLE-FAMILY AIRTIGHTNESS TESTING

The blower door measures a home's leakage rate at a standard pressure of 50 pascals. The blower door allows the auditor to test the home's air barrier to locate air leaks.

Blower Door Components

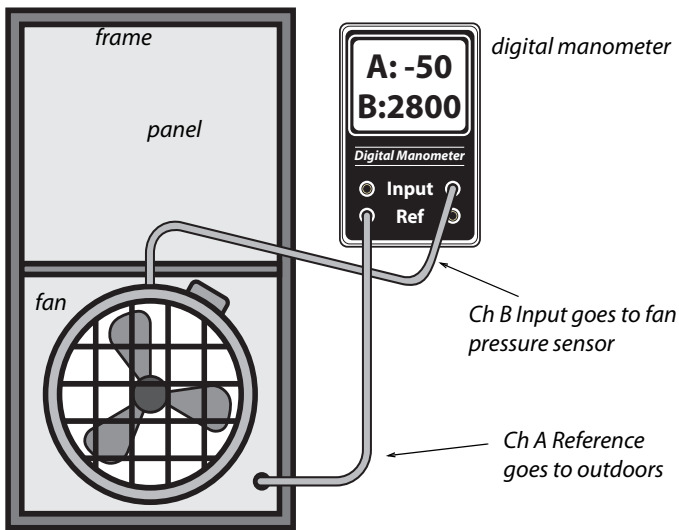

12.2.1 Blower Door Principles

The blower door creates a 50-pascal pressure difference across the building shell and uses a manometer to measure fan pres-

sure in order to calculate airflow in cubic feet per minute (CFM₅₀) to estimate the leakiness of homes. The blower door also creates pressure differences between rooms in the house and intermediate zones like attics and crawl spaces. These pressure differences can give clues about the location and combined size of a home's hidden air leaks.

Blower door test: Air barriers are tested during a blower-door test, with the house at a pressure of 50 pascals negative with reference to outdoors. This house has 2800 CFM₅₀ of air leakage. Further diagnostic tests can help determine where that leakage is coming from.

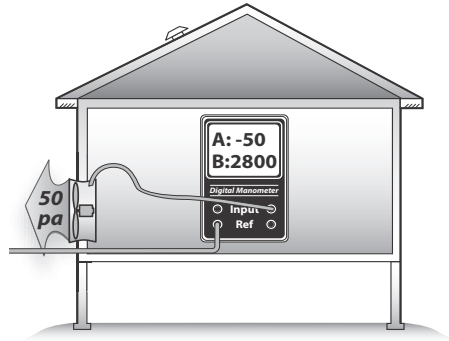

Blower Door Terminology

Connecting the digital manometer's hoses correctly is essential for accurate testing.

This method uses the phrase *with-reference-to (WRT)*, to distinguish between the input zone and reference zone for a particular measurement.

For example, *house WRT outdoors = -50 pascals* means that the house (input is 50 pascals negative compared to the outdoors (reference or zero-point. This pressure reading is called the house pressure.

Low-Flow Rings

During the blower door test, the manometer measures fan pressure to calculate airflow through the fan. This airflow (CFM₅₀) is the primary measurement of a home's airtightness and is directly proportional to the surface area of the home's air leaks. For the manometer to calculate airflow accurately, the airflow through the fan housing must be flowing at an adequate speed. Tighter buildings and smaller buildings don't have enough air leakage to create an adequate airspeed to create the minimum fan pressure. This low flow condition requires using one or two low-flow rings, to reduce the blower door fan's opening and to increase air speed, fan pressure, and measurement accuracy.

When the air speed is too low, the manometer displays "LO" in the Channel B display. After installing one of the low-flow rings, follow the manufacturer's instructions for selecting the proper range or configuration on the digital manometer.

12.2.2 Preparing for a Blower Door Test

Preparing the house for a blower door test involves putting the house in its normal heating season operation with all conditioned zones open to the blower door. Try to anticipate safety problems that the blower door test could cause, particularly with combustion appliances.

- Identify the location of the thermal boundary and determine which house zones are conditioned.
- Identify large air leaks that could prevent the blower door from achieving adequate pressure, such as a pet door.
- Put the house into its heating season operation with windows, doors, and vents closed and air registers open.
- Turn off or set to pilot, all combustion appliances.
- Open interior doors so all areas inside the thermal boundary are connected to the blower door.

Avoiding Risky Situations

Do not perform a blower door test in the following situation:

- A wood stove or fireplace is burning.
- Loose ash is present in a fireplace or wood stove.
- Extremely weak building components, like a poorly installed suspended ceiling or loose wood wall paneling.
- Lead or suspected/confirmed asbestos dust is present.
- Urea formaldehyde foam dust is present in the building components.

You must perform a blower door pressurization test when friable asbestos or suspected asbestos is present.

12.2.3 Blower-Door Test Procedures

Follow this general procedure when performing blower door testing.

- ✓ Set up the house for winter conditions.
- ✓ Install blower door frame, panel, and fan in an exterior doorway with a clear path to outdoors.
- ✓ Follow manufacturer's instructions for fan orientation and setup for either pressurization or depressurization.
- ✓ Connect Channel B-Input to fan and manometer.
- ✓ Connect Channel A-Reference to manometer and the outside of the dwelling.
- ✓ The Channel A hose outside must be at least 5 feet away from the fan, must not be in front of the fan, and should be as close to the house as possible.
- ✓ Ensure that children, pets, and other potential interferences are at a safe distance from the fan.

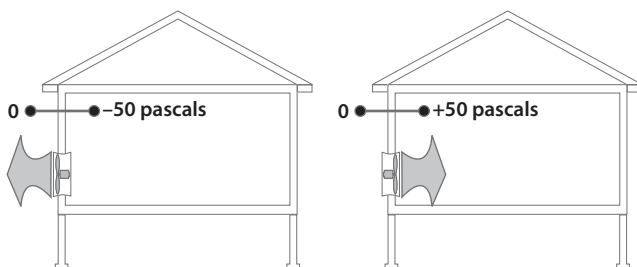

Conducting the Blower Door Test

Follow these instructions for performing a blower door test, when using a DG700 digital manometer.

1. Turn on the manometer by pushing the ON/OFF button.
2. Select the MODE: PR/FL@50.
3. Select the correct DEVICE that matches the blower door you're using.
4. With the fan covered, conduct the BASELINE procedure to cancel out the background wind and stack pressures. Let the manometer average the baseline pressure for at least 30 seconds.
5. Remove the cover from the blower door fan. Complete the next two steps for tighter buildings.
6. Install the flow ring in the blower door fan which matches the expected flow rate. The fan pressure should be at least 25 Pa while measuring CFM@50.
7. Push CONFIG button until you match the flow ring being used.
8. Turn on the blower door fan slowly with the controller. Increase fan speed until the building depressurization on the -50 pascals.

9. The Channel B screen will display the single-point CFM₅₀ air leakage of the building. If this number is fluctuating a lot, push the TIME AVG button to increase the averaging time period. Do NOT push the button until the house has reached -50 pascals.
10. You can also use the cruise-control function to auto-matically control the fan speed to create and hold -50 pascals of pressure.

Blower Door Test Follow-Up

Be sure to return the house to its original condition.

- ✓ Inspect combustion appliance pilot lights to ensure that blower door testing didn't extinguish them.
- ✓ Reset thermostats of heaters and water heaters that were turned down for testing.
- ✓ Document the location where the blower door was installed.
- ✓ Document any unusual conditions affecting the blower door test.

12.2.4 Approximate Leakage Area

There are several ways to convert blower-door CFM₅₀ measurements into square inches of total leakage area. A simple and rough way to convert CFM₅₀ into an approximate leakage area (ALA is to divide CFM₅₀ by 10. The ALA can help you visualize the size of openings in a home or section of a home.

$$\text{ALA (SQUARE INCHES)} = \text{CFM}_{50} \div 10$$

12.3 MULTIFAMILY AIRTIGHTNESS TESTING

Air sealing, indoor air quality, and fire safety complement one another in multifamily buildings. Beyond sealing leaks in the exterior envelope, the most universal concept in multifamily air sealing and airtightness testing is compartmentalization. Compartmentalization means sealing the air leaks between dwelling units to provide these benefits.

- Prevent odors traveling from one dwelling unit to another.
- Prevent the rapid spread of fire and smoke from one dwelling to another.
- Save energy by sealing air leaks and reducing the stack effect.

Leak-testing multifamily buildings is considerably more difficult than testing single-family homes. A whole-building blower door test is the ideal, but is often impossible because of the huge airflow needed to pressurize the building along with the practical problems of testing a building with many occupants. These practical problems often necessitate zone testing and compartmentalization testing.

12.3.1 Testing Equipment

- The quality and quantity of test equipment and the experience of the testing technicians determines the effectiveness of the testing. The larger the building, the more air-moving horse-power and technology the testing equipment requires.
- Several software packages can automate the process of monitoring multiple blower doors and tracking pressures throughout a large building. Wireless sensors and wireless gauges make the process of remote measurement more practical.
- Detailed instructions about operating a large-building air-leakage testing system are beyond the scope of this field guide.

Multifamily Air-Leak Locations

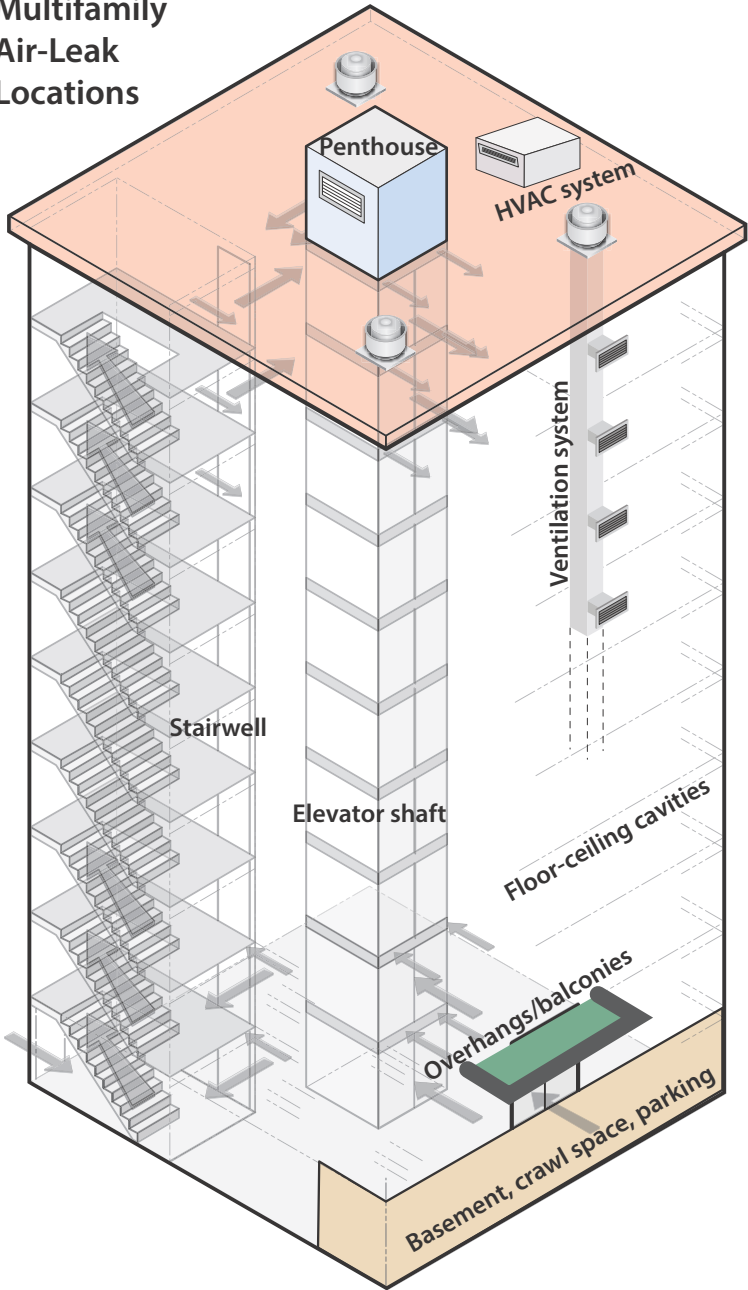

12.3.2 Multifamily Air Leakage

Energy auditors develop an air sealing strategy by evaluating the chase leakage, according to the presence and location of the following building components.

- Direct air leakage through roofs, walls, and foundations.
- Vertical chases; including stairs and elevators
- Leaks through floors allowing airflow from one floor to another.

See the following sections for more information on multifamily air leakage.

- *“Weatherization Materials”*
- *“Air-Sealing Attics and Roofs”*
- *“Air Sealing Walls”*
- *“Air Sealing Foundations and Floors”*

12.3.3 Multifamily Blower-Door-Test Strategies

Here we discuss three different strategies for blower-door testing a multifamily building: the whole-building test, the compartmental test, and the guarded test.

Testers also measure zonal pressures to evaluate air barriers in multifamily buildings, like they do in single-family dwellings.

Whole-Building Test

Although increasingly difficult as buildings get larger, the whole-building blower door test is a preferred approach. The testers usually need multiple blower doors for this test along with an automated blower-door-testing system.

The whole-building test provides an air-leakage measurement for the entire building. Also, this blower-door test gives the best information about where the critical leaks to outdoors are located.

Compartmental Test

The compartmental test requires only one blower door. This test measures air leakage to both the outdoors and indoors.

The compartmental approach gives the energy auditor a sample of the air leaks in a single dwelling unit. The leaks in this single unit may inform the auditor about typical leaks in all dwelling units or in units with the same characteristics.

Guarded Test

Testers use the guarded test when they want to measure a single dwelling unit's air leakage to outdoors. This test is another strategy to characterize a single unit—like the compartmental test—by only measuring leakage to outdoors. This test requires pressurizing surrounding dwelling units with the same pressure applied to the tested unit.

Zonal Pressures

Creating and measuring zonal pressures is one of the most effective ways to evaluate air leakage in multifamily buildings. Testers observe the building's assemblies and architectural features and formulate assumptions and questions to guide their air-leakage testing and air sealing.

The testers may decide to isolate various zones and assemblies to determine their individual leakage to outdoors or to adjacent

zones. The goal is a testing and air-sealing process that is cost-effective. The tests may be quantitative or qualitative. Here are some zones and assemblies that you may want to pressure-test.

- Stairwells and elevator shafts.
- Ventilation and HVAC ducts, duct joints, and duct chases.
- Overhangs and balconies.
- Basements, crawl spaces, and penthouses.
- Floor and ceiling cavities.

The next section, *“Testing Air Barriers”*, gives many examples of zone pressure testing.

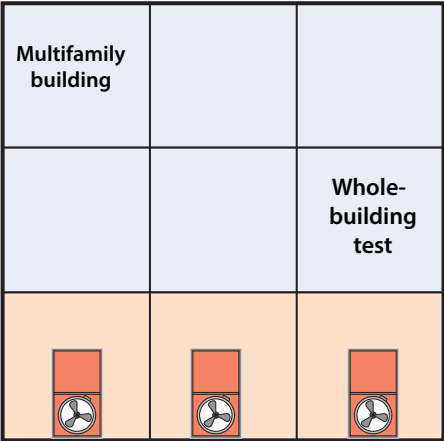

Whole-building test: Multiple blowers in entrances pressurize the whole building at once. A preferred method but sometimes impractical in existing buildings.

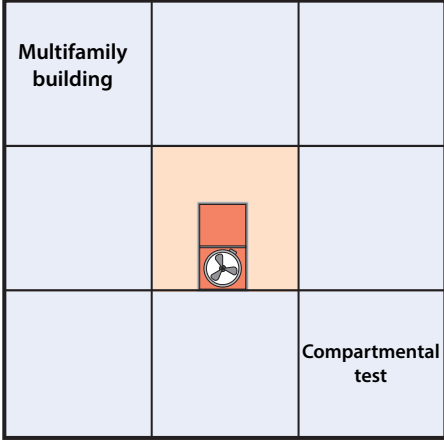

Compartmental test: A single blower door pressurizes a single dwelling unit. Identifies features of the unit that leak air to the outdoors and to surrounding units.

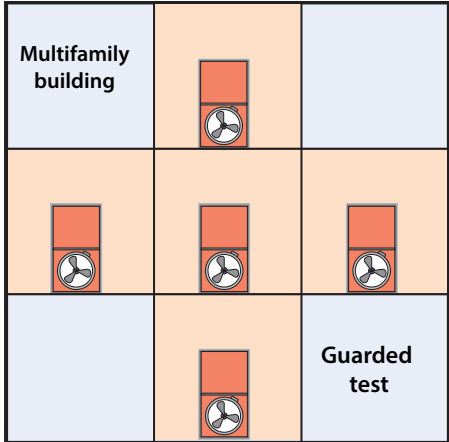

Guarded test: Attempts to measure the leakage to outdoors of a single dwelling unit. One blower door measures the units air leakage while other blower doors pressurize adjacent units to the same negative or positive pressure.

Based on Sean Maxwell

12.4 TESTING AIR BARRIERS

Leaks in air barriers cause energy and moisture.

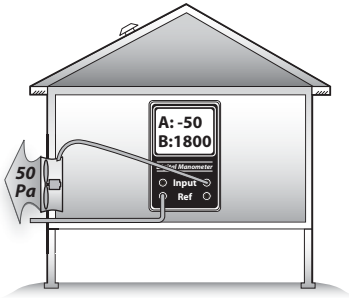

Blower door test: Air barriers are tested during a blower-door test, with the house at a pressure of 50 pascals negative with reference to outdoors. This house has 1800 CFM₅₀ of air leakage. Further diagnostic tests can help determine where that leakage is coming from.

Advanced pressure tests measure pressure differences between zones in order to estimate air leakage between zones. Use these tests to make decisions about where to direct air sealing.

- Evaluate the airtightness of a building's air barrier, including floors, ceilings, knee walls, and attached garages.
- Determine where to air seal based on zone pressure diagnostics, "add a hole"/"open a door" forms, energy modeling and common sense.
- Determine whether building cavities such as porch roofs, floor cavities, and overhangs are conduits for air leakage.
- Determine whether building cavities and ducts are connected through air leaks.
- Estimate the air leakage in CFM₅₀ through a particular air barrier for the purpose of estimating the effort and cost necessary to seal the leaks.

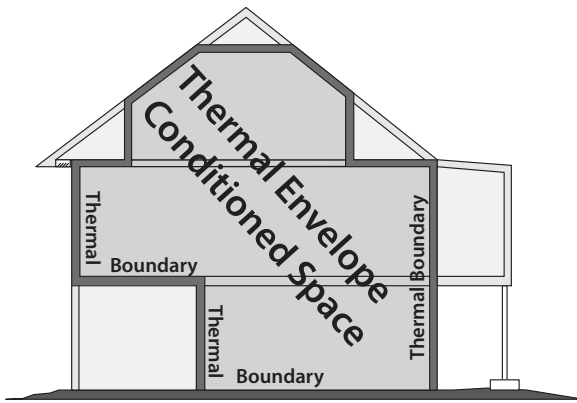

Air Barrier Test Results

Air barrier tests provide a range of information from simple clues about which parts of a building leak the most, to specific estimates of the airflow and hole size through a particular air barrier.

12.4.1 Simple Pressure Tests

Blower door tests give us valuable information about the relative leakiness of rooms or sections of the home. Listed below are five simple methods.

1. *Feeling zone air leakage:* Close an interior door partially so that there is a one-inch gap between the door and door jamb. Feel the airflow along the length of that crack, and compare that airflow intensity with airflow from other rooms, using this same technique.
2. *Observing the ceiling/attic floor:* Pressurize the home and observe the top-floor ceiling from the attic with a good flashlight. Air leaks will show in movement of loose-fill insulation, blowing dust, moving cobwebs, etc. You can also use a small piece of tissue paper or smoke generator to disclose air movement. An infrared camera also works well for identifying leakage areas during heating and cooling seasons.
3. *Observing smoke movement:* Pressurize the home and observe the movement of smoke through the house and out of its air leaks.
4. *Room pressure difference:* Check the pressure difference between a closed room or zone and the main body of a home. Larger pressure differences indicate larger potential air leakage within the closed room or else a

tight air barrier between the room and main body. A small pressure difference means little leakage to the outdoors through the room or a leaky air barrier between the house and room.

5. *Room airflow difference:* Measure the house CFM₅₀ with all interior doors open. Close the door to a single room, and note the difference in the CFM₅₀ reading. The difference is the approximate leakage through that room's air barrier.

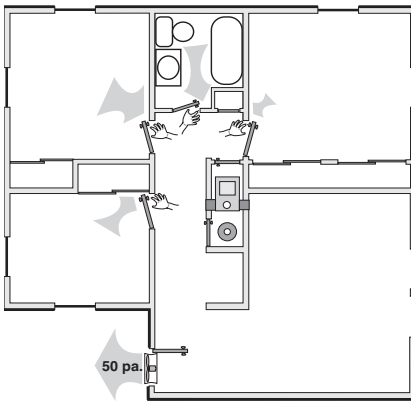

Interior door test: Feeling airflow with your hand at the crack of an interior door gives a rough indication of the air leakage coming from the outdoors through that room.

Tests 1, 2, and 3 present good client education opportunities. Feeling airflow or observing smoke are simple observations, but have helped identify many air leaks that could otherwise have remained hidden.

When airflow within the home is restricted by closing a door, as in tests 4 and 5, it may take alternative indoor paths that render these tests somewhat misleading. Only practice and experience can guide your decisions about the applicability and usefulness of these general indicators.

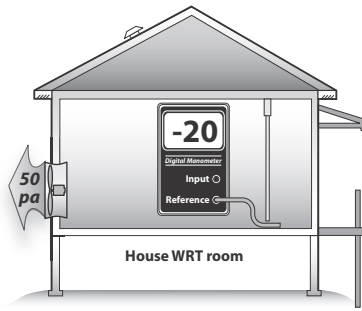

Bedroom test: This bedroom pressure difference may be caused by its leaky exterior walls or tight interior walls, separating it from the main body of the home. This test can determine whether or not a confined combustion zone is connected to other rooms.

12.4.2 Simple Zone Pressure Testing

Manometers aren't limited to finding indoor WRT outdoor differences. They can also measure pressure differences between the house and its intermediate zones during blower-door tests. The purpose of these tests is to evaluate the air-tightness of the home's interior air barriers.

The blower door, when used to create a house-to-outdoors pressure of -50 pascals, also creates house-to-zone pressures of between 0 and -50 pascals in the home's intermediate zones. The amount of depressurization depends on the relative leakiness of the zone's two air barriers.

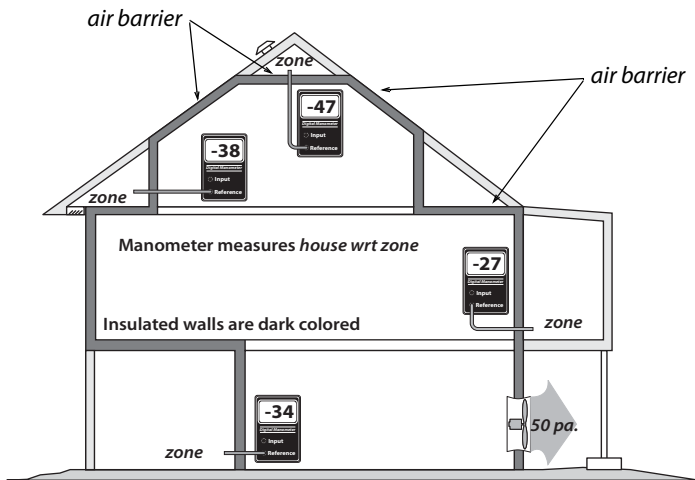

Pressure-testing building zones: Measuring the pressure difference across the assumed thermal boundary (*house wrt zone*) tells you whether the air barrier and insulation are aligned. If the manometer reads close to -50 pascals, the air barrier and insulation are aligned and the tested zones are well-connected to outdoors.

The leakier the ceiling and the tighter the roof, the smaller that the negative house-to-zone pressure will be. This holds true for other zones like crawl spaces, attached garages, and basements.

Zone Leak-Testing Methodology and Diagnostics

Depressurize house to -50 pascals with a blower door.

1. Find an existing hole, or drill a hole through the floor, wall, or ceiling between zones.
2. Connect the reference port of a digital manometer to a hose reaching into the zone.
3. Leave the input port of the digital manometer open to the indoors.

4. Read the negative house to zone pressure given by the manometer.
5. Readings of negative 25-to-50 pascals house-to-attic pressure mean that the ceiling is tighter than the roof. If the roof is almost completely airtight, achieving a 50-pascal house-to-attic pressure difference may be difficult. However if the roof is well-ventilated, achieving a near-50-pascal difference should be possible.
6. Readings of negative 0-to-25 pascals house-to-attic pressure mean that the roof is tighter than the ceiling. If the roof is well-ventilated, the ceiling has even more leakage area than the roof's vent area.
7. Readings around -25 pascals house-to-attic pressure indicate that the roof and ceiling are equally airtight or leaky.
8. For an estimation of your target for air sealing, [See "Pressure Diagnostics – Hole Size Ratios"](#)
9. Air sealing should be performed as necessary, until the pressure is as close to -50 pascals as possible.
10. The thermal boundary and air barrier are to be continuous and in alignment with each other.

Interpreting house-to-zone pressure: The greater the negative number the better the air barrier is performing.

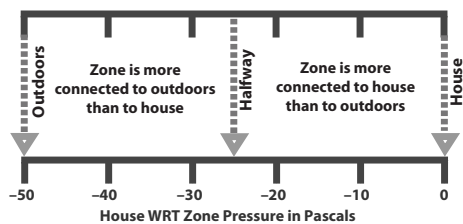

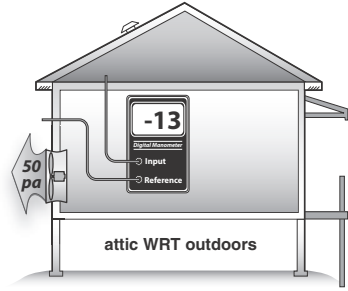
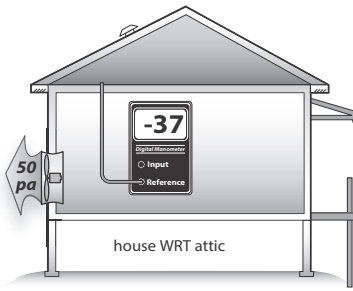

House-to-attic pressure: This commonly used measurement is convenient because it requires only one hose.

Attic-to-outdoors pressure: This measurement confirms the first because the two add up to -50 pascals.

Leak-Testing Building Cavities

Building cavities such as wall cavities, floor cavities between stories, and dropped soffits in kitchens and bathrooms can also be tested as described above to determine their connection to the outdoors as shown here.

These examples assume that the manometer is outdoors with the reference port open to outdoors

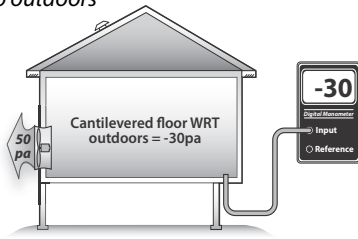
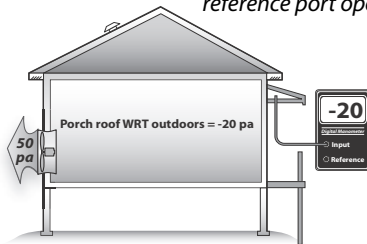

Porch roof test: If the porch roof were outdoors, the manometer would read near 0 pascals. We hope that the porch roof is outdoors because it is outside the insulation. We find, however, that it is partially indoors, indicating that it may harbor significant air leaks through the thermal boundary.

Cantilevered floor test: We hope to find the cantilevered floor to be indoors. A reading of -50 pascals would indicate that it is completely indoors. A reading less negative than -50 pascals is measured here, indicating that the floor cavity is partially connected to outdoors.

Testing Zone Connectedness

Sometimes it's useful to determine whether two zones are connected by a large air leak. Measuring the house-to-zone pressure during a blower door test, before and then after opening the other zone to the outdoors, can establish whether the two zones are connected by a large air leak. You can also open an interior door to one of the zones and check for pressure changes in the other zone.

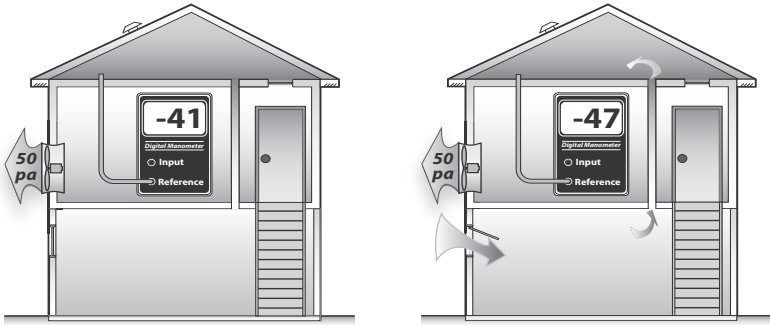

Zone connectedness: The attic measures closer to outdoors after the basement window is opened, indicating that the attic and basement are connected by a large bypass.

The
End

APPENDICES

A-1 R-VALUES FOR COMMON MATERIALS

Material	R-value
Fiberglass or rock wool batts and blown 1"	2.8–4.0
Blown cellulose 1"	3.0–4.0
Vermiculite loose fill 1"	2.7
Perlite 1"	2.4
White expanded polystyrene foam (beadboard) 1"	3.9–4.3
Polyurethane/polyisocyanurate foam 1"	6.2–7.0
Extruded polystyrene 1"	5.0
High-density 2-part polyurethane foam 1"	5.8–7.5
Low-density 2-part polyurethane foam 1"	3.6
Oriented strand board (OSB) or plywood 1/2"	1.6
Concrete or stucco 1"	0.1
Wood 1"	1.0
Carpet/pad 1/2"	2.0
Wood siding 3/8–3/4"	0.6–1.0
Concrete block 8"	1.1
Asphalt shingles	0.44
Fired clay bricks 1"	0.1–0.4
Gypsum or plasterboard 1/2"	0.4
Single pane glass 1/8"	0.9
Low-e insulated glass (Varies according to Solar Heat Gain Coefficient (SHGC) rating.)	3.3–4.2

A-2 ASHRAE 62.2 DUCT SIZING

Rated Fan CFM

50	80	100	125	150	200	250	300
-----------	-----------	------------	------------	------------	------------	------------	------------

Duct Dia.	Smooth Hard Duct - Maximum Duct Length in Feet							
3"	5	X	X	X	X	X	X	X
4"	114	31	10	X	X	X	X	X
5"	NL	152	91	51	28	X	X	X
6"	NL	NL	NL	168	112	53	25	9
7"	NL	NL	NL	NL	NL	148	88	54
8"	NL	NL	NL	NL	NL	NL	198	133

Duct Dia.	HVAC Flex Duct - Maximum Duct Length in Feet							
3"	X	X	X	X	X	X	X	X
4"	56	4	X	X	X	X	X	X
5"	NL	81	42	16	2	X	X	X
6"	NL	NL	158	91	55	18	1	X
7"	NL	NL	NL	NL	161	78	40	19
8"	NL	NL	NL	NL	NL	189	111	69

NL: No limit;

X: not allowed

Table assumes no elbows. Deduct 15 ft from allowable duct length for each elbow.

A-3 FIRE TESTING AND RATING

Test/Rating	Description
ASTM E-136 or E-176	If a material passes this test, it is non-combustible.
ASTM E-119	Hourly rating of a wall when exposed to fire. Determines how long that the wall holds back heat and flames and maintains its structural integrity.
ASTM E-184	Hourly rating for a sealant system for a penetration through a fire-rated (ASTM E119) assembly.
ASTM E-84	Test measures how fast flames spread in a fire tunnel lined with the tested material, compared to red oak, which is given a flame spread of 100. This test classifies materials as Class I, II, or III (or A, B, & C) See flame spread in the three rows below.
Class I or A	Flame spread less than or equal to 25
Class II or B	Flame spread 26 to 75
Class III or C	Flame spread 76 to 200
FM 4880 or UL-1040	The fire burns in a 90-degree corner of a wall assembly containing the tested material. Approximates the performance of a material installed in a typical building assembly. The test measures the fire resistance of an assembly in 15 minutes of fire exposure at 40 kW and 160 kW.
ISO 9705 UL 1715	Like the corner test except the fire burns in a room with its wall and ceiling assembly sheeted with the tested finish material. The measures time with flame spread and smoke developed ratings relative to Class I, II, and III assemblies.
UL181	Duct materials, duct-closure systems, and duct sealants so labeled pass UL fire-resistance tests.

A-4 CARBON MONOXIDE LIMITS

Based on ANSI BSR/BPI-1200-S-201x

Equipment	CO Limit
Central Furnace (all categories)	200 ppm as measured; 400 ppm air free; PMI
Boiler	200 ppm as measured; 400 ppm air free; PMI
Floor Furnace	200 ppm as measured; 400 ppm air free; PMI
Gravity Furnace	200 ppm as measured; 400 ppm air free; PMI
Wall Furnace (BIV)	100 ppm as measured; 200 ppm air free; PMI
Wall Furnace (Direct Vent)	100 ppm as measured; 200 ppm air free; PMI
Vented Room Heater	100 ppm as measured; 200 ppm air free; PMI
Unvented Room Heater	100 ppm as measured; 200 ppm air free; PMI
Water Heater	100 ppm as measured; 200 ppm air free; PMI
Oven / Broiler	225 ppm as measured
Clothes Dryer	200 ppm as measured; 400 ppm air free; PMI
Refrigerator	25 ppm as measured
Gas Log (gas fireplace)	25 ppm as measured in vent
Gas Log (installed in wood burning fireplace)	400 ppm air free in firebox

In Indiana, 100 PPM for central furnaces, boilers, floor and wall furnaces triggers a clean and tune to reduce the CO. For range top burners, the CO limit is 100 PPM.

A-5 REFRIGERATOR DATING CHART

Refrigerators are listed by brand name, followed by the coding system. If several manufacturers used the same system, they are listed together. Some rules of thumb for easy identification are: (1) Refrigerators that are any color of green, brown, yellow, pink, or blue (actually KitchenAid makes a new unit in cobalt blue) have mechanical handles; have doors held shut with magnetic strips; have rounded shoulders; have a chromed handle; or have exposed "house door" type hinges and at least 10 years old, and (2) the following brands have only been manufactured since around 1984 - Roper, Estate, KitchenAid, Caloric, Modern Maid, and Maytag.

Brand(s)	What to look for	What to avoid	How to decode	Example	
Montgomery Ward, Signature (2000)	Serial # - 1 st two digits	n/a	Reverse the digits	56XXXX = 1965	
Sears, Kenmore, Coldspot	Model # - 1 st & 3 rd digits after ()	n/a	Combine the digits	xx6x2xxx = 1962	
Whirlpool	Model # - 1 st 3 letters (pre 1982) Serial # - 2 nd digit (post 1982)	Serials with letters	No need as 1 st two digits Add "198" to it	ABCxxx = pre 1982 x2xxx = 1982	
Amana	Serial # - 1 st digit (pre 1986)	n/a	BLACKHORSE B=1, L=2	Hxxx = 1966 or 1976 61 is the oldest	
Frigidaire	Serial # - 1 st & 4 th digit (pre 1989)	Serials with no letter in the 4 th space	Add "196, 197, or 198" to the 1 st digit. The letter in the 4 th space is a month code used only on older models.	3xxBxx = 1973 or 1983	
Gibson, Kelvinator	Serial # - 3 rd digit (pre 1989)	n/a	Add "196, 197, or 198" to it	xx3xx = 1963 or 73 or 83	
White, Westinghouse	Serial # - 2 nd letter (pre 1989)	Serials without letters	A, V, W=78, B=79, C=80 etc. pre-1978, R=74, U=77 etc.	xLxxx = 1988 74 is the oldest year	
Tappan, O'Keefe & Merritt	Serial # - 7 th digit (pre 1989)	n/a	Add "196, 197, or 198" to it	xx xxx-88xx = 1988 or 78 or 88	
Admiral, Crosley, Norge, Magic Chef, Jenn Air	Serial # - last letter	n/a	A=1950 or 1974 (+14 yrs) B=1951 or 1975, etc.	xxxxxD = 1953 or 1977	
General Electric (GE)	Serial # - 2 nd letter	n/a	See chart below	xGxxx = 1950 or 1980	
Hotpoint	Same as GE with some exceptions. See GE and Hotpoint exceptions chart below				
GE Decoder Chart:	A = 44, 65, 77, 89 H = 51, 81, 93 R = 58, 84	B = 45, 66 J = 52 S = 59, 85	C = 46, 67 K = 53 T = 60, 74, 86	D = 47, 68, 78, 90 L = 54, 70, 82, 94 V = 61, 75, 87	E = 48, 69 M = 55, 71, 83 W = 62 F = 49, 79, 91 N = 56, 72 X = 63, Y = 64 G = 50, 80, 92 P = 57, 73 Z = 76, 88
Hotpoint Exceptions:	U = 61, V = 62, W = 63, X = 64, Y = 65, Z = 66, A = 67, B = 68				

Revised 5/6/94

A-6 DOE HEALTH AND SAFETY GUIDANCE

Weatherization Program Notice 17-7 is Effective August 9, 2017. WPN 17-7 clarifies, updates, and provides additional information related to the implementation and installation of health and safety (H&S) measures as part of the DOE WAP. This guidance also provides required components for Grantees to include in their Health and Safety Plans.

See website below for most current Federal guidance, including WPN 17-7 documents at: the following web address:
<https://www.energy.gov/eere/wap/weatherization-program-notices-and-memorandums>

A-7 PRESSURE DIAGNOSTICS – HOLE SIZE RATIOS

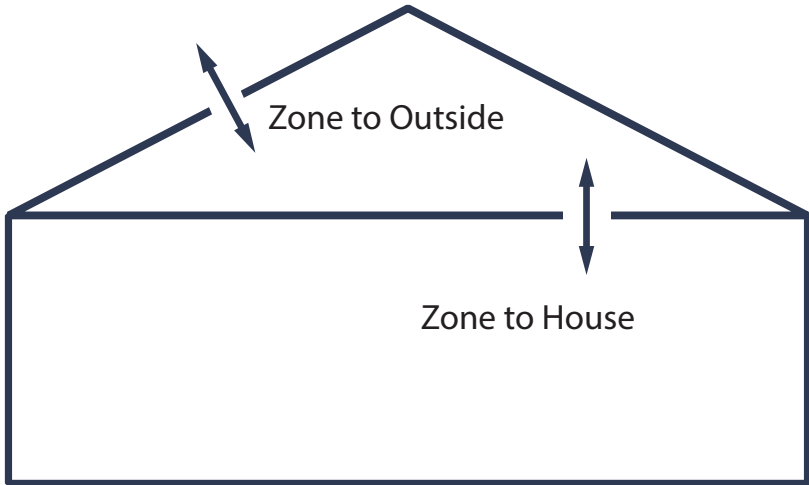

Zone Pressures (Pa.)		Relative Size of the Holes	
House-Zone	Zone-Outside	House - Zone	Zone-Outside
12	38	2	1
25	25	1	1
37	13	1/2	1
41	9	1/3	1
45	5	1/4	1
48	2	1/8	1
49	1	1/13	1

Source: Michael Blasnik and Jim Fitzgerald

A-8 HOUSE DEPRESSURIZATION CHART

spillage goes up with depressurization

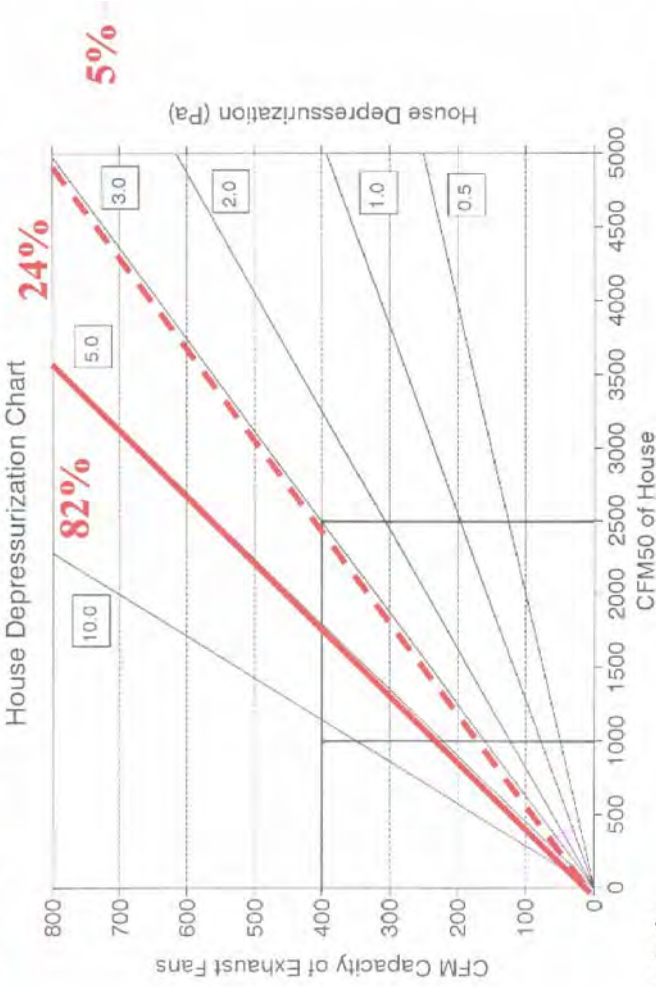

From 1075 tests in
Mpls Sound Program

GLOSSARY

Abatement : A measure or set of measures designed to permanently eliminate a hazard

Absolute humidity: Air's moisture content expressed in weight of water vapor per standard weight (pounds, grams) of dry air.

Absorptance: The ratio of a solar energy absorbed to incident solar. Also called absorbtivity.

Absorption: A solid material's ability to draw in and hold liquid, gas, or radiant energy.

Accent lighting: Illumination of walls or other surfaces, to spread light and reduce contrast in an indoor or outdoor area.

Acoustical Sealant: Sealing agent used to minimize sound transmission through a joint.

ACH50: The number of times in one hour that all of the air in a home is replaced by outside air during a 50-pascal blower door test.

Adsorption: Adhesion of a thin layer of molecules to a surface they contact.

Air barrier: Any part of the building shell that offers resistance to air leakage. The air barrier is effective if it stops most air leak-age. The primary air barrier is the most effective of a series of potential air barriers.

ACH₅₀: Air changes per hour at 50 pascals. The number of times the volume of air in a structure will change in one hour at the induced blower door house pressure of 50 pascals.

ACH_{nat}: Air changes per hour natural. The number of times the indoor air is exchanged with the outdoor air in one hour under natural driving forces.

Air conditioning: Cooling buildings with a refrigeration system. More generally means both heating and cooling.

Air Conditioning Contractors of America (ACCA): Industry group that promotes best practices and lobbies for the industry.

Air exchange: The process whereby indoor air is replaced with the outdoor air through air leakage and ventilation.

Air-free carbon monoxide (ppm): A measurement of CO in an air sample or flue gas that accounts for the amount of excess air (oxygen, O₂) in the sample. It adjusts the as-measured CO ppm value, thus simulating air-free (oxygen-free) conditions in the sample. Measured in parts per million (ppm).

Air handler: A steel cabinet containing a blower with cooling and/or heating equipment, connected to ducts that transport indoor air to and from.

Air-handling unit (AHU): See air handler.

Air leakage: Uncontrolled ventilation through gaps in the air barrier. Typical sites of air leakage include around windows, pipes, wires and other penetrations.

Air-impermeable insulation: An insulation having an air permeance equal to or less than 0.02 L/s-m² at 75 Pa pressure differential tested according to ASTM E 2178 or E 283.

Air sealing: The systematic approach to reducing air leakage in a building.

Albedo: The ratio of reflected light to incident light.

Altitude adjustment: The input modification for a gas appliance installed at a high altitude. When a gas appliance is installed more than 2000 feet above sea level, The installer may reduce its input rating according to manufacturers' specifications.

Ambient: Of the surrounding area or environment.

Ambient air: Air in the habitable space. Also the air around a human observer.

Ambient lighting: Lighting spread throughout the lighted space for safety, security, and aesthetics.

American Gas Association (AGA): A trade association representing American natural gas supply companies. AGA collaborates with ASC and NFPA on the National Fuel Gas Code.

American National Standards Institute, Inc. (ANSI): A private non-profit organization that oversees the development of voluntary consensus standards for products, services, processes, systems, and personnel in the United States.

American Recovery and Reinvestment Act (ARRA): Bill signed by President Obama in February 2009 as an economic stimulus package.

American Society of Heating, Refrigeration, and Air Conditioning Engineers (ASHRAE): A technical society for individuals and organizations interested in heating, ventilation, air-conditioning, and refrigeration. ASHRAE publishes standards and guide-lines relating to HVAC systems and issues.

American Society for Testing and Materials (ASTM) : A standards organization that develops and publishes voluntary consensus technical standards for a wide range of materials, products, systems, and services.

Amperage: The rate that electrical current flows through an appliance at any given time; also called current.

Ampere: A unit that measures the rate that electrons move through a conductor.

Anemometer: A device that measures air speed, used in HVAC work to determine flow rates at registers.

Annual Fuel Utilization Efficiency (AFUE): A laboratory-derived efficiency for heating appliances that accounts for chimney losses, jacket losses, and cycling losses, but not distribution losses, fan energy, or pump energy.

Annual return: The annual savings divided by the initial cost of an ECM, expressed as a percent.

Appliance: Any device powered by electricity or combustible fuel.

Approach temperature: The temperature difference between the fluid inside a heat exchanger and the fluid outside of it.

Aquastat: A heating control device that controls the burner or the circulator in a hydronic heating system.

Arc-fault circuit interrupter (AFCI): A circuit breaker that disconnects a circuit when it detects an electrical arc.

Area: Length x width = area.

As-measured carbon monoxide (CO): A calculation of CO in parts per million (ppm) of a combustion-gas sample with the excess air (oxygen, O₂), diluting the CO concentration removed by the calculator in the fuel-gas analyzer.

ASHRAE: American Society of Heating, Refrigerating, and Air-Conditioning Engineers. International technical society which develops standards for those concerned with refrigeration processes and the design and maintenance of indoor environments.

ASHRAE 62.2-20xx: Indoor air quality standard developed for low-rise residential buildings. Defines the roles of a minimum requirements for mechanical and natural ventilation systems and the building envelope.

Asbestos: A fibrous mineral with fireproofing and insulating characteristics manufactured into a variety of building materials. Small, sharp, asbestos fibers are a known carcinogen when inhaled.

Association of Energy Engineers (AEE): A professional organization for energy engineers. AEE offers many certification programs, including energy auditors and other energy experts.

Association of Home Appliance Manufacturers (AHAM): Trade association representing the appliance manufacturing industry

Asthma: An acquired respiratory illness with strong correlation to buildings, moisture problems, and pets.

Atmospheric appliance: A combustion appliance that burns and exhausts its combustion gases at atmospheric pressure.

Atmospheric pressure: The weight of air and its contained water vapor on the surface of the earth. At sea level this pressure is 101,325 pascals or 14.7 pounds per square inch.

Attic: The unfinished space between the ceiling assembly of the top story and the roof assembly.

Attic, habitable: A finished or unfinished area, not considered a story. See the IRC for specific requirements.

Audit: The process of identifying energy conservation opportunities in buildings.

Auxiliary heat: Electric resistance heat in a heat pump that heats the building when the compressor isn't able to provide the entire heat capacity needed for cold weather.

Awning window: Awning windows are essentially casement windows that swing vertically.

B-vent: A double-wall pipe for gas- or propane-fired combustion appliances.

Backdrafting: Continuous spillage of combustion gases from a vented combustion appliance into the conditioned space.

Backdraft damper: A damper, installed near a fan, that allows air to flow in only one direction.

Backer rod: Polyethylene foam rope used as a backer for caulking.

Baffle: 1. A lightweight plate that directs air from a soffit over attic insulation and along the bottom of the roof deck to ventilate the attic and cool the roof deck. 2. A plate or strip designed to retard or redirect the flow of flue gases.

Balance point: The outdoor temperature at which no heating is needed to maintain indoor comfort.

Ballast: A coil of wire or electronic device that provides a high starting voltage for a lamp and also limits the current flowing through it.

Belly blow: A process for re-insulating floor cavities with blown-in insulation.

Belly return: A configuration found in some mobile homes that uses the belly cavity as the return side of the heating/cooling distribution system.

Bimetal element: A metal spring, lever, or disc made of two dissimilar metals that expand and contract at different rates as the temperature around them changes. This movement operates a switch in the control circuit of a heating or cooling device.

Blocking: A construction element or material used to strengthen or to prevent the movement of air or insulation into or out of building cavities.

Block frame: A non-finned window frame for new or retrofit installation in a rough opening.

Blower door: A blower door is a diagnostic tool used to locate air leaks in the building envelope and help prioritize the air sealing protocols.

Balloon framing: A method of construction in which the vertical framing members (studs) are continuous pieces running the entire height of the wall.

Band joist: See - Rim joist

Barometric vent damper: A device installed in the heating unit vent system to control draft. Usually used on oil-fueled heaters or gas heaters with power burners

Barrier: Material used to block passage or movement.

Basement: The portion of a building that is partly or completely below grade.

Batt: A blanket of preformed fibrous insulation designed to fill cavities.

Beam: A strong horizontal building support used to carry the weight of a floor or roof.

Blow-down: The act of removing water from a boiler to remove sediment and suspended particles from the boiler water.

Blower: The squirrel-cage fan in a furnace or air handler.

Blown insulation : A loose-fill insulation that is blown into attics and building cavities using an insulation blowing machine.

Board feet: An American measurement of lumber volume. A board foot equals 144 cubic inches of wood.

Boiler: A fossil fuel appliance used for producing hot water or steam as the medium to distribute heat to the dwelling unit.

Boot: A duct section that connects between a duct and a register or between round and square ducts

Bonus room: A room that is substandard in some way and not listed in a home's salable features.

Borescope: A flexible tube with a light and camera or viewer at one end. Inspectors use borescopes to look into wall cavities and other tight spaces, otherwise impossible to inspect.

Boundary: Defines where one area ends and another begins.

Branch circuit: An electrical circuit used to power outlets and lights within a home.

Branch duct: An air duct which branches from a main duct.

Brightness: The intensity of the sensation derived from viewing a lit surface. Measured in footlamberts or candelas per square meters. It is also called luminance or luminous intensity.

British thermal unit (Btu): The quantity of heat required to raise the temperature of one pound of water one degree Fahrenheit.

BTUh : British Thermal Units per hour.

Building cavities: The spaces inside walls, floors, and ceilings between the interior and exterior sheathing

Building envelope: The area of the building that encloses its conditioned and unconditioned spaces.

Bulk moisture: Large amounts of water intrusion, for example from wind-driven rain or sub-surface water.

Burner: A device that facilitates the burning of a fossil fuel, like gas or oil.
Butyl-backed tape: Heavy-duty, pressure-sensitive sealant or gasket.

Bypass: An air leakage site that allows air to leak into or out of a building flowing around the air barrier and insulation.

Cad cell: A flame sensor composed of the chemical compound cadmium sulfide. Its purpose is to sense whether a flame is present during a burner cycle. If the cad cell doesn't detect a flame, it shuts the burner off.

Calibration: Comparison of the test results of an instrument to a known reference point.

Call-back: Having a weatherization team return to a job site to perform work not done or to redo work done unsatisfactorily.

Building Management System (BMS): Computer-based control system installed in buildings that controls and monitors the building's mechanical and electrical equipment such as air handling and cooling.

Building Performance Institute (BPI): Organization supporting the development of a highly professional building performance industry through individual and organizational credentialing and a quality assurance program.

Building science: A complex perspective on buildings, using contemporary technology to analyze and solve problems of design, construction, maintenance, safety, and energy efficiency.

Building shell: Separates a building's indoors from the outdoors.

Building Tightness Limit (BTL): Calculation procedure, expressed in units of CFM50, based on the American Society of Heating, Refrigerating and Air-Conditioning Engineers Standard 62-2001, Ventilation for Acceptable Indoor Air.

Can light: A light fixture (or can) that is set into the ceiling. Also called a recessed light fixture.

Cantilever: A projecting structure, such as a beam, that is supported at one end and carries a load at the other end or along its length.

Cantilevered floor: A floor that extends beyond the foundation of the framed structure below it.

Cape Cod: A house design featuring a finished attic space, also called a one-and-a-half story.

Capillary action: The ability of water to move through materials, even upward against gravity, through small tubes or spaces.

Capillary barrier: A material or air space designed to stop capillary action from carrying water into a building.

Carbon dioxide (CO₂): A heavy, colorless, nonflammable gas formed by the oxidation of carbon, by combustion, and by the respiration of plants and animals. One of two main products of complete combustion of a hydrocarbon (the other is water vapor).

Carbon monoxide (CO): Carbon monoxide is a tasteless, odor-less, colorless and poisonous gas that is a by-product of incomplete combustion of fossil fuels. It is usually caused by a lack of air to support combustion or impingement of the flame.

Carcinogen: A material known to cause cancer.

Casement window: Casement windows have a single operable sash that swings outward on a horizontal plane. Casement window frames that have gone out of square due to settling can stick and quite possibly render these types of windows inoperable.

Casing: Decorative molding or trim around a window or door.

Cathedral ceiling: A sloped ceiling insulated between the roof deck and the finish ceiling material.

Cathedralized attic: An attic that is insulated at the underside of the roof deck rather than at the ceiling.

Caulking: Mastic compound for filling joints and cracks.

Celsius (°C): The metric temperature scale where water freezes at 0°C and boils at 100°C.

Cellulose insulation: Insulation, packaged in bags for blowing, made from newspaper or wood waste and treated with a fire retardant.

Centigrade: See Celsius (°C)

Central heating system: The primary heating system of the dwelling unit including the heat producing appliance along with the return and supply system for heat distribution.

Certification: Recognition by an independent person or group that someone can competently complete a job or task, frequently demonstrated by passing an exam.

Certified renovator: A person authorized by the EPA to perform repair and renovation projects that disturb lead-based paint.

CFMn: The cubic feet of air flowing through a house from indoors to outdoors during typical, natural conditions.

CFM - Cubic feet per minute: An American measurement of air-flow equal to 0.472 liters per second.

Chaseway: Cavity within a building with a purpose of conveying pipes, ducts, etc. through the building. Chaseways, such as plumbing walls, are common sites for air leakage.

Chimney: A building component designed for the sole purpose of assuring combustion by-products are exhausted to the exterior of the building.

Chimney connector: A pipe that connects a fuel-burning appliance to a chimney. Also see *vent connector*.

Chimney flue: A passageway in a chimney for conveying combustion gases to the outdoors.

Chimney chase: The framing and other building materials that surround the chimney.

Circuit breaker: A device found in a Circuit Panel Box that completes an electric circuit. This breaker disconnects the circuit from electricity when it senses an overload of current.

Cladding: The exterior covering or coating on a structure, such as wood siding, stucco, or brick veneer.

Clean and tune (C&T): A procedure performed on a heating or cooling system by a qualified technician to optimize its efficiency.

Cleanout: An opening in a chimney (usually at its base to allow inspection and the removal of ash or debris.

Clearances: Allowable distances between heat-producing appliances, chimneys, or vent systems and combustible surfaces.

Climate zone: An area with a prevailing climate that distinguishes it from other areas by parameters such as temperature, rainfall, and humidity.

Codes: Any set of standards set forth and enforced for the protection of public health and humidity.

Co-efficient of performance (COP): A dimensionless number representing the ratio of a heat pump or air conditioner's output in watt-hours of heat moved divided by watt-hours of electrical input.

Coil: A snake-like piece of copper tubing surrounded by rows of aluminum fins that clamp tightly to the tubing and aid in heat transfer.

Coil stock: Sheet metal packaged as a coil in various widths.

Cold-air return: Ductwork that draws house air into the air handler for reheating by a furnace.

CFM50: The amount of cubic feet per minute of air moving through a structure and measured at 50-pascals pressure during a blower door test.

Cold roof: A roof design where the roof temperature is equalized from top to bottom by roof ventilation and/or roof insulation to prevent ice damming.

Collar beam: A horizontal piece in roof framing that provides structural strength by connecting opposite rafters.

Color rendering index (CRI): A measurement of a light source's ability to render colors the same as sunlight. CRI has a scale of 0 to 100.

Color temperature: A measurement of the warmth (redness or yellowness) or coolness (blueness or whiteness) of a light source in the Kelvin temperature scale.

Column: A vertical building support usually made of wood or steel.

Combustible: Means something will burn, although not necessarily readily.

Combustible gas leak detector: A device for determining the presence and general location of combustible gases in the air.

Combustion: The act or process of burning. Oxygen, fuel, and a spark must be present for combustion to occur.

Combustion air: Air that chemically combines with a fuel during the combustion process to produce heat and combustion gases, mainly carbon dioxide and water vapor.

Combustion analyzer: A device used to measure and analyze combustion gases for efficiency and safety.

Combustion appliance: Any appliance in which combustion occurs.

Combustion appliance zone (CAZ): The closed space or area that holds one or more combustion appliances.

Combustion appliance zone (CAZ) testing: Diagnostics performed to ensure that combustion appliances work properly and that house pressures allow combustion gases to vent.

Combustion byproducts: Gases, vapors, and particulates produced whenever carbon-based fuels are burned.

Combustion chamber: The area inside the heat exchanger where the flame burns.

Combustion efficiency: Synonymous with steady-state efficiency.

Combustion gases: Combustion byproducts.

Commissioning: The process of testing and adjusting building mechanical systems.

Common vent : The portion of the vent or chimney through which passes products of combustion from more than one appliance.

Compact fluorescent lamp (CFL): A small fluorescent light engineered to fit in an Edison base of an incandescent fixture.

Compartmentalization: Air-sealing that prevents air from migrating from one dwelling or zone of a multifamily building to another.

Competency: Demonstrated ability to perform a job or task.

Compressor: A motorized pump that compresses the gaseous refrigerant and sends it to the condenser where heat is released.

Concentrically constructed direct-vent: A direct-vent appliance that has an exhaust-gas vent and a combustion-supply-air vent arranged in a concentric fashion: one pipe is inside the other with a space between the walls of each.

Condensate: Vapor condensed back to a liquid. For example: water or refrigerant.

Condensate receiver: A tank for catching returning condensate water from a steam heating system or condensed refrigerant from a condenser.

Condense: When a gas turns into a liquid as it cools, it con-denses. When a gas condenses into a liquid it releases heat.

Conditioned air: Air that has been heated, cooled, humidified, or dehumidified to provide comfort.

Conditioned space: For energy purposes, space within a building that is provided with heating and/or cooling equipment or systems, or that communicates directly with a conditioned space. For mechanical purposes, an area, room or space being heated or cooled by any equipment or appliance.

Conductance: The quantity of heat, in BTUs, that flows through one square foot of material in one hour, when there is a one degree Fahrenheit temperature difference between both surfaces. Conductance values are given for a specific thickness of material.

Conduction: Conduction is the transfer of heat through a material by molecular vibration.

Conductivity: The quantity of heat that flows through one square foot of homogeneous material, one inch thick, in one hour, when there is a temperature difference of one degree Fahr-enheit between its surfaces.

Confined space: A space, defined for the purpose of evaluating combustion air, with a volume of less than 50 cubic feet per 1,000 BTU per hour of the total input rating of all combustion appliances installed in that space.

Contractor: Any person or entity that provides services under contract, and not as employees of the purchasing agency.

Contrast: Difference in brightness measured by the relationship between an object's brightness and the brightness of its back-ground.

Control circuit: An electrical circuit that activates or deactivates a power circuit or opens and shuts a valve.

Convection: The transfer of heat caused by the movement of a fluid like water or air. When a fluid becomes warmer it becomes lighter and rises.
Convective loop: Heat flow resulting from fluid flow between surfaces of different temperatures.

Cooling load: The maximum rate of heat removal required of an air conditioner when the outdoor temperature and humidity are at a standard worst-case outdoor condition.

Core competencies: Essential skills for weatherization workers, defined by the Weatherization Trainers Consortium.

Cost effective: Having an acceptable payback, return-on-invest-ment, or savings-to-investment ratio.

Crawl space: The low space beneath the ground floor of a building that gives workers access to wiring and plumbing.

Crew leader: A crew leader is a residential energy professional who supervises weatherization tasks specified in the scope of work.

Critical framing juncture: An intersection of framing members and envelope components that require special attention during air-sealing and insulation.

Cross section: A view of a building component drawn or imagined by cutting through the component.

Crosswise floor-joists: Mobile home joist configuration where the main duct is located beneath the floor joists and connected by boots to the sub-floor.

Cubic foot per minute (CFM): A measurement of volumetric air-flow rate. See also *CFM₅₀* and *CFMn*.

Curtain wall: A wall between *columns* and *beams* that supports no weight but its own.

Condenser: The coil in a refrigeration system where the refrigerant condenses and releases heat.

Condensing furnace: A high-efficiency furnace that removes latent heat from combustion gases by condensing water vapor out of the combustion gases.

Conditioned: Intentionally heated or cooled areas of a building.

Degree days (DD): A cumulative measurement of outdoor temperature calculated by adding the temperature differences between an indoor temperature of 65°F and the daily average outdoor temperature for a one-year period.

Delta-T: Temperature difference.

Demand: The peak need for electrical energy. Some utilities levy a monthly charge for demand.

Demand-side management (DSM): The planning and implementation of utility-sponsored conservation of electricity or gas.

Dense packing: Blowing insulation with sufficient force to create a high density to reduce settling and minimize air leakage and air convection.

Density: The weight of a material divided by its volume, usually measured in pounds per cubic foot.

Dado: A rectangular groove cut into wood to create a structural joint.

Decatherm: One million BTUs or 10 therms.

Decking: The wood material structural sheathing installed over the rafters to support the roofing.

Decommissioning: Removing or retiring equipment from active service including disposing of hazardous material in an approved way.

Deferral of services: Postponement or denial of weatherization services to the client.

Dehumidification: The removal of water from the air. Excess humidity can cause mold. *Decking:* The wood material structural sheathing installed over the rafters to support the roofing.

Decommissioning: Removing or retiring equipment from active service including disposing of hazardous material in an approved way.

Deferral of services: Postponement or denial of weatherization services to the client.

Dehumidification: The removal of water from the air. Excess humidity can cause mold. *Depressurize:* Cause to have a lower pressure or higher vacuum with respect to a pressure reference point such as the outdoors.

Desiccant: A liquid or solid material used to absorb water or water vapor.

Design temperature: A high or low temperature, based on climate history, used for designing heating and cooling systems when calculating heating and cooling loads.

Desk monitoring: Weatherization monitoring activities performed through review of paperwork.

De-superheater: A heat exchanger that removes the superheat from a compressed refrigerant and transfers that heat to another fluid, usually water.

Dew point: The warmest temperature of an object in an environment where water condensation from the surrounding air would form on that object.

Diffusion: Movement of water vapor through a material as a function of the *vapor pressure* across a material and the vapor permeability of that material. See also: *vapor permeable*

Dilution air: Air that enters through the dilution device—an opening where the chimney joins to an atmospheric-draft combustion appliance

Dilution Device: A draft diverter, draft hood, or barometric draft control between an atmospheric-draft combustion appliance and its chimney.

Direct-vent appliance: A combustion appliance for which all combustion gas is vented to the outdoors through a separate, dedicated supply-air pipe.

Direct current: An electric current flowing in only one direction.

Direct leakage: Air enters and exits at same location.

Discount rate: The interest rate at which expected future cash savings can be discounted for the time value of money.

Distribution system: A system of wires, pipes, or ducts that distributes energy.

DOE: The United States Department of Energy.

Domestic hot water (DHW): Refers to a separate, closed system to heat potable (drinkable) water and supply it to the dwelling unit for washing, bathing, etc.

Dominant duct leakage: To identify either dominant supply or return leaks in a forced-air distribution system by measuring house pressure.

Door casing: A wooden trim around doors that covers the seam between the jamb and the wall.

Door stop: The wood trim fastened to the inside of the door jamb that stops the door's swing.

Dose: The amount of pollutant that enters a human body, exposed to the pollutant.

Dormer: A framed structure projecting above a sloping roof surface, and normally containing a vertical window.

Double-hung window: Double-hung windows have operable upper and lower sashes that slide vertically in a channel.

Downflow: Airflow configuration in a furnace where air flows from above the air handler and discharges from the bottom.

Downflow furnace: Furnace type where the blower is located at the top of the furnace cabinet and air is forced downwards across the heat exchanger and into the ducts located in below the furnace.

Downstream: Away from the source of the flow.

Draft: A pressure difference that causes combustion gases or air to move through a vent connector, flue, chimney, or combustion chamber.

Draft diverter: A device located in gas appliance flue pipe. Used to moderate or divert draft that could extinguish the pilot or interfere with combustion.

Draft fan: A mechanical fan used in a venting system to augment the natural draft in gas- and oil-fired appliances. These electrically operated, paddle-fan devices are installed in furnaces.

Draft gauge: Device for testing chimney draft.

Draft hood: See draft diverter.

Draft inducer: A fan that depressurizes the combustion chamber or venting system to move combustion products toward the out-doors.

Draft regulator: A self-regulating damper attached to a chimney or vent connector for the purpose of controlling draft.

Drainage plane: A space that allows water storage and drainage in a wall cavity, adjacent to or part of the *water-resistive barrier*.

Dropped down belly: Mobile home configuration where a hump is formed in the floor by the rodent barrier and insulation going around the main duct attached to the floor's bottom.

Dropped soffit: A lowered part of the ceiling in a home.

Drywall: Gypsum interior wallboard used to produce a smooth and level interior wall surface and to resist fire. Also called gypsum wall board or sheet rock.

Dry-bulb temperature: Normal ambient air temperature measured by a thermometer.

Duct blower: A blower-door-like device used for testing duct leakiness and airflow.

Duct board: Rigid board composed of insulation material with one or both sides faced with a finishing material, usually aluminum foil.

Decking: The wood material structural sheathing installed over the rafters to support the roofing.

Decommissioning: Removing or retiring equipment from active service including disposing of hazardous material in an approved way.

Deferral of services: Postponement or denial of weatherization services to the client.

Dehumidification: The removal of water from the air. Excess humidity can cause mold.

Duct boot: Transition piece that connects the main duct to the floor and is often vulnerable to failure.

Duct-induced pressure differences: Pressure differences between rooms in a building caused by the ducted air delivery system, can be due to supply ducts, return ducts, or both.

Duplex: Any structure which consists of two separate dwelling units in one building.

Dwelling unit: A house, including a stationary mobile home, an apartment, a group of rooms, or a single room occupied as separate living quarters.

Eave: The part of a roof that projects beyond its supporting walls (See - *Soffit*).

Eave chute: Device that maintains air space between the insulation blanket and the roof sheathing and prevents insulation from clogging eave vents.

Eave vent: Vent opening located in the soffit under the eaves of a house to allow the passage of air through the attic and out the roof vents.

Economizer: A subsystem in an HVAC system that saves energy by using favorable outdoor temperature and humidity to condition building air.

Efficiency: The ratio of output divided by input.

Efficacy: The number of lumens produced by a watt used for lighting a lamp. Used to describe lighting efficiency. Synonym: Effectiveness.

Egress window: A window with a defined opening size for the purpose of fire escape.

Elastomeric: A characteristic of a material that is flexible and permits joint movement.

Elastomeric coating: Polymeric material, such as acrylic, that is used to coat roof leaks and to reduce solar heat gain.

Electrical load: Term for the wattage drawn by a electrical device or the device itself.

Electric service: The electric meter and main switch, usually located outside the building.

Electro-mechanical: Describes controls where an automatic mechanical device like a bi-metal or bulb-and-bellows does the switching.

Emergency heat: 1. A heating device that doesn't require electric-ity used during an emergency. 2. Or electric resistance heating elements used for heating in case a heat pump's compressor fails.

Emittance: The rate that a material emits radiant energy from its surface. Also called emissivity.

Encapsulation: Any covering or coating that acts as a barrier between the hazard, such as lead-based paint, and the indoor environment.

Enclosure: The building shell or building envelope. The exterior walls, floor, and roof assembly of a building.

Energy: A quantity of heat or work

Energy audit: The process of identifying energy conservation opportunities in buildings.

Energy auditor: One who inspects and surveys the energy use of buildings in order to promote energy conservation.

Energy conservation measures (ECM): Building components or products installed to reduce the building's energy consumption.

Energy consumption: The conversion or transformation of potential energy into kinetic energy for heat, light, electricity, etc.

Energy education: Communication used by weatherization staff to inform clients of ways to reduce energy consumption by altering their behavior.

Energy efficiency: Term used to describe how efficiently a build-ing component uses energy.

Energy efficiency ratio (EER): A measurement of energy effi-ciency for room air conditioners. The EER is computed by dividing cooling capacity, measured in British Thermal Units per hour (Btuh), by the watts of electrical power. (See - Seasonal Energy Efficiency Rating or SEER)

Energy factor: The fraction of water heater input remaining in 64 gallons per day of hot water flowing from a water heater.

Energy Information Administration (EIA): Section of the U.S. Department of Energy providing statistics, data, and analysis on resources, supply, production, and consumption for all energy sources.

Energy rater: A person who evaluates the energy efficiency of a home and assigns a performance score, a certification received from HERS (Home Energy Rating System).

Energy-recovery ventilator (ERV): A ventilator that recovers latent and sensible energy from the exhaust air stream and imparts it to the incoming airstream.

Enthalpy: The internal heat of a material measured in Btus per pound.

Entropy: Heat unavailable to a closed thermodynamic system during a heat transfer process.

Envelope: The building shell. The exterior walls, floor, and roof assembly of a building. Also referred to as the enclosure.

Environmentally sensitive: Highly susceptible to adverse effects of pollutants.

EPA, U.S. Environmental Protection Agency: EPA protects human health and safeguards the natural environment.

Equivalent Leakage Area (ELA): Calculation, in square inches, of the total area of all holes and cracks in a structure. The leakage area is then accumulated to represent one total leakage point.

Equivalent length: The length of straight pipe or duct that has equivalent resistance to a pipe fitting or duct fitting. Used for piping and duct design

Equivalent duct length (EDL): A measure of how much static pressure a fan has to overcome.

Equivalent leakage area (ELA): Calculation, in square inches, of the total area of all holes and cracks in a structure. The leakage area is then combined to represent one total leakage area.

Evaporation: The change of a liquid to a gas. Evaporation is the key process in the operation of air conditioners and evaporative coolers. Evaporation absorbs heat.

Evaporative cooler: A device for cooling homes in dry climates by reducing the temperature of incoming air by the evaporation of water.

Evaporator: The heat transfer coil of an air conditioner or heat pump that cools the passing air as the refrigerant inside the coil evaporates and absorbs the air's heat.

Excess air: Air in excess of what is needed for combustion.

Exfiltration: The movement of air out of a building.

Expanded polystyrene: White polystyrene insulation.

Expanding foam: An insulation product designed to expand and harden upon contact with the air. Available in canisters with spray nozzles that make it easy to apply foam in a wide variety of situations.

Expansion valve: A valve that meters refrigerant into the evaporator.

Exposure: A specific assessment of pollutant amount and duration that a human is exposed to.

Fahrenheit: A temperature scale used in the United States and a few other countries. On the Fahrenheit scale, water boils at 212 degrees and freezes at 32 degrees.

Fan-assisted combustion: A combustion appliance with an integral fan to draw combustion supply air through the combustion chamber.

Fan control: A bi-metal thermostat that turns the furnace blower on and off as it senses the presence of heat.

Fan-off temperature: In a furnace, the supply-air temperature at which the fan control shuts down the blower fan.

Fan-on temperature: In a furnace, the supply air temperature at which the fan control activates the blower fan.

Federal Energy Management Program (FEMP): A program of DOE that implements energy legislation and presidential directives. FEMP provides project financing, technical guidance and assistance, coordination and reporting, and new initiatives for the federal government.

Feeder wires: The wires connecting the electric meter and main switch with the main panel box indoors.

Fenestration: Window and door openings in a building's wall.

Fiberglass: A fibrous material made by spinning molten glass used as an insulator and heat loss retardant.

Field testing: Evaluation of a trainee's abilities conducted on-site, rather than in a classroom.

Fill tube: A plastic or metal tube used to blow insulation inside a building cavity.
Fire barrier: A fire-resistance-rated building assembly, designed to contain a fire for a particular time period.

Final inspection: An evaluation of a weatherization job at or after its completion.

Finished attic: An attic that was converted to living space by the construction of dormers and knee walls.

Fire blocking: Building materials installed to resist the free passage of flames and smoke, to adjacent areas of the building.

Fire resistance: The property of building materials or assemblies that prevents or retards the passage of heat, hot gases, or flames during a fire.

Fire resistance rating: The period of time a building element, component or assembly maintains the ability to confine a fire, continues to perform a given structural function, or both.

Fire stop: Framing member designed to stop the spread of fire within a wall cavity.

Firewall: A fire-resistance-rated smoke-tight wall with protected openings that restricts the spread of fire. A firewall extends continuously from the foundation to or through the roof. The fire-wall is designed to remain standing even if the assemblies on either side collapse during a fire.

Flame impingement: The contact of flame against an object, such as a metal heat exchanger.

Flame-retention head burner: A high efficiency oil burner that produces a hotter flame and operates with a lower airflow, compared to older oil burners.

Flame roll-out: Fuel gas combustion process occurring outside the normal combustion area of a combustion appliance.

Flame safety control: A control device used to stop the flow of fuel to the burner if the fuel doesn't ignite.

Flame spread: A fire rating for materials in a fire test that compares the spread of flame to red oak, which has a flame spread of 100.

Flammability: The rating for building materials that will burn readily when exposed to a flame.

Flammable: Combustible; readily set on fire.

Flashing: Waterproof material used to prevent leakage at intersections between building assemblies or penetrations through the building envelope.

Floor joists: The framing members that support the floor.

Flue: The channel or pipe that conveys combustion gases.

Flue gas: Combustion gases, mainly carbon dioxide, water vapor, nitrogen, and oxygen.

Flush flange: A window frame designed to provide a finished exterior appearance over a flat exterior surface like stucco.

Foam board: Plastic foam insulation manufactured most commonly in sheets.

Foam compatible adhesive: Adhesive that is manufactured to safely adhere foam to itself and other materials.

Foot candle: A measure of light striking a surface.

Footing: The part of a foundation system that actually transfers the weight of the building to the ground.

Forced draft: A vent system for which a fan installed at the combustion appliance moves combustion gases to the outdoors with positive static pressure in the vent pipe. Because of this positive pressure, the vent connector must be air-tight.

Fouling: The deposit of particles and fluids on a heat exchanger or other HVAC component.

Friable: Easily broken into small fragments or reduced to powder, as with asbestos.

Frost line: The maximum depth of the soil where water will freeze during the coldest weather.

Fuel escalation rate: Annual escalation rate of fuel prices based on the annual energy price forecasts of DOE's Energy Information Administration.

Furnace: An appliance that produces and distributes warm air throughout the dwelling unit.

Furring: Thin wood strips fastened to a wall or ceiling surface as a nailing base for finish materials.

Fuse: A current carrying element that melts if too much current flows in an electric circuit.

Gable: The triangular section of an end wall formed by the pitch of the roof.

Gable roof: A roof shape that has a ridge at the center and slopes in two directions.

Gable vent: A screened vent installed at or near the peak of a roof gable that allows air exchange between the attic and outdoors.

Gallons per minute (GPM): The unit for measuring water flow in a supply pipe or heat-distribution pipe or oil flow in a burner.

Gasket: Elastic strip that seals a joint between two materials.

General heat waste: Pertaining to general weatherization materials that DOE believes are cost-effective.

Glare: Any bright light or light reflection that annoys, distracts, or reduces visibility.

Glass load factor: A number combining glass's solar heat transmission and its heat conduction. Used for cooling load calculations.

Glazing: Pertaining to glass assemblies, installation or windows.

Glazing compound: A flexible, putty-like material used to seal glass in its sash or frame.

Grade: The level of the ground around a building.

Grantee: The individual or organization that receives a grant.

Gravity furnace: A central heating system that uses natural gravity to distribute heated air or water throughout the dwelling unit as opposed to forced circulation, using pumps or blowers.

Ground fault circuit interrupter (GFI or GFCI): An electrical connection device that breaks a circuit if current flows in a grounding wire.

Ground-moisture barrier: A plastic material covering the ground that is both a vapor barrier and a water barrier, which protects building materials from excessive relative humidity.

Gusset: A metal or wood plate added to the surface of a joint to strengthen the connection.

Gypsum board: A common interior sheeting material for walls and ceilings made of gypsum rock powder packaged between two sheets of heavy building paper. Also called drywall, sheet-rock, gyprock, or gypboard.

Habitable space: A building space intended for continual human occupancy. Examples include areas used for sleeping, dining, and cooking, but not bathrooms, toilets, hallways, storage areas, closets, or utility rooms. See occupiable space and conditioned space.

Hallway return or hallway return system: A type of mobile home air distribution system. The mobile home heating or cooling system receives return air through a central trunk line beneath the hallway.

Hatch: A rectangular hole in a horizontal building assembly like a floor or ceiling that allows access

Hazardous Material: A particular substance that is considered a danger to the client or crew.

Head: Foot pounds of mechanical energy per pound of fluid created by a pump to overcome gravity or friction.

Head jamb: Groove at the top of the window that allows the window sashes to slide into place and sit inside the window frame.

Health and safety (H&S): Provision included in a 1976 law change for the Weatherization Assistance Program. WAP now considers the health and safety of low-income families, as well as reducing their energy costs.

Heat: Molecular movement

Heat anticipator: A device in a thermostat that causes the thermostat to turn off before room temperature reaches the thermostat setting, so that the house doesn't overheat from heat remaining in the heater and distribution system after the burner shuts off.

Heat capacity: The quantity of heat required to raise the temperature of 1 cubic foot of a material 1 degree F.

Heat exchanger: The device in a heating unit that separates the combustion chamber from the distribution medium and transfers heat from the combustion process to the distribution medium.

Heat gains: Term used to mean unwanted heat that accumulates in homes, making mechanical cooling desirable or necessary.

Heat loss: The amount of heat escaping through the building shell as measured for a specific period of time (month, year, etc.)

Heat pump: A type of heating/cooling unit, usually electric, that uses a refrigeration system to heat and cool a dwelling.

Heat-recovery ventilator: A central ventilator that transfers heat from exhaust to intake air.

Heat transmission: Heat flow through the walls, floor, and ceiling of a building, not including air leakage.

Heat transfer coefficient: See U-factor.

Heating degree day(s) (HDD): See: Degree days

Heating load: The maximum rate of heat conversion needed by a building during the coldest weather.

Heating seasonal performance factor (HSPF): Rating for heat pumps describing how many Btus of heat they transfer per watt-hour of electricity they consume.

High-efficiency particulate air (HEPA) vacuum: A vacuum cleaner that uses a high-efficiency particulate air (HEPA) filter.

High limit: A thermostat that turns the heating element of a furnace or boiler off if it senses a dangerously high temperature.

Hinges: The metal objects that attach a door to a door jamb, normally with screws.

Hip roof: A roof with two or more adjacent roof surfaces, joined along a sloping “hip.”

Home energy index: The number of BTUs or kWh of energy used by a home, divided by its area of conditioned square feet.

Home energy rating systems (HERS): A nationally recognized energy rating program that give builders, mortgage lenders, secondary lending markets, homeowners, sellers, and buyers a precise evaluation of energy losing deficiencies in homes.

Home heating index: The number of Btus of energy used by a home divided by its area in square feet, then divided by the number of heating degree days during the time period.

HOME Program: A program created under Title II (the Home Investment Partnership Act) of the National Affordable Housing Act of 1990. Provides funds for states to expand the supply of decent and affordable housing for low-income people.

Home Ventilating Institute (HVI): A non-profit association of manufacturers of residential ventilating products offering a variety of services including testing, certification, verification, and marketing programs.

Hot roof: An unventilated roof with insufficient insulation to prevent snow melting on the roof and the creation of ice dams.

House as a system: The concept that many components of a house interact, affecting the home's comfort and performance.

House depressurization limit: A selected indoor negative pressure; expressed in Pascals, immediately around vented combustion appliances that use indoor air for combustion supply air.

House pressure: The difference in pressure between the indoors and outdoors measured by a manometer.

House wrap: A generic term for the modern version of the building's water-resistive barrier.

HUD: U.S. Department of Urban Housing and Development

Humidistat: An automatic control that switches a fan, humidifier, or dehumidifier on and off to control relative humidity.

Humidity ratio: Same as "absolute humidity." The absolute amount of air's humidity measured in pounds or grains of water vapor per pound of dry air.

HVAC: Heating, ventilation, and air-conditioning system. All components of the appliances used to condition a building's indoor air.

Hydronic system: A heating system that uses hot water or steam as the heat-transfer fluid. Commonly called a hot-water heating system.

Hygrometer: A tool for measuring relative humidity. A psychrometer, which uses two thermometers, one with a dry bulb and one with a wet bulb, is a simple hygrometer.

IAQ: Indoor Air Quality. The quality of indoor air relative to its acceptability for healthful human habitation.

I-beam: A rolled or extruded metal beam having a cross section resembling a capital I.

IC rated: Insulation Contact rating for light fixtures. IC housings may be in direct contact with fibrous insulation.

Ice dam: Ice that forms at the roof eaves during differential temperatures of a roof deck causing freezing and thawing.

IECC: International Energy Conservation Code

Ignition barrier: A material installed to prevent another material, often plastic foam, from catching fire.

Illumination: The light level measured on a horizontal plane in Foot Candles.

Inaccessible cavity: An area that is too confined to enter and/or maneuver in by an average worker.

Incandescent light: The common light bulb found in residential lamps and light fixtures and known for its inefficiency.

Inches of Water Column (IWC): A non-metric unit of pressure difference. One IWC equals about 250 Pascals.

Incidental repairs: Under DOE rules, this term refers to the repairs on a dwelling unit to protect the performance and durability of *energy conservation measures*.

Indirect leakage: Describes how air leaks into the home at one point and out at a different point. Indirect leakage is more difficult to discover compared to direct leakage. Indirect leakage occurs through a dwelling's *bypasses* or *chaseways*.

Indoor air quality (IAQ): The quality of indoor air relative to its acceptability for healthful human habitation.

Induced draft: A vent system or combustion appliance for which a fan, installed at or very near the termination point of the appliance or the vent pipe, moves the combustion gases.

Infiltration: Infiltration refers to the movement of air into a building through cracks and penetrations in the building envelope.

Infrared: Pertaining to heat rays emitted by the sun or warm objects on earth.

Infrared camera: A special camera that “sees” temperature differences on surfaces, allowing the user to determine if a building assembly is insulated properly. This instrument is also useful for detecting air leakage if used with a blower door.

Infrared thermography: The science of using infrared imagers to detect radiant energy on building surfaces, which visualizes a building’s heat loss.

Input rating: The measured or assumed rate at which an energy-using device consumes electricity or fossil fuel.

Insolation: The amount of solar radiation striking a surface.

Inspector: A weatherization worker responsible for quality control or quality assurance by making final inspections and in-progress inspections.

Inspection gap: A gap in foundation insulation left for the purpose of inspecting for insect infestation.

Instantaneous water heater: A water heater with no storage tank that heats water instantaneously as the water flows through it.

Insulated flex duct: A round duct composed of two flexible plastic tubes with tubular insulation and air barrier between the two.

Insulated glass: Two or more glass panes spaced apart and sealed in a factory.

Insulation: A material used to resist heat transmission.

Insulation dam: A material that prevents fibrous insulation from flowing into an area where it isn’t necessary or wanted.

Insulation restrainer: A flexible material, such as netting or fabric, use to hold blown fibrous insulation in place.

Insulation shield: A fire-barrier erected around a heat producing device to prevent insulation from covering or contacting hot surfaces.

Insulated glass unit (IGU): Two or more glass panes spaced apart and sealed in a factory.

Intentionally conditioned: Conditioned by design and fitted with radiators, registers, or other devices to maintain a comfortable temperature.

Intermediate zone: A zone located between the building's conditioned space and the outdoors, like a crawl space or attic.

Intermittent ignition device (IID): A device that lights the burner on a gas appliance when the control system calls for heat, thus saving the energy wasted by a pilot light.

Internal gains: The heat generated by bathing, cooking, and operating appliances, that must be removed during the summer to promote comfort.

International Association of Plumbing and Mechanical Officials (IAPMO): The industry trade group that develops the Uniform Mechanical Code and the Uniform Plumbing Code.

International Codes Council (ICC): An international non-governmental organization for developing building safety, fire prevention, and energy efficiency codes (I-codes).

International Fuel Gas Code (IFGC): Code that addresses the design and installation of fuel gas systems and gas-fired appliances through requirements that emphasize performance.

International Residential Code (IRC): The most prominent building code in the US managed by the *International Codes Council*.

Interstitial Space: Building cavity. Space between framing and other building components.

Intrusion: Air moving into and out of insulation without going through the wall or ceiling assembly.

Jalousie windows: A type of window usually associated with mobile homes with two or more panes of glass that pivot on a horizontal axis.

Jamb: The side or top piece of a window or door frame.

Jamb clips or plates: Structural devices used to fasten a block-frame window to its opening.

Job task analysis: A prioritized list of knowledge, skills, and abilities derived from analysis of a job.

Joist: A horizontal wood framing member that supports a floor or ceiling.

Joule: A unit of energy. One thousand joules equals 1 BTU.

Kerf: A slit made by cutting, often with a saw.

Kilowatt: A unit of electric power equal to 1000 joules per second or 3412 Btus per hour.

Kilowatt-hour: The most commonly used unit for measuring the amount of electricity consumed over time; one kilowatt of electricity supplied for one hour. A unit of electric energy equal to 3600 kilojoules.

Knee wall: A short wall, often less than three feet in height. Knee walls are common in old houses with finished attic spaces.

Knee-wall attic: An triangular attic with short walls, usually under three feet in height.

Knob-and-tube wiring: Early standardized electrical wiring in homes consisting of insulated copper conductors supported by porcelain knobs and tubes.

Lamp: A light bulb.

Latent heat: The amount of heat energy required to change the state of a substance between a solid and a liquid, or from a liquid to a gas.

Lath: A support for plaster, consisting of thin strips of wood, metal mesh, or gypsum board.

Lawrence Berkeley National Laboratory (LBNL): Member of the national laboratory system supported by DOE through its Office of Science. LBNL conducts research on building energy efficiency.

Lead-Safe Work Practices (LSW): Work practices required by DOE for pre-1978 homes when the weatherization work will disturb more than 2 square feet of painted surface in an interior room, 10 percent of a small component such as a baseboard or door casing, and/or when the work will disturb more than twenty square feet of painted exterior surface.

Leadership in Energy and Environmental Design (LEED): A building certification system developed by the U.S. Green Building Council.

Leakage ratio: Measurement of total square inches of air leakage area per 100 feet of building envelope surface area.

Light quality: The relative presence or absence of glare and brightness contrast. Good light quality has no glare and low brightness contrast.

Local ventilation: Ventilation at the source of building pollutants, also called *spot ventilation*. For example: kitchen and bathroom exhaust fans.

Loose-fill insulation: Fibrous insulation in small fibers that installers blow into a building assembly using a blowing machine.

Low-flow rings: Part of a blower door that forces air past the sensors fast enough to obtain a reliable reading.

Low-E: Short for “low emissivity”, which means the characteristic of a metallic glass coating to resist the flow of radiant heat.

Low expanding foam: Liquid-applied form that expands 20-30 times its liquid size.

Low water cutoff: A float-operated control to turn the burner off if a steam boiler is low on water.

Lumen: A unit of light output from a lamp.

Luminaire: A light fixture.

Main panel box: The electric service box containing a main switch, and the fuses or circuit breakers located inside the home.

Make-up air: Air supplied to a space to replace exhausted air.

Manifold: A tube with one inlet and multiple outlets, or multiple inlets and one outlet.

Manometer: A differential gauge used for measuring pressure.

Manufactured homes: Transportable homes that are faster and less expensive to build compared to site-built homes.

Mastic: A thick creamy substance used to seal seams and cracks in building materials, especially ducts.

Masonry: Stone, brick, or concrete block construction.

Materials safety data sheet (SDS): A sheet containing data regarding the properties of a particular substance, intended to provide workers with procedures for handling or working with that substance in a safe manner, including information such as physical data, toxicity, health effects, first aid, storage, disposal, and protective equipment.

Mean radiant temperature (MRT): The area-weighted mean temperature of all the objects in an environment.

Mechanical draft: A combustion appliance with induced draft of forced draft.

Meeting rails: The rail of each sash that meets a rail of the other when the window is closed.

Membrane: A barrier that separates two environments. Membranes may be permeable to the flow of air, water, and other fluids or particles.

Microclimate: A very localized climatic area, usually a small site or habitat.

Micron: A micrometer or 1/100,000 of a meter.

Mildew: Fungi that colonize organic building materials.

Minimum Efficiency Rating Value (MERV): The dominant industry rating of the ability of HVAC air filters to remove particles.

Mitigate: To make better or reduce some negative effect.

Mobile home belly: Part of a home that contains the insulation, duct system, and plumbing. It is enclosed by the sub- and finished floor, with a rodent barrier underneath.

Mobile Home Energy Audit (MHEA): A software tool that predicts manufactured home energy consumption and recommends weatherization retrofit measures.

Moisture meter: An instrument for measuring the percentage of water in a substance.

Mold: A growth of minute fungi forming on vegetable or animal matter and associated with decay or dampness.

Monitor: The process through which a person, frequently a representative of a State or Federal agency, visits completed units to ensure that weatherization funding is spent appropriately.

Mortar: A mixture of sand, water, and cement used to bond bricks, stones, or blocks together.

Mortise: A recessed area cut into the wood framing member where a hinge or wood tongue fits.

SDS: Materials Safety Data Sheet.

Mud sill: A wood component attached to the foundation of a building that creates a means of attaching various components of the framing to the foundation.

Mullion: Vertical framing members that don't run the full length of the door.

Multifamily (MF) housing: A building with five or more residential units.

Mushroom vent: A vent that has at the top of a vertical shaft a broad rounded cap that can be screwed down to close it.

Nail fin or flange: Semi-flexible strips of metal or plastic used to attach a window frame to the outside of a rough opening.

National Association for State Community Services Programs (NASCSPP): Assists States in responding to poverty issues. NASCSPP members are state administrators of the Community Services Block Grant (CSBG) and U.S. Department of Energy's Weatherization Assistance Program (DOE/WAP).

National Electric Code (NEC): A safety code regulating the electricity use. The NEC is a product of the National Fire Protection Association.

National Energy Audit Tool (NEAT): Created by Oak Ridge National Laboratories as a DOE approved audit qualifying for the 40% materials waiver. It is a computerized auditing tool for prioritizing energy conservation measures for houses.

National Fenestration Rating Council (NFRC): NFRC is a non-profit organization that administers the only uniform, independent rating and labeling system for the energy performance of windows, doors, skylights, and attachment products.

National Fire Protection Association (NFPA): Creates and maintains minimum standards and requirements for fire prevention, training, and equipment, developing and publishing codes and standards such as the NFPA 70, the National Electric Code, and NFPA 54, the National Fuel Gas Code.

National Institute for Occupational Safety and Health (NIOSH): A federal agency responsible for conducting research and making recommendations for the prevention of work-related injury and illness to help ensure safe and healthful working conditions.

Natural draft: Draft that relies on the buoyancy of heated gases (not a fan) to move combustion gases up a chimney.

Natural gas: A hydrocarbon gas that is usually obtained from underground sources, often in association with petroleum and coal deposits.

Natural ventilation: Ventilation using only natural air movement without fans.

Net-free vent area (NFVA): The area of a vent after that area has been adjusted for insect screen, louvers, and weather covering. The free area is always less than the actual area.

Netting: An open weave fabric or plastic mesh that supports fibrous insulation. See *insulation restrainer*

NFPA: National Fire Protection Association.

NFPA 211: National Fire Protection Association's Standard for Chimneys, Fireplaces, Vents, and Solid-Fuel-Burning Appliances includes installation procedures for vents and chimneys that serve wood-burning stoves and fireplaces.

NFPA 31: National Fire Protection Association's Standard for the Implementation of Oil-Burning Equipment, dictating that chimneys must be at least 2 feet higher than any portion of the building within 10 feet.

NFPA 54: National Fire Protection Association's National Fuel Gas Code.

Noncombustible material: Materials that pass the test procedure for defining noncombustibility of elementary materials set forth in ASTM E 136.

Nonconditioned space: A space that isn't heated or cooled.

Non-expanding foam: Spray foam that doesn't expand. Used in window and door jambs, and other constricted spaces where expanding foam may distort building window or door frames.

Nozzle: An orifice for spraying a liquid like fuel oil.

O₂: Oxygen

Oak Ridge National Laboratory (ORNL): Laboratory where the Mobile Home Energy Audit (MHEA) software was developed.

Occupants: People of any age living in a dwelling. Animals are not defined as occupants.

Occupational Safety and Health Administration (OSHA): An agency of the United States Department of Labor, with a mission

to prevent work-related injuries, illnesses, and occupational fatalities by issuing and enforcing standards for workplace safety and health.

Off-gas: Off-gassing is the evaporation of volatile chemicals in non-metallic materials at normal atmospheric pressure. This means that building materials can release chemicals into the air through evaporation.

Ohm: A unit of measure of electrical resistance. One volt can produce a current of one ampere through a resistance of one ohm.

One-part foam: One-part foam comes in spray cans (e.g., Great Stuff) and spray guns with screw-on cans. One-part foam is best suited for filling gaps and holes less than $\frac{3}{4}$ -inch.

Open-combustion appliance: An appliance that does not have a sealed combustion chamber and draws its combustion air from the surrounding room.

Orifice: A hole in a gas pipe or nozzle fitting where gas or fuel oil exits to be mixed with air before combustion occurs in the heating chamber. The diameter of the orifice determines the flow rate.

Orphaned water heater: A gas water heater that formerly shared a chimney with a gas furnace or boiler but now is the only appliance venting into the naturally drafting chimney.

Oscillating fan: A fan, usually portable, that moves back and forth as it operates, changing the direction of the air movement.

OSHA : Occupational Safety and Health Administration

Output capacity: The useful heat in BTUH that a heating unit produces after accounting for waste.

Over-fired: When a burner burns too much fuel caused by oversized fuel nozzles or excessive fuel pressure.

Oxidation: The chemical reaction of a substance with oxygen.

Oxygen content: A measure of the amount of oxygen in the air or combustion gases as a percent.

Oxygen-depletion sensor: A safety device on a heating unit that shuts off the fuel supply when oxygen content of the combustion air is inadequate.

Packaged air conditioner: An air conditioner that contains the compressor, evaporator, condenser, and air handler in a single cabinet.

Packaged terminal (PT): A self-contained space heating and/or cooling system, usually powered with electricity, .

Packaged terminal air conditioner or heat pump (PTAC or PTHP): A self-contained space heating and/or cooling system, frequently installed in a sleeve through the exterior wall of a building, using heat pump technology. Common in hotels and apartment buildings.

Panel: Parts of a door between rails and stiles or mullions.

Parapet walls: A low wall at the edge of a low-sloping roof.

Parts per million (ppm): The unit commonly used to represent the degree of pollutant concentration, where the concentrations are small.

Pascal (Pa): A unit of measurement of air pressure. One inch of water column equals 247 pascals. Atmospheric pressure (29.92 inches of mercury) is equivalent to 102,000 Pa.

Passive attic venting: Takes advantage of the natural buoyancy of air by providing inlets and outlets low and high on the roof.

Payback period: The number of years that an investment in energy conservation requires to repay its cost through energy savings.

Performance standard: Specification of the conditions that exist when a someone performs a job in an approved manner.

Perimeter basement drain: An indoor drain cut into the floor and around the perimeter of a basement or crawl space to intercept and remove water from the basement.

Perlite: A heat-expanded non-combustible mineral used for insulation.

Perm: A measurement of how much water vapor a material transmits per hour. Specifically: diffusion of 1 grain of water vapor per hour, per square foot, per inch of mercury pressure.

Permeance rating: Number that quantifies the rate of vapor diffusion through a material.

Personal fall arrest system: A system used to arrest an employee in a fall from a working level. It consists of an anchor point, connectors, a body belt or body harness and may include a lanyard, deceleration device, lifeline, or combinations of these.

Personal protective equipment (PPE): Accessories such as safety glasses, ear plugs, and respirators worn to protect individuals from workplace hazards.

Phase change: The act of changing from one state of matter to another, for example: solid to liquid or liquid to gas.

Photoresistor: Electronic sensing device used to sense flame, sunlight, artificial light.

Photovoltaic (PV): A solid-state electronic device that converts light into direct current electricity.

PIC: Polyisocyanurate foam insulation.

Picture window: Picture windows have no operable sashes and are used primarily for outdoor viewing and daylighting.

Pier and beam foundation: Housing base that uses a concrete footing and a pier to support the floor, walls, and roof.

Pitch: The slope of a roof expressed as the rise over the run or by an angle in degrees.

Plaster: A plastic mixture of sand, lime, and Portland cement spread over wood or metal lath to form the interior surfaces of walls and ceilings.

Plastic tie band: A ratcheting plastic band used to clamp wires or flexible ducts to metal ducts or to attach insulation to round metal ducts.

Plate: A framing member installed horizontally to which the vertical studs in a wall frame are attached.

Platform framing: A system of framing a building in which floor joists of each story rest on the top plates of the story below or on the foundation sill for the first story, and the bearing walls and partitions rest on the subfloor of each story.

Plenum: The large duct that connects the air handler to the main ducts.

Plumb: Absolutely vertical at a right angle to the earth's surface.

Plywood: Laminated wood sheeting with layers cross-grained to each other.

PM: Particulate matter or particle pollution. PM_{2.5} particles are less than 2.5 microns in diameter. PM_{10-2.5} are between 2.5 and 10 microns in diameter.

Pocket doors: Doors that slide into a wall cavity and typically leak a lot of air.

Polyethylene: A plastic made by the polymerization of ethylene, used in making, lightweight, and tough plastics, films, insulations, and vapor barriers.

Polyisocyanurate (PIC): A plastic foam insulation sold in sheets, similar in composition to polyurethane.

Polystyrene insulation: A rigid plastic foam insulation, usually white, pink, green, or blue in color.

Polyurethane: A versatile plastic spray-foam insulation, usually yellow in color.

Porosity: Measure of the void spaces in a material, expressed as either a fraction or a percentage of the total volume of material.

Positive-pressure, supplied-air respirator: Has its own air compressor to supply fresh air to the worker through a sealed mask or hood.

Potential energy: Energy in a stored form, like fuel oil, coal, wood, or water stored in a reservoir.

Potentiometer: A variable resistor used as a controller or sensor.

Pounds per square inch (psi): Units of measure for the pressure a gas or liquid exerts on the walls of its container.

Power burner: A burner that moves combustion air at a pressure greater than atmospheric pressure. Most oil-fired burners and many larger gas burners are power burners.

Power venter: A blower located on the inside or outside of an exterior wall that pulls the combustion gases out of the appliance and exhausts these gases outdoors.

Prescriptive standard: Specifies in detail the requirements and procedures to be followed rather than specifying a performance outcome.

Present value (PV): The amount that a future sum of money is worth today considering a specific *discount rate*.

Pressure: A force encouraging movement of a fluid by virtue of a difference in density, elevation, or some other condition between two places.

Pressure-and-temperature relief valve: A safety component required on boilers and water heaters, designed to relieve excess pressure or temperature in the tank by discharging water.

Pressure balancing: To equalize house or duct pressure by adjusting supply and return airflow in ducted forced-air distribution systems.

Pressure boundary: The surface that separates indoor air from outdoor air. Also called the air barrier.

Pressure diagnostics: The evaluation of building pressures and airflows in order to control air leakage and to ensure sufficient airflow for heating, cooling, and ventilation.

Pressure-equalized rain screen: A space between the water-resistive barrier and the exterior cladding in a wall that connects to the outdoors so that no pressure difference exists between the space and the outdoors. This assembly gives superior resistance to wind and wind-driven rain.

Pressure-pan testing: One method for determining duct leakage. Uses a pressure pan, manometer, and a blower door to quantify pressure differences and verify improvements after duct sealing.

Pressuretrol: A control that turns a steam boiler's burner on and off as steam pressure changes.

Pressure-reducing valve: An adjustable valve that reduces the building's water pressure to provide water to hydronic and steam heating systems and potable-water systems.

Primary air: Air mixed with fuel before combustion.

Prime window: The main window installed in the rough opening consisting of fixed or moveable sashes (not to be confused with a storm window).

Priority list: The list or ranking of energy-conservation measures developed by a program to produce the most cost-effective energy savings results based on a savings to investment ratio calculation.

Propane (liquefied petroleum gas, or LPG): A colorless, flammable gas occurring in petroleum and natural gas.

Psychrometer: An instrument for determining atmospheric humidity by the reading of two thermometers, the bulb of one being kept moist and ventilated.

Psychrometric chart: A chart presenting the physical and thermal properties of moist air in graphical form. Used in conjunction with a psychrometer to determine relative humidity, dew point, enthalpy, and other characteristics of humid air.

Psychrometrics: The study of the relationship between air, water vapor, and heat.

Pull-down stairs: Staircase that folds up into the attic until pulled down for use.

Pulley seals: A component of a double-hung window sash that minimizes air leakage through the pulley hole.

Purlins: Framing members that sit on top of rafters, perpendicular to them, designed to spread support to roofing materials.

Quality assurance (QA): The systematic evaluation of a product or service to ensure quality standards are being met.

Quality control (QC): Review of the final work product to ensure that it was correctly done.

QCI or Quality control inspection: Detailed inspection of the final work product and its relationship to the energy audit and work order.

R-Value: A measurement of thermal resistance of materials, especially layered materials.

Radiant barrier: A metalized sheet or coating designed to reflect radiant heat or to resist the emission of radiant heat.

Radiant temperature: The surface temperature of objects in a home, like walls, ceiling, floor, and furniture.

Radiation: Heat energy that is transferred by electromagnetic energy or infrared light, from one object to another. Radiant heat can travel through a vacuum, through air, or through other transparent and translucent materials.

Radon: A carcinogenic radioactive gas that decomposes into radioactive particles.

Rafter: A roof support that supports the roof deck and follows the roof's slope.

Rain screen: The combination of a water-resistive barrier and a space, used to keep wall assemblies dry in climates with substantial rainfall.

Rater: A person who performs energy ratings. Same as *energy rater*.

Recovery efficiency: A water heater's efficiency at actually heating water to the water heater's rated capacity without considering standby or distribution losses.

Reflectance: The ratio of lamination or radiant heat reflected from a given surface to the total radiation falling on the surface. Also called reflectivity.

Reflective glass: Glass that has a mirror-like coating on its exterior surface to reflect solar heat. The solar heat gain coefficient of reflective glass ranges from 0.10 to 0.30.

Refrigerant: Any of various liquids that vaporize at a low temperature, used in refrigeration systems.

Refrigerant: A fluid used in air conditioners and heat pumps that heats air when it condenses from a gas to a liquid and cools air when it evaporates from a liquid to a gas.

Register: The grille cover over a duct outlet for forced-air distribution systems and may control the airflow.

Relamping: The replacement of an existing, standard light bulbs with lower wattage energy-efficient bulbs.

Relative humidity: The percent of water vapor that air contains, compared to the maximum amount of water vapor the air can hold. Air that is completely saturated has 100% relative humidity.

Relay: An automatic, electrically-operated switch.

Reset controller: Adjusts fluid temperature or pressure in a HVAC system according to the outdoor air temperature.

Residential Load Calculation: Manual J: Allows the user to properly size building HVAC systems.

Resistance: The property of a material resisting the flow of electrical energy or heat energy.

Respirable: Able to be breathed deeply into human lungs.

Retrofit: An energy conservation measure applied to an existing building.

Return air: Air circulating back to an *air handler* from the building, to be heated or cooled and supplied back to the building's conditioned areas.

Return plenum: A large main duct that brings *return air* back to the *air handler*.

Revolutions per minute: Number of times the crankshaft of an combustion engine, or the shaft of an electric motor, rotates in one minute.

Reweatherized unit: Any unit that received weatherization services prior to September 30, 1994 and has received additional services under subsequent grants or allowed by current DOE regulations.

Ridge venting: Ridge venting is a continuous vent (or two strips of vents) along the roof ridge. Usually combined with continuous *soffit* or eave vents as part of an overall attic-ventilation system.

Rim joist: The outermost joist around the perimeter of the floor framing. Also known as band joist.

Riser: Transition piece that connects the main duct to the floor and is often vulnerable to failure. Also the vertical part of a stair step. See also *duct boot*.

Rodent barrier: Guard used to keep rodents from entering a mobile home through its belly.

Roof jack: Chimney assembly that penetrates the roof and includes the flashing and chimney cap assemblies.

Roof vent: A screened and louvered opening to allow air exchange between the attic and outdoors.

Room air conditioner: An small air conditioning unit installed through a wall or window, which cools a room by removing heat and releasing it outdoors.

Room heater: A heater located within a room and used to heat that room.

Rough opening: The framed opening in a wall into which a door or window is installed.

Safety glass: Glass that is toughened or laminated so that it is less likely to splinter when broken.

Sash: A movable or stationary part of a window that frames the glass.

Saturation: Describing a mixture of vapor and liquid at the *phase-change* point. The condition in which the air can't hold any more moisture, as a function of temperature and *vapor pressure*.

Savings-to-investment ratio (SIR): SIR is the cash savings divided by the initial investment over the lifespan of energy-conservation measures. SIRs of greater than one are considered cost effective according to DOE WAP.

Scale: Dissolved minerals that precipitate inside boilers and storage tanks.

Sealed-combustion heater: A heater that draws air for combustion from outdoors and has a sealed exhaust system. Also called a *direct-vent* appliance.

Seasonal efficiency: Refers to the overall efficiency of the central heating system including AFUE and distribution losses.

Seasonal energy efficiency ratio (SEER): A measurement of energy efficiency for central air conditioners. The SEER is computed by dividing cooling capacity, measured in BTUh, by the Watts (see also *Energy Efficiency Rating*).

Seasonal heating performance factor (SHPF): Ratio of useful heat output of a heat pump to the electricity input, averaged over a heating season.

Secondary air: Combustion air surrounding a flame.

Sensible heat: The heat required to change the temperature of a material.

Sequencer: A bimetal switch that turns on the elements of an electric furnace in sequence.

Service equipment: The electric meter and main switch, usually located outside the building.

Service wires: The wires coming from the utility transformer to the service equipment of the building.

Set-point: The temperature setting of a thermostat or other temperature-based control.

Shading coefficient (SC): A decimal describing how much solar energy is transmitted through a window opening compared to clear single glass having an SC of 1.0. For example, reflective glass has an SC of 0.20 to 0.40.

Sheathing: Structural sheeting, attached on top of the framing, underneath the siding and roofing of a building. Any structural building material used for covering a building surface.

Sheet Metal and Air Conditioning Contractors' National Association (SMACNA): An international association of contractors who specialize in heating, ventilation and air conditioning.

Sheeting: Common term for any building material used for covering a building surface.

Sheetrock: See *drywall*.

Shell: The building's exterior envelope including walls, floor, and roof.

Shingle: A modular waterproof roofing material, that installs in overlapping rows to cover the roof surface.

Short circuit: A dangerous malfunction in an electrical circuit where electricity flows through conductors and into the ground without going through an *electrical load*.

Sill: The bottom of a window or door frame.

Sill box: The outer area of the floor bound by the *rim joist*, floor joist, sill plate, and floor.

Sill pan: A flashing device that sits on a rough-framed window sill to prevent water penetration if water infiltrates the cladding and sealant around the finished window.

Single-family (SF) home: A free-standing residential building, occupied by one family unit.

SIR: See *savings-to-investment ratio*.

Skirting: A non-structural screening built around the exterior of an open crawl space to exclude animals, wind, and sunlight. Also has aesthetic value.

Slab-on-grade foundation: Building foundation using a concrete slab usually poured at one time.

Slider window: A slider window is essentially a double-hung window turned on its side so the sashes move horizontally.

Sling psychrometer: A device holding two thermometers that is slung through the air to measure wet-bulb temperature and dry-bulb temperature for calculating relative humidity, enthalpy, and other *psychrometric* factors.

Slope: The roof section of an attic with the roof and ceiling surfaces attached to the rafters. See also: *pitch*.

Smoke-developed index: The level of smoke that a material produces when burning in a fire test compared to red oak, which has an index of 100.

Smoke tester: Device to test the amount of smoke being produced by an oil-burning furnace or boiler. High smoke means the fuel-to-air ratio is incorrect, and combustion is inefficient.

Soffit: The underside of a roof overhang or a small lowered ceiling, as above cabinets or a bathtub.

Solar absorption: The ratio of absorbed solar radiation to incident solar radiation.

Solar control film: Plastic films, coated with a metallic reflective surface, that are adhered to window glass to reflect solar heat gain. See also window film.

Solar gain: Heat from the sun that is absorbed by a building's materials and contributes to the heating and cooling requirements of the dwelling.

Solar heat: Radiant energy from the sun with wavelengths between 0.7 and 1 micrometers.

Solar heat gain coefficient (SHGC): The ratio of solar heat gain through a window to incident solar heat, including both transmitted heat and absorbed/radiated heat.

Solar reflectance: The ratio of reflected solar radiation to incident solar radiation. See also albedo.

Solar screen: A framed screen, installed on the window's exterior, designed to absorb solar heat before it strikes window glass.

Solar transmittance: The percent of total solar energy transmitted by a transparent or translucent material.

Solar water heater: Water-heating system where solar radiation heats the water.

Solenoid: An electromagnetic device that moves a switch or valve stem.

Sone level: An international unit used to measure sound levels. One sone is equivalent to the sound of a quiet refrigerator in a quiet kitchen.

Space conditioning: Heating, cooling, or ventilation of an indoor space.

Space heating: Heating of the building's living spaces with a room heater or central heating system.

Spalling: Surface degradation of masonry materials because of moisture movement.

Span: Horizontal distance between supports.

Specific heat: The ratio of the heat storage capacity of a particular material to the heat storage capacity of water.

Spillage: Temporary flow of combustion gases from a *dilution device*.

Spline: A strip of vinyl, rubber, or plastic that, when inserted into a groove, holds a screen or plastic film in place on a frame.

Split-system air conditioner: An air conditioner having the condenser and compressor outdoors and the evaporator indoors.

Spray foam: Liquid-applied foam that expands forming a rigid foam material with millions of insulating cells.

Spot ventilation: Spot ventilation includes kitchen exhaust fans and bathroom exhaust fans. See also *local ventilation*.

Stack effect: The draft established in a building from outdoor air infiltrating low and exfiltrating high.

Standard Work Specifications: Voluntary guidelines for quality work for residential energy upgrades. These specifications define the minimum requirements for high-quality installation of energy-conservation measures.

Standing loss: Heat loss from a hot water storage tank through its shell.

State point: Air at a particular temperature and humidity occupies a single point on the psychrometric chart called a state point.

Static pressure: Measurement of pressure in a fluid filled chamber at a specific location, and at a right angle to the fluid flow.

Steady-state efficiency (SSE): The heating-efficiency percentage calculated by a combustion analyzer by measurements of oxygen and flue-gas temperature.

Steel chassis: Supporting under-frame for the mobile home.

Steam trap: An automatic valve that closes to trap steam in a radiator until it condenses.

Steam vent: A bimetal-operated air vent that allows air to leave steam piping and radiators, but closes when steam arrives at the vent.

Stiles: Full-length vertical framing members of a door.

Stop: A thin, trim board for windows and doors to close against or slide against.

Strapping: Similar to furring. A nailer applied to a building surface.

Strike plate: The metal plate attached to the door jamb that the latch inserts into upon closing.

Strip heat: An electric-resistance heating cable or element as in a heat pump for electric resistance heater.

Stucco: Plaster applied to the building's exterior walls.

Stud: A vertical wood or metal framing member used to build a wall.

Subfloor: The sheathing over the floor joists and under the floor covering.

Subspace: A space or zone located partially or completely below grade, such as a basement or crawl space.

Subcooling: The number of degrees Fahrenheit that a condenser and nearby piping cools the liquid refrigerant below its saturation temperature.

Subgrantee: An agency—usually a community action agency—that is awarded a sub-grant and is accountable to the grantee (State government) for managing weatherization at a local level.

Substrate: A layer of material to which another layer is applied.

Sulfur dioxide (SO₂): A colorless, nonflammable, water-soluble gas air pollutant.

Sump pump: A pump that removes water from underneath a building.

Superheat: The number of degrees Fahrenheit that an evaporator and nearby piping heats gaseous refrigerant above its saturation temperature.

Supply air: Heated or cooled air that moves out of an *air handler* through the ducts and to the *supply registers* of a building.

Suspended ceiling: Modular ceiling panels supported by a hanging frame.

Tankless water heater: A water heater with no storage tank that heats water instantaneously as the water flows through it. Also called: *instantaneous water heater*.

Task lighting: Lighting provided at the area where a visual task is performed.

Temperature: A measure of the heat present.

Temperature and pressure relief valve: A safety component required on boilers and water heaters, designed to relieve excess pressure or temperature in the tank by discharging water.

Temperature rise: The number of degrees of temperature that the heating fluid increases as it moves through the heat exchanger.

Therm: A unit of energy equal to 100,000 Btus or 29.3 kilowatt-hours.

Thermal barrier: A material that protects materials behind it from flame impingement or from reaching 250° F during a fire. Drywall is a 15-minute thermal barrier.

Thermal boundary: A line or plane where insulation and air barrier(s) exist in order to resist thermal transmission and air leakage through or within a building shell.

Thermal break: A relatively poor heat-conducting material separating two highly conductive materials, installed to reduce heat flow through the assembly.

Thermal bridging: Rapid heat conduction resulting from direct contact between very thermally conductive materials like metal and glass.

Thermal bypass: A large air leak that allows air to flow around insulation.

Thermal conductance: A homogeneous material's ability to conduct heat, denoted by the letter k .

Thermal emittance: Thermal emittance or thermal emissivity is the ratio of the radiant emittance of heat of a specific object or surface to that of a standard object called a black body.

Thermal enclosure/envelope: The insulated and air-sealed boundaries of a dwelling that surround the conditioned space.

Thermal mass: A solid or liquid material that absorbs and stores heating or cooling energy until it is needed.

Thermal resistance: R-value; a measurement expressing the ability to resist heat flow.

Thermal transmittance: Expressed as U-factor, thermal transmittance is heat flow by conduction, convection, and radiation through a layered building component like a wall.

Thermistor: An electronic resistor used to sense temperature.

Thermocouple: A bimetal-junction electric generator used to keep the safety valve of an automatic gas valve open.

Thermodynamics: The science of heat.

Thermostat: A device used to control a heating or cooling system to maintain a *setpoint* temperature.

Threshold: The raised part of a floor underneath a door that acts as an air and dust seal.

Ton of refrigeration: The capacity to remove 12,000 BTUs per hour of heat from a building.

Total solar energy rejected: The percent of incident solar energy rejected by a glazing system equals solar reflectance plus the part of solar absorption that is reradiated outward.

Tracer gas: A harmless gas used to measure air leakage in a building.

Training and technical assistance (T&TA): Formal technical communication that ensures that all work in the field meets State standards.

Transformer: A double coil of wire that increases or decreases voltage from a primary circuit to a secondary circuit.

Trim: Decorative wood that covers cracks around window and door openings and at the corners where walls meet floors and ceilings. Sometimes called molding.

Truss: A braced framework usually in the shape of a triangle to form and support a roof.

Tuck-under garage: Architectural style in which the garage is situated underneath a room of the house.

Turbine vent: Vent usually mounted on the roof of a building. The vent has at its head a globular, vaned rotor that is rotated by wind, conveying air through a duct to and from a chamber below.

Two-part foam: A triple-expanding foam that insulates and seals air leaks. Two-part foam comes in portable low-pressure two-tank kits and high-pressure truck-mounted spray systems.

Type IC recessed electrical fixture: An recessed light fixture that is rated to be in direct contact with fibrous insulation.

Type-S fuses: Fuse type with a rejection base that prevents tampering as well as mismatching.

U-factor: The total heat transmission of a building assembly in BTUs per square feet per hour per degree Fahrenheit between the indoor and the outdoors.

U.S. Department of Agriculture (USDA): United States government agency responsible for agricultural programs, USDA also administers some housing programs.

U.S. Department of Energy (DOE): United States government agency whose mission is to advance energy technology and promote related innovation in the United States.

U.S. Department of Housing and Urban Development (HUD): United States government agency charged with rule-making and enforcement of the HUD Code for manufactured homes.

U.S. Environmental Protection Agency (EPA): The mission of the U.S. Environmental Protection Agency is to protect human health and the environment.

U-value: See U-factor. An older term for *U-factor*.

Ultraviolet Radiation: Light radiation having wavelengths beyond the violet end of the visible spectrum; high frequency light waves.

Unconditioned crawl space: A crawl space without a supply of heat from a forced-air register or other heat emitter.

Unconditioned space: An area within the building envelope not intentionally heated.

Underlayment : Sheetting installed to provide a smooth, sound base for a finish material.

Under-fired: Describes a burner that isn't receiving a sufficient flow rate of fuel.

Underwriter's Laboratory (UL): A private laboratory that tests materials and lists their fire-resistance characteristics.

Uniform Mechanical Code (UMC): A model code developed by the International Association of Plumbing and Mechanical Offi-

cial to govern the installation and inspection of mechanical systems.

Uniform Plumbing Code (UPC): A model code developed by the International Association of Plumbing and Mechanical Officials to govern the installation and inspection of plumbing systems.

Unintentionally conditioned: A space that is heated or cooled by energy that escapes the heating or cooling system. For example: a cooled attic or heated crawl space, which have no intentional space conditioning or comfort needs.

Unitary: Refers to an HVAC system that has all its components in one cabinet. See also: Packaged

Unvented attic: An attic space without intentional vents to ventilate it.

Upduct: An automatic vent, between the conditioned space and the attic, that operates by the pressure created by an evaporative cooler. Upducts exhaust room air into the attic. Used when open windows are a security problem.

Upflow furnace: A furnace in which the heated air flows upward as it leaves the furnace.

Upstream: Toward the source of the flow.

Vapor barrier: A material that controls water-vapor *diffusion* to less than 0.1 perms.

Vapor diffusion: The flow of water vapor through a solid material.

Vapor permeable: A material with a water vapor *permeance* of more than 10 perms.

Vapor pressure: The pressure exerted by a vapor, which increases with temperature.

Vapor retarder: A material that limits water-vapor diffusion to less than 10 perms.

Vaporize: To change from a liquid to a gas.

Vaulted attic/ceiling: An attic bounded by a sloped ceiling and sloped roof, which is created by a roof truss and typically has more than 16 inches of space between the ceiling and roof.

Veiling reflection: Light reflection from an object or task that obscures visibility.

Veneer: The outer layer of a building component that protects or beautifies the component.

Vent connector: The vent pipe carrying combustion gases from the appliance to a vent or chimney.

Vent chute: A lightweight plate that directs air from a soffit over attic insulation and along the bottom of the roof deck to ventilate the attic and cool the roof deck. A *baffle*.

Vent damper: An automatic damper powered by heat or electricity that closes the chimney while a heating device is off.

Vent pipe: The pipe carrying combustion gases from the appliance to the chimney.

Vent terminations: A fitting that prevents moisture intrusion, detritus, or pests into the building, and allows safe exhaust of vented gases.

Vented crawl space: Crawl space with grilles or vents installed to allow for passive ventilation beneath the home.

Venting: The removal of combustion gases by a chimney or horizontal vent.

Venting system: A continuous passageway from a combustion appliance to the outdoors through which combustion gases can safely pass.

Ventilation: Refers to the controlled air exchange within a structure such as local ventilation, whole-house ventilation, attic ventilation, and crawl space ventilation.

Vermiculite: A heat-expanded fire-resistant mineral used for insulation.

Visible transmittance: The percent of visible light transmitted by a glass assembly.

Visqueen: Polyethylene film vapor barrier.

Volt: The amount of electromotive force required to push a current of one ampere through a resistance of one ohm.

Voltage drop: The reduction of voltage in a circuit caused by resistance.

Volume: The amount of space occupied by a three-dimensional object or region of space, expressed in cubic units.

Water-resistive barrier: A water-resistant material used to prevent water from wetting a building's structural sheathing and other vulnerable components.

Watt (W): A unit of measure of electric power at a point in time, as capacity or demand. One Watt of power is equal to one *joule* per second.

Watt-hour: One Watt of power used continuously for one hour. One thousandth of a kilowatt-hour.

Watt meter: An instrument for measuring watts of electric power in a circuit.

Weatherization: The process of reducing energy consumption and increasing comfort in buildings by improving the energy efficiency of the building while maintaining health and safety.

Weatherization Assistance Program (WAP): DOE's Weatherization program.

Weatherization program notices (WPN): Guidance documents issued by the U.S. Department of Energy for the weatherization program.

Weather-resistant barrier: See *water-resistive barrier*.

Weatherstripping: Flexible *gaskets*, often mounted in rigid metal strips, for limiting air leakage at openings in the building envelope such as doors and windows.

Webbing: A reinforcing fabric used with mastics and coatings to prevent the coating from cracking.

Weep holes: Holes drilled for the purpose of allowing water to drain out of an area in a building where it accumulates.

Wet-bulb temperature: The temperature of a dampened thermometer of a sling psychrometer used to determine relative humidity, dew point, and enthalpy.

Wet spray: Fibrous insulation mixed with water and sometimes also a binder during installation.

Whole-house fan: A fan that draws fresh outside air into the living space, flushes hot air up the attic and exhausts it to the outside.

Whole-building ventilation: Controlled air exchange using one or more fans and ducts to maintain good indoor air quality and to keep the building sufficiently dry.

Wind effect: Building pressure and airflow between indoor and outdoors caused by the wind.

Wind washing: Wind-driven air passing over and through building materials, particularly insulation.

Window films: Plastic films coated with a metallic reflective surface that adhere to window glass in order to reflect solar radiation.

Window frame: The sides, top, and sill of the window forming a box around window sashes and other components.

With reference to (WRT): Compared to another measurement. In weatherization, a way to assess pressure differences between ducts and the rest of the home.

Work order: An order authorizing workers to complete specified tasks. Sometimes called the work scope.

Workforce Guidelines: DOE guidance on specific energy conservation measures; also called *Standardized Work Specifications*.

Work scope: The summary of energy conservation measures, materials lists and labor estimates that is prepared by an energy auditor as part of an energy audit. Same as: work order.

Worst-case depressurization test: A safety test, performed by specific procedures, designed to evaluate the probability of chimney back-drafting.

Zone: A room or portion of a building separated from other rooms by an air barrier.

Zone pressure diagnostics (ZPD): Using a blower door to determine the interconnectivity of various building components, which helps the practitioner locate the air barrier and know if the insulation and air barrier are aligned. Also called zonal pressure diagnostics.

Searching Field Guide Topics

The Indiana Field Guide document contains *numerous* references to the various topics throughout the guide. To search for a specific topic or word; AND in order to locate ALL references to that word or topic, the best method is to utilize the search function. The search function can be utilized when the document is in WORD or PDF format.

To search: Use the function Ctrl + F.

Press the "Ctrl" key on your keyboard and then press the letter "F". Once you have pressed these two keys, a search box will appear on your screen. You can then enter the word(s)/topic in the search box. Once that is complete, press "Enter". The number of occurrences will be denoted and then you can quickly scroll through the Field Guide to find *all* occurrences of the searched term and you will not miss important information to your topic.

The Indiana Weatherization Field Guide outlines procedures for improving the comfort, durability, and energy efficiency of existing homes.

- ➔ Health and Safety
- ➔ Energy Audits and Quality Control Inspections
- ➔ Weatherization Materials
- ➔ Attics and Roofs
- ➔ Walls
- ➔ Floors and Foundations
- ➔ Windows and Doors
- ➔ Heating and Cooling Systems
- ➔ Ventilation
- ➔ Baseload Measures
- ➔ Mobile Homes
- ➔ Air Leakage Diagnostics



Reprinted with permission from



SATURN
RESOURCE MANAGEMENT
www.srmi.biz

Version: 040918